



## Completion of the Custom Wiring Harness Worksheet

The second page of this document is the wire harness worksheet that must be completed and FAXed back to PS Engineering, Inc. Upon the receipt of the worksheet, PS Engineering, Inc. will debit the credit card for the entire amount of the harness plus any other additional hardware or shipping charges that are indicated on the wire harness worksheet.

Wire Harnesses are not **cancelable** or **returnable**.

Allow five-business days from our receipt of your harness worksheet to the time the harness is shipped.

The best technique to measure the needed cable lengths is to take a piece of string, and run it from the desired unit location to the desired jack location, next to, or through the aircraft structure along the planned cable route. Then measure that string to determine the wire run. Repeat for each individual run (pilot jacks, passenger jacks, music jacks etc.).

Enter the length in the "Length (feet)" column. If the length is longer than the basic length included in the base price, there will be an extra per-foot cost. (No, you won't get credit if the length is LESS than the base cost). If any of the column boxes are empty, then PS Engineering will assume that wire connection is not required or needed.

The harness we make will include the top PMA6000 connector that contains all of the intercom functions. The harness we provide will NOT include any radio interface, which is on the bottom connector. It is the installers' responsibility to make the radio interface. Consult your PS Engineering dealer for assistance.

The "Swap" (S) mode allows the pilot to switch from COM 1 to COM 2, and back, using a remote momentary switch (switch not included).

There are two music inputs in the PMA6000. Music 1 goes to all headsets in ALL intercom mode. Music 1 goes to the pilot and copilot headsets, *in crew mode*, while Music 2 goes to the passengers' headsets *only*. We will put 1/8" stereo jacks on these inputs. To control the Entertainment muting, a switch (not included) is connected across the Mute control (SM) lines.

Resist the temptation to use the lengths listed on the worksheet. These are listed not because they are any type of standard lengths, but rather, provides PS Engineering, Inc a basis for the cost of the harness.

Ordering a harness with excessive wire lengths will increase the likelihood of Radio Frequency Interference (RFI). The only alternative to a too long a wire run is to cut it to length. However, this eliminates the work that had already been done in prepping the wires and will require special tools to re-prepare the wires for termination to the mic and headphone jacks.

Passenger *headphone* jacks are "daisy-chained." That means that a single cable will connect the unit to the first set of passenger jacks (L1). From there, another wire will go the next set of passenger jacks (HC), and then to the last set of jacks (H3 and H4). All microphone connections are separate cables from the unit to the mic jacks (M2, 3 etc.).

We typically do not install intercom headphone jacks on the harness unless specifically requested. It is usually easier to feed the wires through the airplane without the jacks attached to the harness. However, if you elect to have us install jacks to your harness we will be glad to do so. The cost is \$8.75 for each set of headphone and microphone jacks.

Power and ground wires will be the length you specify. The lengths should include the distance from the circuit breaker on the avionics bus (power) and the ground location (ground) to the PMA6000. In 14-volt aircraft,

We do not provide wires for interface to the aircraft radio. These wires are all interfaced with the bottom connector, with crimp and insert pins. Consult the radio manufacturer's installation manual for connection information, and contact your PS Engineering dealer for help if needed.

A hardcopy order sheet is required, no phone orders accepted. Scanned sheets can be emailed to [harnesses@ps-engineering.com](mailto:harnesses@ps-engineering.com).

**PS ENGINEERING, INC. → 9800 MARTEL ROAD, LENOIR CITY TN 37772  
(865) 988-9800 PHONE → (865) 988-6619 FAX**

**PMA6000 (MONO) HARNESS ORDER SHEET**

**HARNESS IS NON CANCELLABLE AND NON RETURNABLE**

NAME: \_\_\_\_\_ DATE: \_\_\_\_\_  
 ADDRESS: \_\_\_\_\_ PHONE: \_\_\_\_\_  
 \_\_\_\_\_ Ship Method: \_\_\_\_\_  
 City: \_\_\_\_\_ State: \_\_\_\_\_  
 Zip/Post Code: \_\_\_\_\_  
 Visa/MC#: \_\_\_\_\_ Expiration: \_\_\_\_\_  
 Aircraft Make & Model: \_\_\_\_\_

| Designation | Location                                      | Length (feet) | Excess Length                  |
|-------------|---|---------------|--------------------------------|
| E1          | PMA6000 to Crew Music Jack (#1)               |               | Additional cost if over 3 ft.  |
| E2          | PMA6000 to Passenger Music Jack (#2)          |               | Additional cost if over 3 ft.  |
| SM          | PMA6000 to Mute Control (switch not incl.)    |               | Additional cost if over 10 ft  |
| S           | PMA6000 to COM Swap switch (switch not incl.) |               | Additional cost if over 3 ft   |
| LP          | PMA6000 to Pilot Mic and Headphone Jacks      |               | Additional cost if over 3 ft.  |
| LC          | PMA6000 to Copilot Mic and Headphone Jacks    |               | Additional cost if over 4 ft.  |
| L1          | PMA6000 to Pass 1 Mic and Headphone jacks     |               | Additional cost if over 12 ft. |
| M2          | PMA6000 to Passenger 2 Microphone Jacks       |               | Additional cost if over 10 ft. |
| M3          | PMA6000 to Passenger 3 Microphone Jacks       |               | Additional cost if over 10 ft  |
| M4          | PMA6000 to Passenger 4 Microphone Jacks       |               | Additional cost if over 10 ft  |
| HC          | Pass 1 headphone to Passenger 2 Headphone     |               | Additional cost if over 12 ft. |
| H3          | Pass 1 headphone to Passenger 3 Headphone     |               | Additional cost if over 10 ft  |
| H4          | Pass 2 headphone to Passenger 4 Headphone     |               | Additional cost if over 10 ft  |
| PG          | PMA6000 to aircraft ground and power          |               | Additional cost if over 10 ft  |

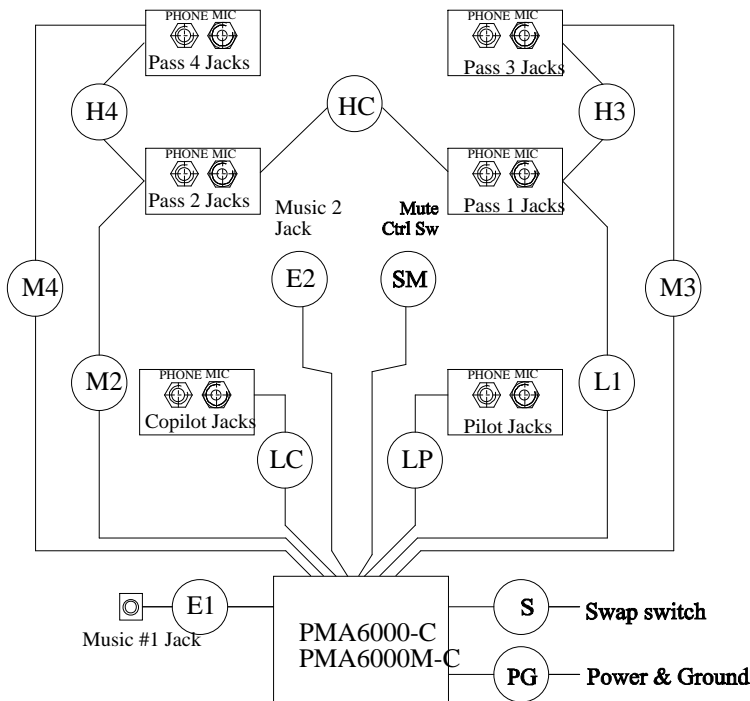

**Harness Part Number  
 15604 (6-place)**

**Notes:**

Each harness is professionally manufactured using Mil-Spec, Tefzel<sup>®</sup> shielded cable, and is clearly marked for easy identification using heat shrink labeling.

Turn-around time is 5-business days from receipt of completed worksheet, or shipping is free.

**RADIO INTERFACE NOT INCLUDED**

**Jacks are not included.**

Please specify if mic and headphone jacks are to be added.

Special Instructions: \_\_\_\_\_

\_\_\_\_\_  
 \_\_\_\_\_  
 \_\_\_\_\_  
 \_\_\_\_\_

CALL or FAX FOR PRICING: \_\_\_\_\_

DOC 15604-031710