



Completion of the Custom Wiring Harness Worksheet

The second page of this document is the wire harness worksheet that must be completed and returned to PS Engineering, Inc. Upon the receipt of the worksheet, PS Engineering, Inc. will debit the credit card for the entire amount of the harness plus any other additional hardware or shipping charges that are indicated on the wire harness worksheet.

Wire Harnesses are not **cancelable** or **returnable**.

Allow five-business days from our receipt of your harness worksheet to the time the harness is shipped.

The best technique to measure the needed cable lengths is to take a piece of string, and run it from the desired unit location to the desired jack location, next to, or through the aircraft structure along the planned cable route. Then measure that string to determine the wire run. Repeat for each individual run (pilot jacks, passenger jacks, music jacks etc.).

Enter the length in the "Length (feet)" column. If any of the column boxes are empty, then PS Engineering will assume that wire connection is not required or needed.

The base price is the cost of building the basic harness with minimum required connections, while the per-foot cost is the cost of the wire to the termination. For instance, the pilot headphone will cost \$27.50 for a 10-foot cable run ($\$2.75 \times 10'$). If your installation does *not* have certain radios or connections, you will not be charged a foot price. Total the far right column to determine the harness price.

Specify number of unswitched audio sources, up to 4. These can include ADF, DME, Marker audio, Alert audio, etc.

The optional (p/n 11941 only) internal recording system can be played back using a remote momentary switch (PB) (switch not included).

Ordering a harness with excessive wire lengths will increase the likelihood of Radio Frequency Interference (RFI). The only alternative to a too long a wire run is to cut it to length. However, this eliminates the work that had already been done in prepping the wires and will require special tools to re-prepare the wires for termination to the mic and headphone jacks.

Passenger *headphone* jacks are "daisy-chained." That means that a single cable will connect the unit to the first set of passenger jacks (L1). From there, another wire will go the next set of passenger jacks (H12). All microphone connections are separate cables from the unit to the mic jacks (M2, 3 etc.).

We typically do not install intercom headphone jacks on the harness unless specifically requested. It is usually easier to feed the wires through the airplane without the jacks attached to the harness. However, if you elect to have us install jacks to your harness we will be glad to do so. The cost is \$8.75 for each set of headphone and microphone jacks.

Power and ground wires will be the length you specify. The lengths should include the distance from the circuit breaker on the avionics bus (power) and the ground location (ground) to the PMA4000.

We provide a specified length of wires for interface to the aircraft radio. These wires are stripped and timed, and ready to have the corresponding radio connector pins installed. Consult the radio manufacturer's installation manual for connection information, and contact your PS Engineering dealer for help if needed.

A hardcopy order sheet is required, no phone orders accepted. Scanned sheets can be emailed to harnesses@ps-engineering.com.

PMA4000 HARNESS ORDER SHEET

HARNESS IS NON CANCELLABLE AND NON RETURNABLE

NAME: _____ DATE: _____
 ADDRESS: _____ PHONE: _____
 _____ Ship Method: _____
 City: _____ State: _____
 Zip/Post Code: _____
 Visa/MC#: _____ Expiration: _____
 Aircraft Make & Model: _____

Designation	Location	Length (feet)	Base Price: Price per foot	\$258.90 Subtotal = (per foot x length)
E1	PMA4000 to Music Jack		\$ 1.15	
LP	PMA4000 to Pilot Jacks		\$ 2.75	
LC	PMA4000 to Copilot Jacks		\$ 2.75	
L1 (if more than 2-place)	PMA4000 to Passenger 1 Jacks		\$ 2.75	
H12 (if more than 2-place)	Passenger 1 Phones to Passenger 2 Phones		\$ 1.15	
M2 (if more than 2-place)	PMA4000 to Passenger 2 Mic		\$ 1.15	
RV (optional)	PMA4000 to remote Volume/Expansion unit		\$ 1.50	
NC1	PMA4000 to Nav/Com 1		\$2.75	
	Com 1 Phones & Microphone			
NC2	Nav 1 (if present)		\$ 1.15	
	PMA4000 to Nav/Com 2		\$ 2.75	
	Com 2 Phones & Microphone		\$ 1.15	
US	PMA4000 to unswitched receivers			
	PMA4000 to Unswitched Receiver #1		\$ 1.15	
	PMA4000 to Unswitched Receiver #2		\$ 1.15	
	PMA4000 to Unswitched Receiver #3		\$ 1.15	
PB	Optional IRS Playback (11941 only)		\$0.20	
SP	PMA4000 to Cockpit Speaker		\$1.15	
PG	Power and Ground		\$ 0.20	
	Phone and Mic jack sets added to the harness	#	\$8.75 x of sets	
Total				

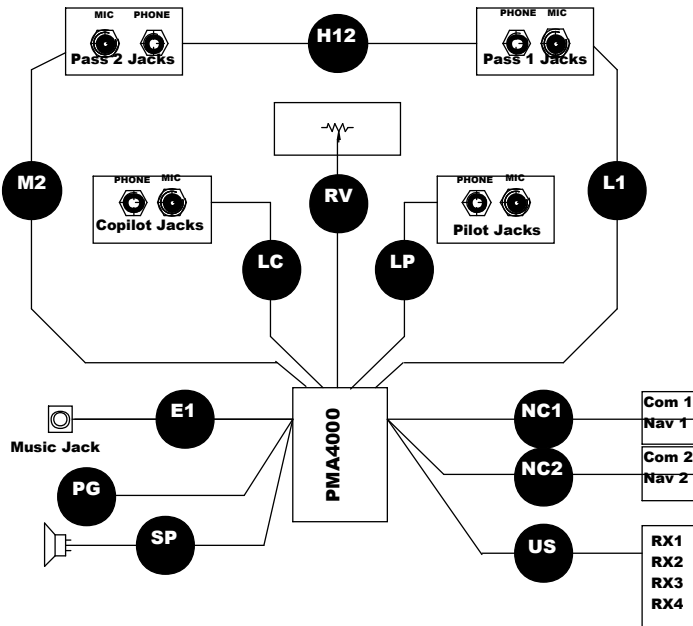

Notes:
 Each harness is professionally manufactured using Mil-Spec, Tefzel® shielded cable, and is clearly marked for easy identification using heat shrink labeling. Turn-around time is 5-business days from receipt of completed worksheet, or shipping is free. Jacks are not included. Please add \$8.75 per set of mic and headphone jacks. Special Instructions: _____

