



9800 Martel Road

Lenoir City, TN 37772

www.ps-engineering.com

PMA8000-SR



Audio Selector Panel with Marker Beacon Receiver
High-fidelity Stereo Intercom with integrated SIRIUS Satellite Radio
System Installation and Operation Manual
FAA-Approved TSO C50c, C35d
Patented under one or more of the following;
No. 5,903,227; 6,160,496 and 6,493,450

Document P/N 200-880-0000

Revision 15, June 2009

**In certified aircraft, warranty is not valid unless this product is installed by an
Authorized PS Engineering dealer.**

PS Engineering, Inc. 2009 ©

Copyright Notice

Any reproduction or retransmittal of this publication, or any portion thereof, without the expressed written permission of PS Engineering, Inc. is strictly prohibited. For further information contact the Publications Manager at PS Engineering, Inc., 9800 Martel Road, Lenoir City, TN 37772. Phone (865) 988-9800, email contact@ps-engineering.com.

Table of Contents

SECTION I GENERAL INFORMATION	1-1
1.1 INTRODUCTION	1-1
1.2 SCOPE.....	1-1
1.3 EQUIPMENT DESCRIPTION	1-1
1.4 APPROVAL BASIS –	1-2
1.5 SPECIFICATIONS	1-2
1.6 EQUIPMENT SUPPLIED	1-4
1.7 EQUIPMENT REQUIRED BUT NOT SUPPLIED	1-4
1.8 REQUIRED TEST EQUIPMENT TO CHECK INSTALLATION.....	1-4
1.9 LICENSE REQUIREMENTS.....	1-4
1.8 SIRIUS SUBSCRIPTION REQUIREMENTS.....	1-4
SECTION II - INSTALLATION	2-1
2.1 GENERAL INFORMATION	2-1
2.1.1 SCOPE.....	2-1
2.1.2 CERTIFICATION REQUIREMENTS	2-1
2.2 UNPACKING AND PRELIMINARY INSPECTION	2-1
2.3 EQUIPMENT INSTALLATION PROCEDURES	2-1
2.3.1 COOLING REQUIREMENTS.....	2-1
2.3.2 MOUNTING REQUIREMENTS.....	2-1
2.3.3 AUDIO PANEL MOUNTING RACK INSTALLATION	2-2
2.3.4 AUDIO PANEL TRAY AND CONNECTOR ASSEMBLY	2-2
2.4 CABLE HARNESS WIRING.....	2-2
2.4.1 NOISE	2-2
2.4.2 EXISTING GMA340 INSTALLATION	2-3
2.4.3 POWER.....	2-3
2.4.4 COMMUNICATIONS PUSH-TO-TALK	2-3
2.4.5 AUDIO PANEL INTERFACE.....	2-3
2.4.6 TEL (DUPLEX) FUNCTION FOR CELL PHONES	2-4
2.4.7 TRANSMIT INTERLOCK.....	2-4
2.4.8 PATENTED "SWAP" MODE	2-4
2.4.9 BACKLIGHTING.....	2-4
2.4.10 UNSWITCHED INPUTS.....	2-5
2.4.11 PUBLIC ADDRESS MODE.....	2-5
2.4.12 PA MUTE (J2, PIN 12)	2-5
2.4.13 MISCELLANEOUS LOGIC OUTPUT (J2, PIN 18).....	2-5
2.4.14 INTERCOM WIRING.....	2-6
2.4.15 SIRIUS SATELLITE RADIO INSTALLATION	2-6
2.4.16 SIRIUS SATELLITE RADIO FUNCTIONS	2-6
2.4.17 USE OF PXE7300 AND PAV 80 AUX INPUTS FOR SIRIUS SATELLITE RADIO DISTRIBUTION	2-8
2.4.18 ENTERTAINMENT MUTING	2-9
2.4.19 PLAYBACK BUTTON INSTALLATION (J2, PIN 22- OPTION 1, ONLY).....	2-10
2.5 MARKER BEACON INSTALLATION.....	2-10
2.5.1 MARKER ANTENNA INSTALLATION	2-10
2.5.2 EXTERNAL MARKER LIGHTS	2-10
2.5.3 MIDDLE MARKER SENSE (MARKER VERSION).....	2-10
2.6 ADJUSTMENTS.....	2-10
2.7 COMMUNICATIONS ANTENNA INSTALLATION NOTES.....	2-11
2.7.1 AUDIO ACTIVE OUTPUT.....	2-11
2.8 PMA8000-SR PIN ASSIGNMENTS.....	2-12
2.9 POST INSTALLATION CHECKOUT	2-13
2.9.1 REQUIRED TEST EQUIPMENT	2-13
2.10 UNIT INSTALLATION	2-13
2.10.1 OPERATIONAL CHECKOUT.....	2-13

PS Engineering
PMA8000-SR Series Audio Selector Panel and Intercom System
Installation and Operator's Manual

2.11 TEL CHECKOUT 2-14

2.12 SIRIUS SATELLITE RADIO CHECKOUT 2-14

2.12.1 SIRIUS SIGNAL DROPOUT 2-14

2.12.2 SIRIUS SATELLITE RADIO ID NUMBER 2-15

2.13 INTERNAL RECORDER CHECKOUT (OPTIONAL)..... 2-15

2.14 FINAL INSPECTION..... 2-15

SECTION III OPERATION 3-1

3.1 SCOPE..... 3-1

3.2 POWER SWITCH (1) (EMG-FAIL SAFE OPERATION)..... 3-1

3.3 MICROPHONE (2) (XMT) SELECTION (ALL MODELS)..... 3-1

3.3.1 SWAP MODE (SWITCH FROM COM 1 TO COM 2 REMOTELY)..... 3-2

3.4 AUDIO SELECTOR (4)..... 3-2

3.4.1 SPEAKER AMPLIFIER (5) 3-2

3.5 SPLIT MODE 3-3

3.5.1 MUTE BUTTON, SPLIT MODE ICS (6) 3-3

3.6 INTERCOM OPERATION 3-3

3.6.1 *INTELLIVox*® VOX-SQUELCH 3-3

3.6.2 INTERCOM VOLUME CONTROL (7)..... 3-4

3.6.3 INTERCOM MODES (8) 3-4

3.7 TELEPHONE MODE (9)..... 3-6

3.8 SIRIUS SATELLITE RADIO OPERATION (10) 3-6

3.8.1 SIRIUS SIGNAL DROPOUT..... 3-7

3.8.2 FRONT PANEL CONTROL OF SIRIUS RADIO 3-7

3.9 MARKER BEACON OPERATION (10)..... 3-8

3.10 INTERNAL RECORDER SYSTEM (OPTION 1)..... 3-8

3.11 OPERATION 3-8

SECTION IV- WARRANTY AND SERVICE 4-1

4.1 WARRANTY 4-1

4.2 FACTORY SERVICE..... 4-1

APPENDIX A EXTERNAL PTT HOOK UP..... A

APPENDIX B – PMA 8000 INSTALLATION DRAWINGS..... B

APPENDIX C, J1 INTERCONNECT C

APPENDIX D, J2 CONNECTOR INTERCONNECT D

APPENDIX E- INSTRUCTIONS FOR FAA FORM 337 AND CONTINUING

AIRWORTHINESS E

9.1 INSTRUCTIONS FOR FAA FORM 337, AUDIO PANELS..... E

9.2 INSTRUCTIONS FOR CONTINUING AIRWORTHINESS, AUDIO SYSTEM..... E

APPENDIX F RTCA DO160D ENVIRONMENTAL QUALIFICATION FORM F

Rev	Date	Change
3	3/9/05	RF connector detail added/TSO Approved
4	3/18/05	Added PA Mute Enable description and alt music, clarified SIRIUS Satellite Radio warranty
5	3/24/05	Combined installation parts kits and updated kit numbers
6	5/18/05	Corrected antenna connector reference
7	5/24/05	Corrected text for Unswitched Audio distribution 2.4.10
8	6/22/05	Added note for AUX and logic switching if DME installed
9	7/26/05	Added Ent. 1 low that could be needed if an external input is used. Corrected 3.7
10	8/1/05	Clarified Section 2.4.16.4 to REMOVE jumpers if necessary.
11	11/17/05	Added note for "TX Mute" J2 pin 30, Sect. 2.4.2.1, 2.4.16 & Appendix D
12	03/29/06	Added information on using PXE7300 and PAV80 AUX interface, Section 2.4.17
13	06/14/06	Added backshell retaining clamp to installation kit
14	10/6/08	Corrected PA indication in § 3.4.1.2
15	6/5/09	Added details on PA activation §2.4.11

Section I GENERAL INFORMATION

1.1 INTRODUCTION

The PMA8000-SR represents another evolutionary step in cockpit audio control and intercommunications utility. Using our patented *IntelliVox*® design, this unit eliminates the requirements for intercom squelch adjustments. The unit is designed for outstanding ergonomics and visually defined mode annunciation and selection.

Before installing and/or using this product, please read this manual completely. This will ensure that you will take full advantage of all the advanced features in the PMA8000-SR.

1.2 SCOPE

This manual provides detailed installation and operation instructions for the PS Engineering PMA8000-SR-series of Audio Selector Panel/Intercom Systems. This includes the following units:

<u>Model</u>	<u>Description</u>	<u>Part Number</u>
PMA8000-SR	Stereo Audio Selector Panel with Marker Beacon	050-880-0100
Option 1	Same as above with Digital Recorder added	050-880-0200

Where the functions are identical to all units, it will be referred to herein as a PMA8000-SR. Otherwise, the applicable units will be specified.

1.3 EQUIPMENT DESCRIPTION

The PMA8000-SR-series is a state of the art audio isolation amplifier and audio selector that contains an automatic voice activated (VOX) intercom system. It can switch two transceivers (Com 1, Com 2) and six receivers (Nav 1, Nav 2, ADF, DME, MKR and AUX).

A full duplex TEL mode allows the PMA8000-SR to act as an audio interface between aircraft headphone and microphones and specific aircraft approved (FAA/FCC) cellular telephone equipment.

Warning: Use of non-aviation approved cellular telephone equipment may be prohibited by regulation. PS Engineering is not responsible for unauthorized airborne use of cellular telephones. For airborne use, the PMA8000-SR must be interfaced with an approved system.

There are four unswitched inputs, available for traffic or EGPWS, autopilot disconnect, and/or radar altimeter warning.

Push buttons select the receiver audio source provided to the headphones. A SPR button allows the user to listen to the receiver(s) selected on the cabin speaker. Except for the unswitched inputs, all speaker audio is muted during transmit. Unswitched inputs are always presented to the aircraft speaker with the exception of #2 which is controlled by the speaker button.

Push button switches selects one of the communication transceivers for the pilot and copilot position, and allows radio transmission. In "Split Mode" the PMA8000-SR has the ability to allow the pilot to transmit on com 1 while the copilot can transmit on com 2. A fail-safe mode connects the pilot headphone and microphone to COM 1 if power is removed for any reason, or if the power switch is placed in the Off (Fail-safe) position.

A six-station voice activated (VOX) intercom is included in the PMA8000-SR. This system has PS Engineering's patented *IntelliVox*® circuitry that eliminates manual adjustments. The system contains six separate VOX mic circuits, and only opens the microphone channel in use.

The intercom system incorporates pilot isolate, all and crew modes, two independent stereo music inputs with "Soft Mute," and flashing LED indications for transmit indications. Intercom control is through two concentric front panel volume controls and a pushbutton intercom mode switch. The small volume knob

controls the intercom level for the pilot and copilot, while the large knob controls the passenger intercom volume. Intercom squelch is automatic.

The PMA8000-SR incorporates an integrated SIRIUS Satellite Radio receiver, which allows the aircraft occupants to enjoy their music

A 3-light Marker Beacon receiver is integrated in the PMA8000-SR. This provides the necessary Marker Beacon lights and audio indications necessary for an Instrument Landing System (ILS) approach. A pushbutton labeled MKR allows the pilot select high or low sensitivity as well as test and mute modes.

1.4 APPROVAL BASIS –

TSO Approval. C50c, C35d

The PMA8000-SR-series Audio Selector Panels are FAA approved under TSO C50c (Audio Amplifiers) and TSO C35d (Marker Beacon Receivers).

All systems comply with relevant portions of EUROCAE RTCA MPS WG No. 7/70, DO-143 and (*Marker Beacon Receivers*), ED-14C/DO-160C (*Environmental Conditions and Test Procedures for Airborne Equipment*), ED12B/DO-178B, Level D (*Software Considerations for Airborne Equipment*) and ED-18/DO-214 (*Audio Systems Characteristics and Minimum Operational Performance Standards for Aircraft Audio Systems*).

Operation is subject to the following conditions:

This device may not cause harmful interference.

This device must accept any interference received, including interference that may cause undesired operation.

1.5 SPECIFICATIONS

TSO COMPLIANCE	
<i>Marker Beacon:</i>	C35d, Class A
<i>Audio Selector/Intercom:</i>	C50c, Class A
APPLICABLE DOCUMENTS:	RTCA/DO-214 RTCA/DO-143 RTCA/DO-160D RTCA/DO-178B DO-254
ENVIRONMENTAL Qualifications:	A1D1CABSMXXXXXXZBABATBXXE2XXX
<i>Operating Temperature Range:</i>	-15° C to 55°C
<i>Altitude:</i>	Up to 50,000 feet in a non-pressurized area
DIMENSIONS:	Height: 1.3 in. (3.3 cm) Width: 6.25 in. (16.9 cm) Depth behind panel 8.25 in. (21.00 cm) including connectors
WEIGHT	
<i>PMA8000-SR Unit</i>	1.54 lb. (0.70 kg)
<i>Rack with connectors</i>	0.66 lb. (0.30 kg)
POWER REQUIREMENTS (Including Internal Lighting):	
<i>Voltage:</i>	11 to 33 VDC
<i>Maximum Current:</i>	3.0 Amp (Externally protected by a 5A pull-type breaker)

PS Engineering
PMA8000-SR Series Audio Selector Panel and Intercom System
Installation and Operator's Manual

Audio Selector Specifications	
<i>Audio selector panel input impedance:</i>	510 Ω
<i>Input Isolation:</i>	-60 dB (min.)
<i>Speaker Muting:</i>	-60 dB (min.)
<i>Speaker Output (into 4 Ω) with no clipping</i> 14 VDC: 28 VDC:	3 Watts (min.) 10 Watts (min.)
<i>Receiver Inputs:</i>	9 (Com 1, Com 2, TEL, Nav 1, Nav 2, ADF, DME, MKR, AUX)
<i>Unswitched Inputs:</i>	4
<i>Transmitter Selections:</i>	4 (Com 1, Com 2, TEL Com1/2)
<i>Speaker Impedance:</i>	4 Ω
<i>Headphone Impedance:</i>	150 – 1000 Ω
<i>Headphone Output:</i>	38 mW each headset, no clipping <1% THD typical
<i>Microphone Impedance:</i>	150 - 600 Ω
Intercom Specifications	
<i>Intercom Positions:</i>	6 places (with individual <i>IntelliVox</i> ® circuits)
<i>Music Inputs:</i>	2, (Independent, Stereo)
<i>Music Muting:</i>	>-30 dB "Soft Mute" when Com or intercom active.
<i>Distortion:</i>	<1% THD @ 38 mW into 150 Ω
<i>Mic Freq. Response, 3 dB:</i>	300 Hz - 6000 Hz
<i>Music Freq. Response, 3 dB:</i>	10 Hz – 26 kHz
MARKER BEACON RECEIVER:	
<i>Frequency:</i>	75 MHz Crystal Controlled
<i>Sensitivity:</i> Low: High:	Capable of: (preset at factory for field application) 1000 μ Volts (Hard) (360 to 570 μ V soft) 200 μ Volts (Hard) (130 to 200 μ V soft)
<i>Selectivity:</i>	-6 dB at \pm 10 kHz -40 dB at \pm 120 kHz
<i>External Lamp Output:</i>	7.5 (\pm 4 VDC unloaded, at maximum brightness) VDC positive when active, max. current 125 mA
<i>MM Sense:</i>	Active high (4.5 \pm 1.0VDC)

1.6 EQUIPMENT SUPPLIED

1 ea. of the following units:

Model	Description	Part Number
PMA8000-SR	PMA8000-SR Audio Panel with Marker Beacon and Stereo intercom.	050-880-0100
PMA8000-SR with option 1	Add Internal recorder to PMA8000-SR	050-880-0200

PMA8000 Installation Kit: 250-880-0000

Description	Quantity	Part Number
PMA8000-SR installation rack assembly	1	430-880-0040
PMA8000-SR Rack back plate assembly w/coax	1	010-880-1481
44-pin connector kit	2	120-891-2045-
Backshell, connector	2	625-025-2465
Backshell Retainer	2	431-881-0100
4 40 X 3/8 screw w/lock washer	4	475-440-1038
4 40 X 7/16 screw w/nylon patch	4	475-440-0007
4-40 Lock Nut	1	475-013-0001
Solder Lug	1	475-009-0001
Cable Clamp	1	625-001-0002
#6-32 x 1/2" Flat head Philips screw	6	475-632-0012
#6-32 Clip Nut	6	475-630-0002
SIRIUS Satellite Antenna w/ cable	1	510-880-0100
PMA8000-SR remote	1	050-803-0200

1.7 EQUIPMENT REQUIRED BUT NOT SUPPLIED

- a. Circuit Breaker: 1 ea; 5 amp PULL TYPE REQUIRED for PMA8000-SR
- a) Speaker, 4 Ω
- b) Headphone Jacks (Stereo, as Required)
- c) Microphone Jacks (as Required)
- d) Headphones, 150 Ω (Stereo), up to 6 as required
- e) Microphones, up to 6 as required
- f) Marker Antenna (75 MHz, VSWR <1:1.5, and appropriate for the airspeed)
- g) Interconnect Wiring

1.8 Required Test equipment to check installation

Marker Beacon signal generator, such as:

- a. IFR NAV401L, NAV402AP, IFR4000
- b. TIC T-30D, T-36C

1.9 LICENSE REQUIREMENTS

None

1.8 SIRIUS SUBSCRIPTION REQUIREMENTS

The Sirius Satellite Receiver requires an activation and periodic subscription. Monthly, annual and lifetime plans are available.

To activate the module, you will need to do the following:

- Locate the SID/ESN number from your SIRIUS receiver in the PMA8000-SR (found on the unit or played back, by pressing 4-1-1 with Sirius system turned on).
- A major credit card.
- The SIRIUS tuner installed, the aircraft outside with a clear view of the sky.
- Turn your SIRIUS tuner on and tune it to channel 184.

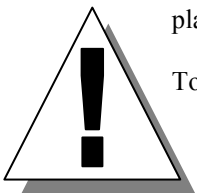

PS Engineering
PMA8000-SR Series Audio Selector Panel and Intercom System
Installation and Operator's Manual

When you activate online you pay only \$5.00 at www.sirius.com. If you choose to activate by phone the charge is \$15. You can either call 1.888.539.SIRIUS (7474) or activate online.

Keep in mind that there may be additional fees when you activate, based on the following criteria:

- \$5 charge to reactivate a receiver that has been inactive for over six months.
- \$5 late fee for monthly payments made after bill due date.
- Printed copies of account information less than 18 months old cost \$2.50 per request.
- Printed copies of account information more than 18 months old cost \$10 per request.
- Termination of service prior to the end of a prepaid subscription or committed subscription period will result in a \$75 cancellation fee. Fee does not apply for monthly plans.
- You are responsible for all taxes or other government fees and charges, if any, based on the address on your account.

NOTE: Prices subject to change without notice

Record your Radio ID here for future reference.

Press 4-1-1 on remote with SIRIUS Satellite Radio turned on to read back the SID.

Section II - Installation

2.1 GENERAL INFORMATION

2.1.1 SCOPE

This section provides detailed installation and interconnection instructions for the PS Engineering PMA8000-SR-Series Audio Selector Panel/Intercom/ with internal Marker Beacon.

Please read this manual carefully before beginning any installation to prevent damage and post-installation problems. Installation of this equipment requires special tools and knowledge.

2.1.2 Certification Requirements

NOTE

The PMA8000-SR requires specialized knowledge and tools for an effective installation. An appropriately rated Certified Aircraft Repair Station **must** install this equipment in accordance with applicable regulations. PS Engineering, Incorporated warranty is not valid unless the equipment is installed by an authorized PS Engineering, Incorporated dealer.

Failure to follow any of the installation instructions, or installation by a non-qualified individual or agency will void the warranty, may result in an **unairworthy** installation, and violate Federal Aviation regulations.

2.2 Unpacking and Preliminary Inspection

Use care when unpacking the equipment. Inspect the units and parts supplied for visible signs of shipping damage. Examine the unit for loose or broken buttons, bent knobs, etc. Verify the correct quantity of components supplied with the list in Section 1.6 (B). If any claim is to be made, save the shipping material and contact the freight carrier. Do NOT return units damaged in shipping to PS Engineering. If the unit or accessories show any sign of external shipping damage, contact PS Engineering to arrange for a replacement. Under no circumstances attempt to install a damaged unit in an aircraft. Equipment returned to PS Engineering for any other reason should be shipped in the original PS Engineering packaging, or other UPS approved packaging.

2.3 Equipment Installation Procedures

2.3.1 Cooling Requirements

Forced air-cooling of the PMA8000-SR is not required. However, the units should be kept away from heat producing sources (i.e. defrost or heater ducts, dropping resistors, heat producing avionics) without adequate cooling air provided.

2.3.2 Mounting Requirements

The PMA8000-SR must be rigidly mounted to the instrument panel of the aircraft structure and within view and reach of the pilot position(s). Installation must comply with FAA Advisory Circular AC 43.13-2A. The unit may be mounted in any area where adequate clearance for the unit and associated wiring bundle exist.

Avoid installing the unit close to high current devices or systems with high-voltage pulse type outputs, such as DME or transponders. Avoid running the interconnecting bundles near any high current wires.

2.3.3 Audio Panel Mounting Rack Installation

Remove the unit from the mounting tray by unscrewing the 3/32" hex-head screw that is in the center of the unit. Use caution to avoid hitting the photo-detector lens. Carefully slide the unit free of the tray. Set the unit aside in a safe location until needed. Install the tray using six clip nuts (475-630-0002), and six FHP 6-32 x 1/2" screws (475-632-0012). The audio selector panel must be supported at front and rear of the mounting tray.

2.3.4 Audio Panel Tray and Connector Assembly

The rack connectors mate with two 44-pin connectors in the PMA8000-SR. The connectors are a sub miniature crimp-type, and require the use a hand crimp tool, from table below (or equiv.). The connectors are mounted to the tray back plate with #4-40 screws (475-440-1038), from the inside of through to the back shell clamp (431-881-0100). Ensure that proper strain relief and chafing precautions are made during wiring and installation, using the cable clamp (625-001-0002).

Manufacturer	Crimping Tool	Positioner	Extraction tool
AMP	601966-1	601966-6	91067-1
Daniels	AFM8	K42	M24308-1
ITT-Cannon	995-0001-584	995-0001-739	91067-1

Table 1 Connector Pin crimping tools

2.4 Cable Harness Wiring

Referring to the appropriate Appendix, assemble a wiring harness as required for the installation. All wires must be MIL-SPEC in accordance with current regulations. Two- and three-conductor shielded wire must be used where indicated, and be MIL-C-27500 or equivalent specification. Proper stripping, shielding and soldering technique must be used at all times. It is imperative that correct wire be used.

Refer to FAA Advisory Circular 43.13-2A for more information. Failure to use correct techniques may result in improper operation, electrical noise or unit failure. Damage caused by improper installation will void the PS Engineering warranty.

2.4.1 Noise

Due to the variety and the high power of radio equipment often found in today's general aviation aircraft, there is a potential for both radiated and conducted noise interference.

The PMA8000-SR power supply is specifically designed to reduce conducted electrical noise on the aircraft power bus by at least 50dB. Although this is a large amount of attenuation, it may not eliminate all noise, particularly if the amplitude of noise is very high. There must be at least 13.8 VDC present at the connector, J2 pins 8 & 9, of the PMA8000-SR for the power supply to work in its designed regulation. Otherwise, it cannot adequately attenuate power line noise. Shielding can reduce or prevent radiated noise (i.e., beacon, electric gyros, switching power supplies, etc.) However, installation combinations can occur where interference is possible. The PMA8000-SR was designed in a RFI hardened chassis and has internal Electromagnetic Interference (EMI) filters on all inputs and outputs.

Ground loop noise occurs when there are two or more ground paths for the same signal (i.e., airframe and ground return wire). Large cyclic loads such as strobes, inverters, etc., can inject noise signals onto the airframe that are detected by the audio system. Follow the wiring diagram very carefully to help ensure a minimum of ground loop potential. Use only Mil Spec shielded wires (MIL-C-275000, or better). Under no circumstances combine a microphone and headphone wiring into the same shielded bundle. Always use a 2- or 3-conductor, shield wire as shown on the installation-wiring diagram.

The shields can be daisy-chained together, and then connected to a ground lug mounted on the corner of the back plate.

Radiated signals can be a factor when low level microphone signals are "bundled" with current carrying power wires. Keep these cables physically separated. It is very important that you use insulated washers to isolate the ground return path from the airframe to **all** headphone and microphone jacks.

NOTE:

Adding a high-performance audio control system, particularly in conjunction with high-performance active noise canceling headsets, cannot improve on older avionics that were designed for cabin-speaker use. PS Engineering makes no claim that the audio panel will provide a noise-free audio quality under all installation conditions, particularly with older avionics.

2.4.2 Existing GMA340 Installation

In order to replace the GMA340 with a PMA8000SR, the unit tray must be removed and replaced with the new PMA8000 tray. The connectors can be reused. You will have to replace the back plate (430-880-0050) and connect the Satellite Radio antenna to the RF connector (425-880-3003).

2.4.2.1 J2, Pin 30 GMA340

Some GMA340 installations may have a ground strap on J2, Pin 30, Com TX mute.” **THIS CONNECTION MUST BE REMOVED.**

If the PMA8000 installation is routing the SIRIUS Satellite Radio audio externally, this pin is reused as Satellite Radio Audio Right channel. If the Satellite Radio remains internal, this pin must be disconnected.

2.4.3 Power

The PMA8000-SR-Series are compatible with both 14 and 28 Volt DC systems. A five (5) Amp circuit breaker is required for all installations. Power and ground wires must be a twisted #22 AWG pair connected to J2 Pins 8 and 9. Connect airframe ground to J2 Pin 10 and 11 only. No dropping resistors are required.

2.4.4 Communications Push-to-Talk

An important part of the installation is the PTT (Push-To-Talk) switches that allow the use of your aircraft communications radio for transmissions. There are three typical configurations that can be used. Select the case that best fits the installation. Only the person who presses their PTT switch will be heard over the radio. If the pilot and copilot both use the PTT, the only pilot position has access to the radio. The pilot position will have PTT control regardless of the mic selector switch or copilot PTT when the PMA8000-SR is in the OFF/EMG mode.

CASE I: PTT is built into both pilot and copilot yokes.

CASE II: PTT is in pilot yoke only. This configuration requires a modified external PTT switch plugged into the copilot's microphone jack. (See Appendix A). When the copilot's PTT is pressed, the intercom switches the microphone audio from pilot to copilot mic.

CASE III: No built in PTT. This requires two built in PTTs to be installed, or modified external PTT switches to be used. Modify external PTT as required. See Appendix A.

2.4.5 Audio Panel interface

The PMA8000-SR is designed to interface with standard aircraft avionics, and presents a 500Ω receiver impedance. For best results, a twisted-shielded cable is recommended from the avionics audio source to the audio panel, with the shield grounded at the audio panel end.

Some avionics do not provide a separate audio low, and may introduce additional electrical noise into the system. For best results, connect the audio low from the audio panel to the radio ground, using one conductor of the twisted-shielded cable.

2.4.5.1 Speaker Load

The PMA8000-SR contains one speaker amplifier. Some units with internal speaker amplifiers, such as the King Radio KX170-series, require a resistive load to prevent damage if their speaker amplifier is not used.

Connect the speaker output from the unit to the COM 2 Speaker load input on the PMA8000-SR (J1 27 WRT 28). The speaker load is 16 Ω , 3W.

2.4.6 TEL (Duplex) Function for Cell Phones

This mode is designed to operate with telecommunications systems, such as the AirCell Guardian 1000. Audio streams selected by the intercom mode are provided to the Tel output, and audio from Tel is presented to the headset. This allows a telephone-like audio interface.

The TEL mode in the PMA8000-SR is also compatible with many cellular telephones with hands-free headset interfaces. A 1/8" or 3/32" jack can be installed on the aircraft panel, and interfaces with the PMA8000-SR as shown: A patch cord (3/32" to 3/32") is available from PS Engineering under P/N 425-006-7026.

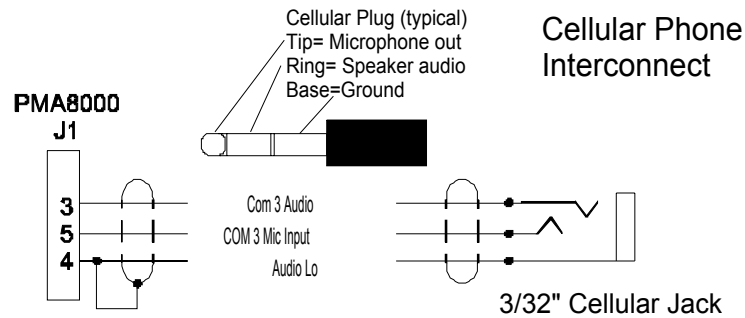

**This is a typical interconnect
PS Engineering does not guarantee
compatibility in all cases.**

Figure 2-1 Cellular telephone interface

Unauthorized use of unapproved cellular telephone devices in aircraft is subject to FCC enforcement action, which may include a \$10,000 fine per incident. PS Engineering, Inc. does not endorse using unapproved cellular telephone equipment in flight, and takes no responsibility for the user's action.

PS Engineering does not guarantee compatibility with personal cellular telephones. For a list of phones that have been tested, visit www.ps-engineering.com.

2.4.7 Transmit Interlock

Some communications transceivers use a transmit-interlock system. To fully utilize the Split Mode feature, this function must be disabled. Consult that manufacturer's installation manual.

2.4.8 Patented "Swap" Mode

When a momentary, normally open, push-button switch is connected between pin 20 on the J2 connector and aircraft ground, the user can switch between Com 1 and 2 by depressing this switch without having to turn the mic selector switch. This yoke-mounted switch eliminates the need to remove your hands from the yoke to change transceivers. The transfer of TX indication from Com 1 to Com 2 shows that the swap has been initiated; there is no dedicated swap indicator.

2.4.9 Backlighting

The PMA8000-SR has an automatic dimming of the pushbutton annunciation LEDs and marker lamps controlled by a photocell. Control of the unit backlighting is through the aircraft avionics dimmer. For 14 V aircraft, connect J2 Pins 6 and 7 to the aircraft dimmer bus, and pin 5 to ground. For 28-volt systems, connect pin 7 to the aircraft dimmer, and pins 5 and 6 to ground.

If an external dimmer control is **not** used, a constant back light illumination can be established for night-time viewing. Pin 6 or 7 (depending on system voltage) must be tied to power (J1, pin 8 or 9) for the back

lighting system to work. The photocell mounted in the unit face will automatically adjust the intensity of the push-button annunciation LEDs.

2.4.10 Unswitched inputs

J1, pins 31, 29 and J2 pin 15 are unswitched, unmuted inputs # 1, 3 and 4, respectively. These inputs are presented to the pilot and copilot regardless of the audio configuration, and will always mute the entertainment inputs. These 510Ω inputs can be used for altimeter DH audio, GPS waypoint audio, autopilot disconnect tones, or any other critical audio signal. Unswitched #1 is always presented to the speaker.

Unswitched #2, J1 pin 44 is unswitched, but muted (controlled by the speaker switch), and suitable for air-to-ground (Flitefone) telephone ringer. This input is not related to the cellular telephone interface. Unswitched 3 and 4 inputs are always presented to the crew headphones and to the aircraft speaker.

NOTE: These inputs are fixed (1:1), and any audio level adjustments must be made at the input source.

Unswitched Input 1 is presented to the pilot in Fail-Safe (power off) condition.

2.4.11 Public Address Mode

Although equipped with a PA mode, the PMA8000-SR is shipped from the factory with this function inhibited, because only a very few customers will use it. It must be initialized before use. The Sirius Radio remote **050-803-0200**, **MUST be used** to initialize the PA Mode. With the Sirius Satellite radio turned on, press **3 0 0** on the remote. You will hear a beep with each key press, followed by the three-beep acknowledgement.

By pressing the Mute and SPR pushbuttons at the same time, the PMA8000-SR will be placed into public address (PA) mode. In this mode, both Mute and SPR indicators will blink, alerting the pilot that when he presses his PTT switch he will be talking over the cockpit speaker. Copilot will still continue on the selected COM radio.

When in the PA mode, J2 Pin 19 will go low, providing a digital logic level that can be used to incorporate a speaker-switching scheme. This can control some switching means such as a relay (coil current of 100 mA maximum) that would transfer the speaker output amplifier from the cockpit speaker to drive another cabin speaker. An internal configuration jumper must be placed in the proper location if Pin 19 is going to be used. This jumper is adjacent to those described in section 2.4.16.4.

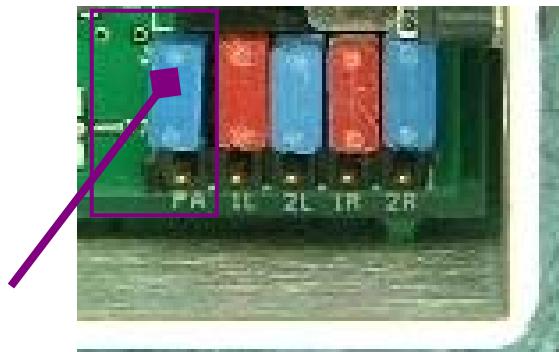

If the PA mode is used with a microphone in proximity to an active cockpit speaker, feedback might result.

2.4.12 PA Mute (J2, Pin 12)

Pin 12 of J2 is a TTL logic output that is pulled low during PTT operation. This serves as an input to external public address system to prevent feedback during transmissions.

2.4.13 Miscellaneous Logic Output (J2, Pin 18)

Pin 18 of the J2 connector is pulled to ground whenever the AUX button is depressed. This serves as a control line for external devices, such as an entertainment system that the pilot wishes to control.

This pin can also be used to control passenger Karaoke Mode, by connecting to pin 13 of the J2, or as a PA cockpit/cabin speaker relay control, as long as the maximum current does not exceed 100 mA..

NOTE: J2, Pin 18 should NOT be used as a logic switch for music muting if the AUX is going to be used to switch DME or auxiliary audio.

2.4.14 Intercom wiring

See Appendix C and D for intercom connection configurations. It is critical to the proper operation of this system to have this connector wiring made in accordance with these diagrams. Use 2- and 3-conductor, MIL-spec cable as shown. Connect the shields at the audio panel end only, and tie to the audio low inputs as shown.

NOTE: The intercom harness can be custom made by PS Engineering, Inc. Simply call the factory or www.ps-engineering.com to obtain a wire harness work sheet. The harness will be made to your specifications and fully functionally tested. Harness can be ordered with jacks, or without the headphone and microphone jacks installed, for easier wire routing through the aircraft.

Installation wiring by anyone other than an approved PS Engineering installer, or a PS Engineering made harness will void the warranty, and may result in an unairworthy aircraft.

2.4.15 SIRIUS Satellite Radio Installation

The SIRIUS Satellite Radio antenna (p/n 510-880-0100) should be mounted on the glareshield using a double-faced tape. Clean the area to remove any dust or grease.

The antenna coax is supplies with a mating connector to the coax pigtail that is installed in backplate. Do not remove the ferrite from the cable.

2.4.16 SIRIUS Satellite Radio Functions

2.4.16.1 SIRIUS Satellite Radio Antenna

The Satellite Radio antenna, part number 510-880-0100, should be mounted on the glareshield with a clear view of the horizon. Avoid mounting behind any electrical sources, such as a heaters, etc. Route the coax to the back of the tray as convenient.

2.4.16.2 SIRIUS Satellite Radio Antenna connection

The Satellite Radio antenna input of the PMA8000-SR must be connected to the Satellite Radio Antenna at the pigtail connected to back plate (P/N 430-890-1481).

2.4.16.3 SIRIUS Satellite Radio Output (J2, Pins 29 & 30)

Satellite Radio audio output, J2, Pin 30 (right) and J2-Pin 29 (left) can be connected to the desired entertainment input pins directly, or externally switched to the desired entertainment input pins.

NOTE:
If the installation replaces a GMS340, and J2, Pin30, was previously grounded, it must be disconnected. Otherwise, the Satellite Radio right channel will be unusable.

2.4.16.4 Sirius Distribution Configuration Jumpers

The music distribution can be configured by the installer to connect the output of the Sirius Module to the Pilot and copilot (Entertainment 1), the Passengers (Entertainment 2) or both. These jumpers are accessible through the top cover of the unit. The jumpers are installed for internal loop back Sirius Satellite Radio from the factory. **This internal configuration allows the installer to retrofit into a GARMIN GMA340 installation without wiring changes.**

Note: The Sirius Radio outputs have an impedance of 510 ohms. When attaching an external music source in parallel with the Sirius radio, be sure the external source can drive 510 ohms or distortion will occur. If the external source cannot drive 510 ohms, these jumpers must be removed or moved to the open position (one leg open as shown below).

To change the internal distribution: Remove the top cover by removing 9 screws from the top cover. Locate the jumper strip near the J2 connector. Remove the jumper plugs to disconnect the Sirius radio output left and right channels, to the entertainment 1 and or entertainment 2 inputs.

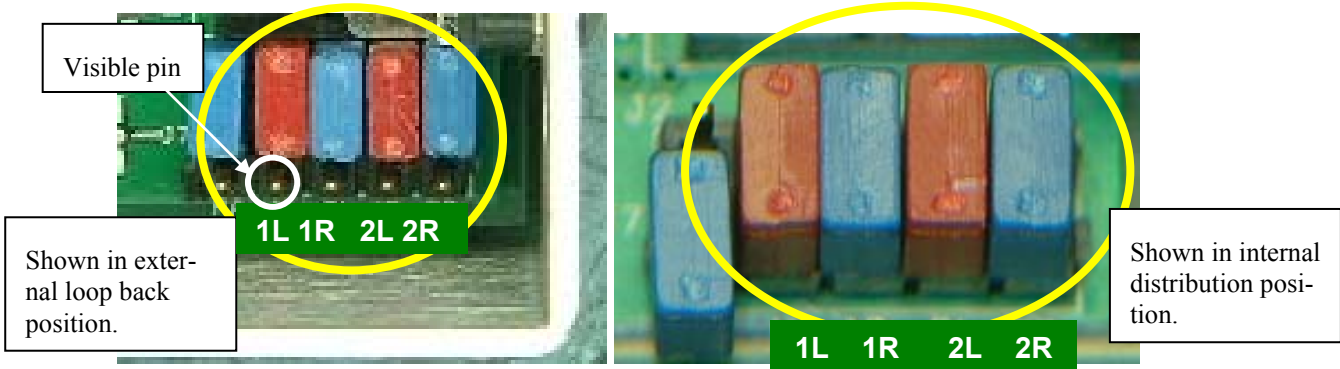

Figure 2-2 Sirius Radio Output Jumpers

2.4.16.5 Entertainment distribution

The PMA8000-SR has two INDEPENDENT music inputs. Entertainment input number 1 is J2 pins 23 (left channel) and 24 (right channel), with respect to pin 25, and is provided to the pilot and copilot. Entertainment number 2 is provided to the passengers at all times, and is connected to 26 (left channel), 27 (right channel), with respect to 28.

Entertainment 1 and 2 must be connected together in order for all positions to hear the same music source, such as the Satellite Radio. We recommend installing a DPDT switch to allow isolation of the music source to the crew and allow the passengers a different entertainment source.

Note: Remember to remove or move internal jumpers to the open position (one leg open as shown above) if the Sirius Radio output is to be connected to another system, an external audio input will be used or anytime the SR Output is connected back into the Entertainment inputs #1 or #2.

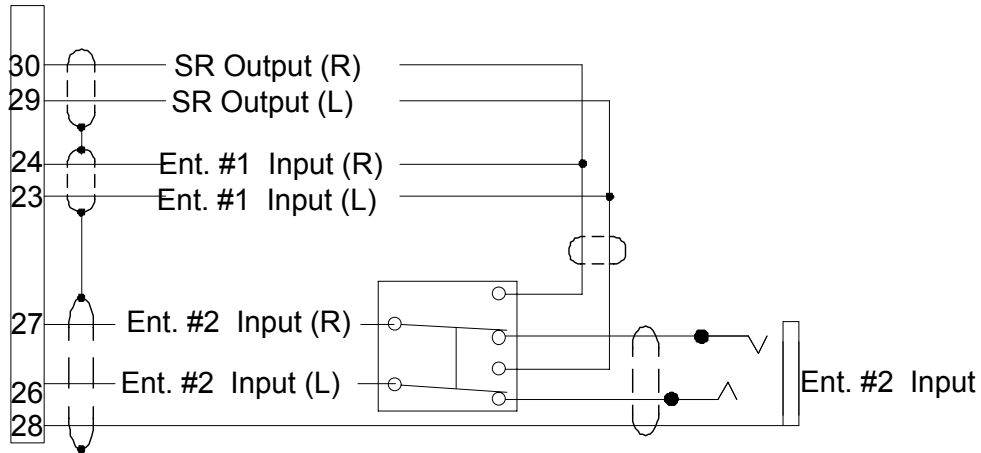

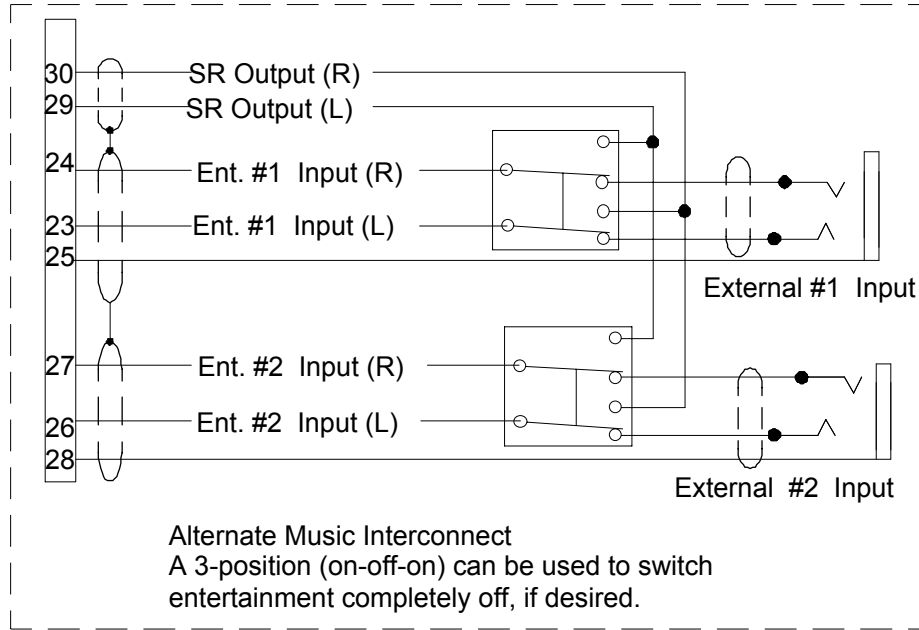

External Music interconnects for Satellite Radio to drive both inputs.
Remove internal jumpers to facilitate external switching.

NOTE: Use the low level output of any additional entertainment device to connect to the audio panel. Maximum signal level is **3 VAC** p-p. **DO NOT** use a speaker-level output, this will cause internal damage in the audio panel.

2.4.17 Use of PXE7300 and PAV 80 AUX inputs for SIRIUS Satellite Radio distribution

The PXE7300 has an auxiliary audio input. This could be used to control the PMA8000-SR Sirius radio audio as the AUX mode.

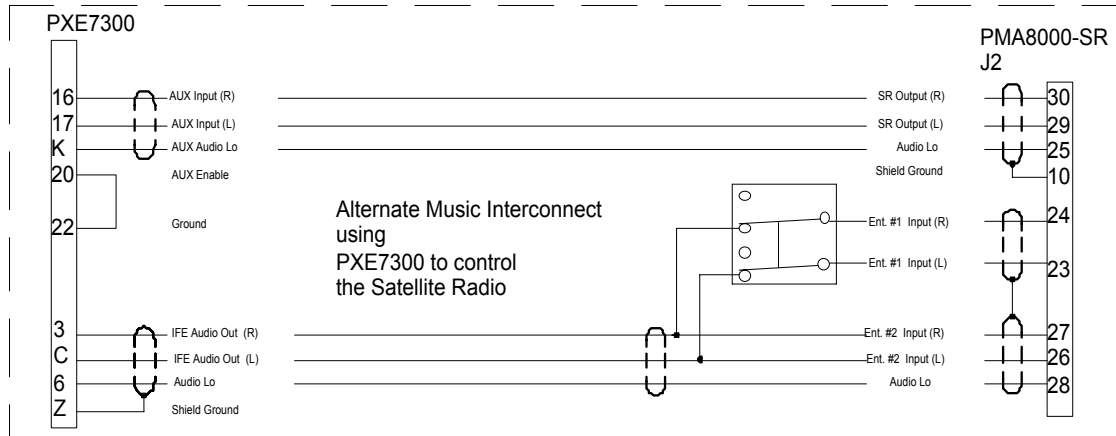

Figure 2-3 PMA8000-SR using PXE7300 as control

The PAV80 also has an auxiliary audio input, and could be used to switch the PMA8000-SR Sirius radio.

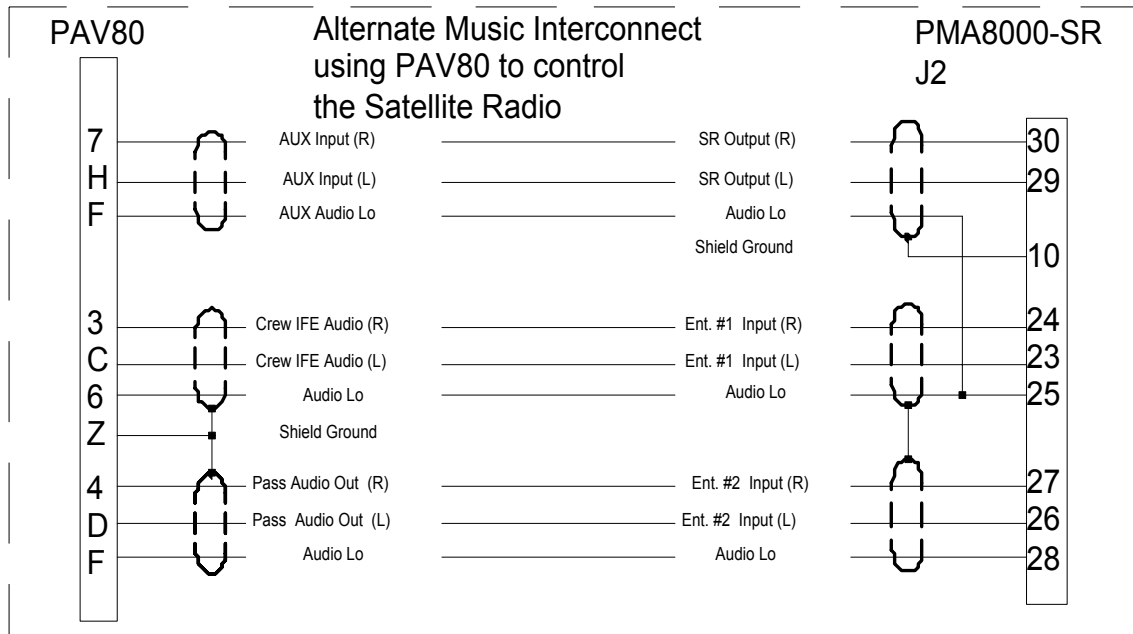

Figure 2-4 PMA8000-SR using PAV80 as control

2.4.18 Entertainment muting

The PMA8000-SR-system incorporates a "Soft Mute" system. This will mute the entertainment devices during ICS or radio conversation.

Any signal appearing in the unswitched audio inputs will always mute the entertainment sources, even though the passengers may not hear the audio tone itself.

Press the Mute switch to activate the Karaoke mode (disabling crew SoftMute™), This allows the pilot to place the entertainment into the background while having the radios in the foreground. This eliminates the constant interruption of the music while still having the radios a priority.

Caution: Local oscillators and internal signals from entertainment equipment can cause undesired interference with other aircraft systems. Before takeoff, operate the entertainment devices to determine if there is any adverse effect within the aircraft systems. If any unusual operation is noted in flight, immediately switch off the entertainment devices.

All additional entertainment devices must be switched off for both takeoff and landing.

2.4.18.1.1 Entertainment 2 Mute (J2 Pin 13 & 14)

Connecting J2 pin 13 to pin 14 (or ground) through a SPST switch places the entertainment #2 music source into the Karaoke Mode. In this mode, incoming music and intercom conversation will not mute the music for the passengers' intercom net. This allows uninterrupted music during casual conversation and at times when radio communications are of lesser importance.

See section 2.4.14 for alternative music connection to allow the passengers and crew to use the same input.

If desired, the AUX button can act as the passengers' mute control. Connect J2 pin 18 (AUX logic) to J2 pin 13 (Entertainment. 2 Mute inhibit). This is NOT recommended as AUX is also used as an audio switch.

2.4.19 Playback button Installation (J2, Pin 22- Option 1, ONLY)

To activate the Recording System playback, a momentary push button switch is required. This switch can be located anywhere in cockpit convenient to the pilot's reach. The switch must be connected to pin 22 of J2 of the PMA8000-SR, and ground

2.5 Marker Beacon Installation

2.5.1 Marker Antenna Installation

A marker beacon antenna, appropriate to the type and speed of the aircraft, is required (not included). Refer to aircraft and antenna manufacturer's installation instructions, as well as AC43.13-2A (or later revision), Chapter 3, for information on proper antenna installation techniques. The marker beacon antenna must be mounted on the bottom of the aircraft.

2.5.2 External Marker Lights

For installations that require external marker beacon lights, there are three outputs that can drive 12-Volt lamps only. The external output lamps are driven high (typically +9 VDC \pm 1.5 VDC unloaded, at MAX brightness) when active. Maximum source current per lamp is 125 mA. Voltage varies with photocell dimming.

2.5.3 Middle Marker Sense (Marker version)

A Middle Marker Sense output signal is available from the 8000 to flight control systems. This function will not operate during the test mode. This output will go to +4.5 VDC (\pm 1.0 VDC) when a valid Middle Marker signal is received. This output is J1, pin 39.

2.6 Adjustments

The PMA8000-SR is factory adjusted to accommodate the typical requirements for most aircraft configurations. There is an adjustment in the bottom cover that allow the installer to tailor speaker volume. Marker Beacon adjustments are on the top cover.

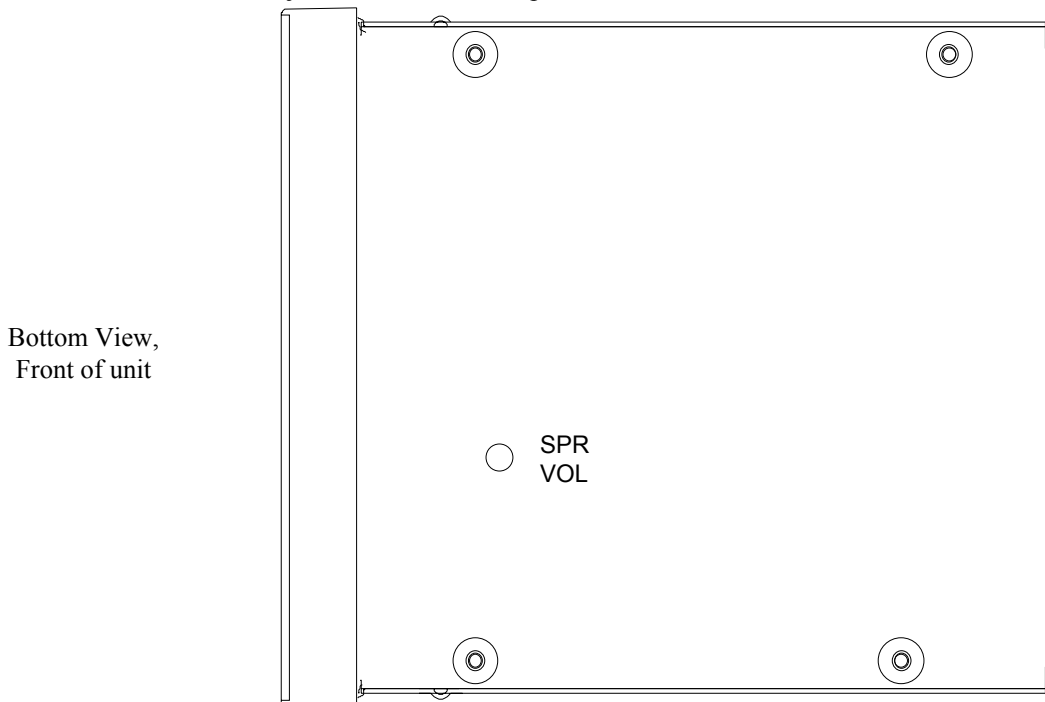

Figure 2-5- PMA8000-SR Bottom Cover Adjustments

- Speaker Volume- Turn adjustment clockwise to increase cabin speaker output.

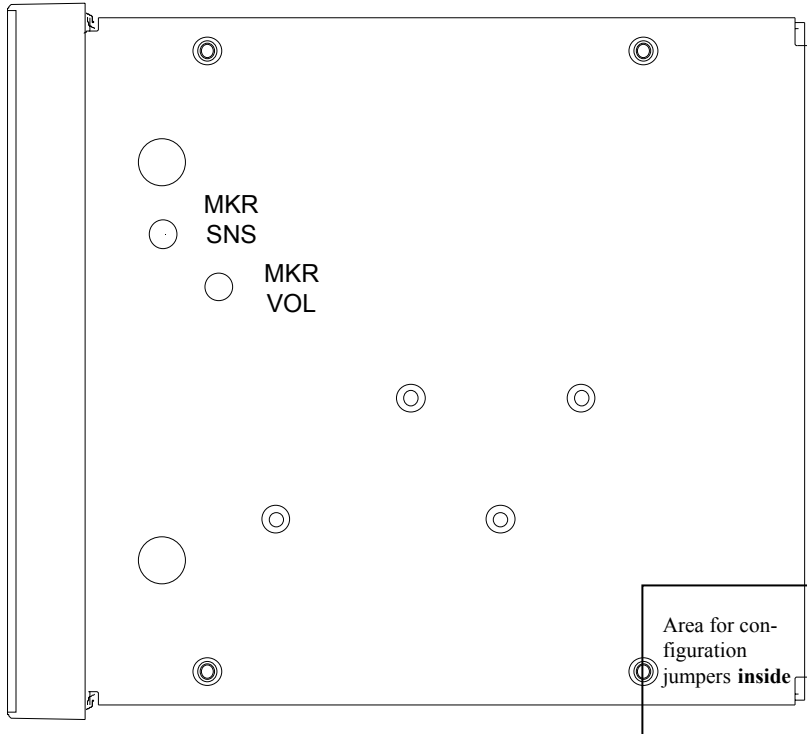

Figure 2-6 Top Cover Adjustments

- Marker Beacon Volume, turn adjustment counterclockwise to increase marker beacon audio level.
- Marker Beacon Sensitivity, Clockwise to increase the marker sensitivity.

2.7 Communications Antenna Installation Notes

For best results while in Split Mode, it is recommended that the one VHF communications antenna is located on top of the aircraft while the other communications antenna is installed on the bottom. Any antenna relocation must be accomplished in accordance with AC 43.13-2A, aircraft manufacturers' recommendations and FAA-approved technical data.

Warning:

It is probable that radio interference will occur in the split mode when the frequencies of the two aircraft radios are adjacent, and/or the antennas are physically close together. **PS Engineering makes no expressed or implied warranties regarding the suitability of the PMA8000-SR in Split Mode.**

2.7.1 Audio Active Output

Pin 24 on the J1 connector (and PA Mute Pin 12 on J2) should be connected to Apollo CNX80 for audio message prioritization, refer to CNX80 installation manual for details.

2.8 PMA8000-SR Pin assignments

J1	Function	J2	Function
1	Mkr Ant	1	Pilot Phones Lo
2	Mkr Ant Lo	2	Copilot Phones Lo
3	Telephone Audio in	3	Copilot Phones (L)
4	Telephone Lo	4	Copilot Phones (R)
5	Telephone Mic Audio	5	Lights lo
6	Telephone Mic Key	6	14/28 V Lights
7	ADF Audio In	7	14/28 V Lights
8	ADF Audio Lo	8	Aircraft Power
9	Com 1 Audio	9	Aircraft Power
10	Com 1 Audio Lo	10	Aircraft Ground
11	Com 1 Mic	11	Aircraft Ground
12	Com 1 Mic Key	12	PA Mute
13	Com 2 Audio	13	Mute Inhibit
14	Com 2 Audio Lo	14	Mute Inhibit Lo
15	Com 2 Mic	15	Unswitched #4
16	No Connect	16	Pilot Phones (L)
17	Nav 1 Audio	17	No connect
18	Nav 1 Audio Lo	18	Misc (AUX) logic output
19	Nav 2 Audio	19	PA Enable
20	Nav 2 Audio Lo	20	Swap
21	DME Audio	21	Swap Lo
22	DME Audio Lo	22	IRS Playback
23	Auxiliary Audio Input	23	Music 1 (L)
24	CNX80 Inhibit	24	Music 1 (R)
25	Music 1 low	25	Music 1 Lo
26	Music 2 low	26	Music 2 (L)
27	Com 2 Speaker Load	27	Music 2 (R)
28	Com 2 Speaker Load	28	Music 2 Lo
29	Unswitched Audio 3	29	SAT Radio output (Lt)
30	Com 2 Mic Key	30	SAT Radio output (Rt)
31	Unswitched # 1	31	Pilot Phones (Rt)
32	Unswitched #1 Lo	32	Copilot Mic Audio
33	Pilot Mic Audio	33	Copilot Mic PTT
34	Pilot Mic PTT	34	Copilot Mic Lo
35	Pilot Mic Lo	35	Pass 1 Mic Audio
36	Ext IM MKR	36	Pass 1 Mic Audio Lo
37	Ext OM MKR	37	Pass 2 Mic Audio
38	Ext MM MKR	38	Pass 2 Mic Audio Lo
39	MM Sense	39	Pass 3 Mic Audio
40	Pass HP (L)	40	Pass 3 Mic Audio Lo
41	Pass HP (R)	41	Pass 4 Mic Audio
42	Pass HP Lo	42	Pass 4 Mic Audio Lo
43	Unswitched #2 Lo	43	Speaker Lo
44	Unswitched #2 Audio	44	Speaker Output

2.9 Post Installation Checkout

After wiring is complete, verify power is ONLY on pins 8 and 9 of the J2 and airframe ground on connector pins 10 and 11. Failure to do so will cause serious internal damage and void PS Engineering's warranty.

2.9.1 Required Test Equipment

In order to return an aircraft to service after installation of the PMA8000-SR, the installer must have access to a Marker Beacon signal generator:

- a. IFR NAV401L, NAV402AP, IFR4000
- b. TIC T-30D, T-36C

Equivalent test equipment is acceptable as long as the testing requirements can be met.

2.10 Unit Installation

To install the PMA8000-SR, gently slide the unit into the mounting rack until the hold-down screw is engaged. While applying gentle pressure to the face of the unit, tighten the 3/32" hex-head in the center of the unit until it is secure. DO NOT OVER TIGHTEN.

Caution: Apply steady pressure to the bezel while screwing the unit into the tray to ensure even seating of the unit and connectors.

Warning: Do not over-tighten the lock down screw while installing the unit in tray.
Internal damage will result.

2.10.1 Operational Checkout

NOTE: The *IntelliVox*® is designed for ambient noise levels of 80 dB or above. Therefore some clipping may occur in a quiet cabin, such as without the engine running, in a hangar. This is normal.

1. Apply power to the aircraft and avionics.
2. Plug headsets into the pilot, copilot, and occupied passenger positions.
3. Verify fail-safe operation by receiving and transmitting on com 1 from the pilot position, with the audio panel power off. The Com audio will be present in one ear cup only.
4. Switch on the unit by pressing the volume (VOL) knob.
5. Check intercom operation.
6. Push the Com 1 Xmt select button (lower row).
7. Verify that both of the **Com 1** buttons light. Verify that transmit button LED (Light Emitting Diode) near the mic selector is not blinking. If the LED is blinking, stop testing and troubleshoot the microphone PTT installation.
8. Verify proper transmit and receive operation from the copilot position, noting that the copilot PTT switch allows proper transmission on the selected transceiver. Verify that the Com 1 Xmt button blinks when transmitting.
9. Verify that pushing the **COM 2** button causes the button to illuminate, and the Com 2 receiver to be heard. Verify operation on Com 1 from the pilot position.
10. Repeat for Com 2
11. Press and hold the Com 1 Xmt button. While holding the Com 1 button, press the Com 2 Xmt button. This places the unit in "split Mode;" Verify that the pilot can transmit and receive on Com 1, while the copilot transmits and receives on Com 2.
12. Verify proper operation of all receiver sources by selecting them using the appropriate button. The button illuminates to show which source is in use.

13. Push the SPR button. Verify that all selected audio is heard in the cockpit speaker. Verify that the audio mutes when the mic is keyed.
14. Verify that the appropriate LED in the lower button row blinks when either push to talk is keyed.
15. Verify proper Intercom system operation in the **ALL**, **ISO** and **CREW** modes (see Table 3-1).
16. Verify that the audio selector panel system does not adversely affect any other aircraft system by systematically switching the unit on and off, while monitoring the other avionics and electrical equipment on the aircraft.

2.10.1.1 Marker Beacon Checkout

1. Connect a ramp generator listed in section 2.9.1 at the antenna end of the marker coax. With the unit under test in HI sensitivity, verify that a 160 μ V, modulated 95% with 1300 Hz, signal will illuminate the amber (M) marker light, and that marker audio is present in the headphones when the Marker Audio (M) push-button has been depressed. Select SPR for speaker to verify marker audio availability on the cabin speaker. Verify that the white (I) and blue (O) lights will illuminate within \pm 3dB of the amber lamp, with 3000 HZ and 400 Hz applied, respectively.
2. Repeat with the unit in LOW sensitivity, with 430 μ Volts applied.
3. Connect the marker antenna and verify proper operation.

2.11 TEL Checkout

Press the TEL button. Verify that the pilot headset is connected to the cellular telephone system (if installed). Verify that by using the pilot side PTT, the pilot can transmit on the other selected radio (Com 1 or Com 2).

When a wireless telecommunication system is installed, a dial tone will appear in the headset of the pilot when the TEL selector is activated. The telephone function will place any person heard by the pilot on the intercom, also heard on the telephone.

2.12 SIRIUS Satellite Radio checkout

Because the SIRIUS Satellite Radio will not announce channel numbers until the radio is activated by the user, an audio channel test is provided. Using the remote control, Press "3-4-5-enter" on the keypad to generate a 1kHz tone. This will be provided to any station connected to the internal SIRIUS Satellite Radio module. Enter the same code to turn it off again.

To exercise the voice annunciations for the SIRIUS Module, press "6-7-8-enter" to playback all annunciations. Press any key on the remote to stop the playback.

To verify that the antenna is receiving adequate SIRIUS Satellite Radio signals, press 9-0-1 on the remote control. This will play the numeric value of the signal strength as follows; two beeps, Satellite 1 value (0-255) and beep, followed by Satellite 2 (0-255) beep again, and then read back terrestrial value. The final value will probably be either a "1" or "zero" unless a terrestrial antenna is nearby. Higher numbers are better signals, but you will probably receive only one satellite at a time.

2.12.1 Sirius Signal Dropout

NOTE: SIRIUS Satellite Radio uses ground-based transmitters in populated areas to ensure consistent road coverage. However, for airborne receivers, these ground-based signals may cancel satellite-transmitted signals, resulting in a dropped signal. You may experience interruptions in the airborne SIRIUS signal near large cities. This interruption will be variable, depending on AGL altitude, distance, number of ground-based transmitters and azimuth to the transmitters.

PS Engineering, Inc. does not guarantee SIRIUS Satellite Radio coverage in all areas, or the suitability of the SIRIUS Satellite Radio for any particular geographical area.

2.12.2 SIRIUS Satellite Radio ID number

The SIRIUS Satellite Radio identification number can be played back through the annunciation. Have a pencil handy, and press “4-1-1” on the remote control.

2.13 Internal Recorder Checkout (Optional)

With headset plugged into pilot's side jacks, tune COM 1 to local frequency, such as FSS or ATC ground. Select Com 1 on mic selector switch, and record at least five incoming radio transmissions.

This audio should only appear in the pilot's headset, and only be incoming transmissions from the transceiver selected in the mic select switch. Depress the panel or yoke mounted playback switch, and verify that messages play, in the order received. Repeat for COM 2, and COM 3 (if installed).

2.14 Final Inspection

Verify that the wiring is bundled away from all controls and no part of the installation interferes with aircraft control operation. Move all controls through their full range while examining the installation to see that no mechanical interference exists. Verify that the cables are secured to the aircraft structure in accordance with good practices, with adequate strain relief. Ensure that there are no kinks or sharp bends in the cables and coaxial cables. Verify that the cables are not exposed to any sharp edges or rough surfaces, and that all contact points are protected from abrasion.

Complete logbook entry, FAA Form 337, weight and balance computation and other documentation as necessary. Sample text for FAA Form 337, and instructions for continuing airworthiness can be found in Appendix F.

Return completed warranty registration application to PS Engineering or register online at www.ps-engineering.com.

Section III OPERATION

GENERAL INFORMATION

3.1 SCOPE

This section provides detailed operating instructions for the PS Engineering PMA8000-SR, Audio Selector Panel/Intercom Systems. Please read it carefully before using the equipment so that you can take full advantage of its capabilities.

This section is divided into four sections covering the basic operating areas of the PMA8000-SR systems. They are Communications Transceiver Selection, Audio Selector, Intercom, and Marker Beacon Receiver.



Figure 3-1 PMA8000-SR front panel

3.2 Power Switch (1) (EMG-Fail Safe Operation)

Unit power is turned on and off by pushing the volume knob. In the OFF or "EMG" position, the pilot is connected directly to Com 1. This allows communication capability regardless of unit condition. Any time power is removed or turned OFF, the audio selector will be placed in the fail-safe mode.

The power switch also controls the audio selector panel functions, intercom and marker beacon receiver.

3.3 Microphone (2) (XMT) Selection (All models)

There are four pushbuttons associated with the communications transceivers. The lower buttons (item 2) control which transceiver is selected for transmit, the top row of COM 1 and COM 2 allows selection of the receive audio.

The PMA8000-SR gives priority to the pilot's PTT. If the copilot is transmitting, and the pilot presses his PTT, the pilot's microphone will be transferred to the selected com transmitter.

The PMA8000-SR-Series has an automatic selector mode. Audio from the selected transceiver is automatically heard in the headsets and speaker (if selected). You can check this function by switching from COM 1 to COM 2 XMT mode and watch the selected RCV light on the selector change from COM 1 to COM 2. This ensure the pilot will *always* hear the audio from the transceiver he is transmitting on.

When switching from COM 1 to COM 2, while COM 2 audio had been selected, Com 1 audio will continue to be heard. This eliminates the pilot having to switch Com 1 audio back on, if desired.

When switching from COM 1 to COM 2 while Com 2 has NOT been selected, Com 1 audio will be switched off. In essence, switching the mic selector will not effect the selection of Com receiver audio.

In TEL mode, the pilot microphone and headphones are connected to the cell phone. The pilot PTT will switch the pilot mic to the selected com transceiver, and allow continued aircraft communications to continue.

The copilot will also be able to transmit on the other selected radio with his PTT as well.

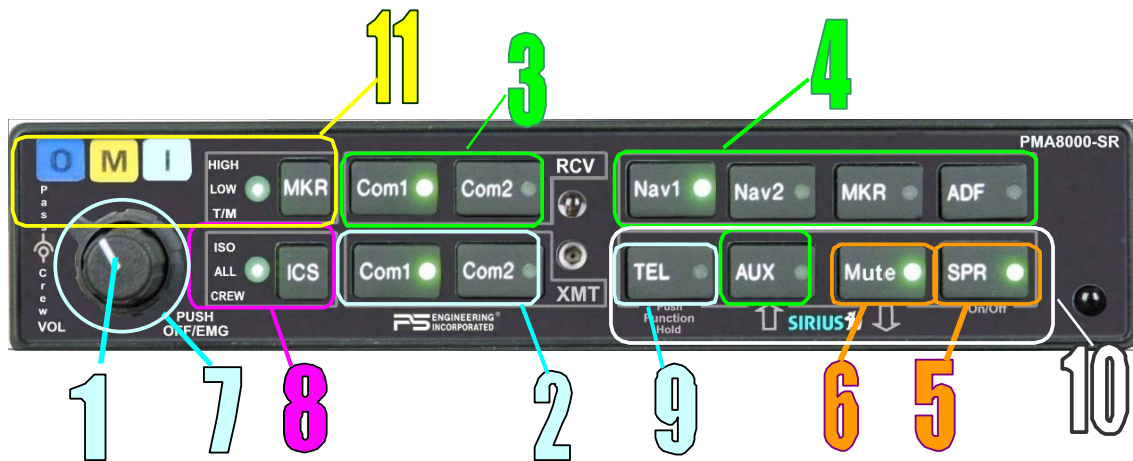

Figure 3-2 PMA8000-SR Operating controls

NOTE: Placing the PMA8000-SR in-TEL-

The intercom mode pushbutton determines who is on the phone, and who is still on the intercom. In ISO, only the pilot is on the phone, while the copilot and passengers remain on intercom. The pilot will continue to hear all selected aircraft radios. In the ALL mode, everyone will be on the phone, intercom, and hear aircraft radios, and: In Crew mode, the pilot and copilot will be on the phone and hear aircraft radios, while the passengers will be on intercom.

3.3.1 Swap Mode (Switch from Com 1 to Com 2 remotely)

With a yoke mounted, momentary switch, the pilot can change from the current Com transceiver to the other by depressing this switch. To cancel "Swap Mode," the pilot may either press the yoke mounted switch again, or select a different Com with the XMT buttons. .

3.4 Audio Selector (4)

Receiver audio is selected through seven momentary, push-button, backlit switches. You will always hear the audio from the transceiver that is selected for transmit.

The users can identify which receivers are selected by noting which of the green switch LEDs are lit. Push buttons labeled **Nav 1**, **Nav 2**, **MKR** (Marker), **ADF** and **AUX** (auxiliary) places those receivers into the audio stream. DME audio (if present) will come through when the AUX button is selected. When one of these buttons is pressed, the mode is active, and the LED will illuminate. Press the switch again and it will be "off" and remove that receiver from the audio output.

3.4.1 Speaker Amplifier (5)

The "**SPR**" in the push-button section stands for speaker. This switch will place all selected audio on the cockpit speaker when this switch is selected. NOTE: Except for the unswitched audio, the speaker amplifier is not active in the "Split Mode".

Unswitched audio input 1, (the input dedicated to autopilot disconnect, altimeter warning, etc.) will come through the speaker regardless of the speaker button position. Unswitched audio input 2, (the input dedicated to a lesser importance input such as GPS waypoint alert) will come through the speaker only when the SPR mode is on. Consult your installer for more information.

3.4.1.1 Public Address Initialization

When shipped from the factory, the Public Address function is inhibited. To initialize the PA function, **you must have the Sirius Remote Control**. Press **3 0 0** on the keypad to initialize the PA function. You will

hear a beep with each key press, followed by three acknowledgement beeps. This must be accomplished only once and the PMA8000-SR will “remember” that PA is activated. See section 3.4.1.2 to use the PA mode.

3.4.1.2 Public Address Function

To use PA function, press the **Mute** (6) and **SPR** (5) buttons simultaneously. The **SPR** and **MUTE** LEDs will blink to indicate the audio panel is in PA mode. The copilot can continue to use the selected com radio while the pilot will be heard over the speaker. To exit, press **Mute** and **SPR** again.

We recommend that some switching means be used to transfer the audio from the cockpit speaker to a cabin speaker for public address. This will prevent feedback. See section 2.4.11

3.5 Split Mode

The split mode can be activated at any time by pressing the Com 1 and Com 2 XMT buttons at the same time. This places the pilot on Com 1 and the Copilot on Com 2.

Pilot on Com 2 and Copilot on Com 1 is not possible.

Note:

Due to the nature of VHF communications signals, and the size constraints in general aviation aircraft, it is probable that there will be some bleed-over in the Split mode, particularly on adjacent frequencies.
PS Engineering makes no warranty about the suitability of Split Mode in all aircraft conditions.

Note: Split Mode does not turn off other (Nav, ADF, etc.) selected audio to **pilot**. However, the copilot will only hear the selected communications receiver.

3.5.1 Mute Button, Split Mode ICS (6)

In split mode, the pilot and copilot are usually isolated from each other on the intercom, simultaneously using their respective radios. Depressing the “**Mute**” button (6) in Split Mode will activate VOX intercom between the pilot and copilot positions. This permits intercommunication when desired between the crew. Pressing the **Mute** button again disables this crew intercom function.

3.6 Intercom Operation

3.6.1 IntelliVox® VOX-Squelch

No adjustment of the *IntelliVox*® squelch control is necessary. There is no field adjustment. Through three individual signal processors, the ambient noise appearing in all six microphones is constantly being sampled. Non-voice signals are blocked. When someone speaks, only their microphone circuit opens, placing their voice on the intercom.

The system is designed to block continuous tones, therefore people humming or whistling in monotone may be blocked after a few moments.

For consistent performance, any headset microphone **must** be placed within ¼-inch of your lips, preferably against them. (ref: *RTCA/DO-214, 1.3.1.1 (a)*).

It is also a good idea to keep the microphone out of a direct wind path. Moving your head through a vent air stream may cause the *IntelliVox*® to open momentarily. This is normal.

The *IntelliVox*® is designed to work with normal aircraft cabin noise levels (70 dB and above). It loves airplane noise! Therefore, it may not recognize speech and clip syllables in a quiet cabin, such as in the hangar, or without the engine running. This is normal.

For optimum microphone performance, PS Engineering recommends installation of a Microphone Muff Kit from Oregon Aero (1-800-888-6910). This will not only optimize VOX performance, but will improve the overall clarity of *all* your communications.

Table 3-1 Mic Muff™ Part Numbers

Manufacturer	Model	Mic Muff™ Part Number
Bose	Dynamic	90010
	Electret	90015
	M87 Dynamic	90020
David Clark	H10-30	90010
	H10-20, H10-40	90015
	H10-13.4	90015
Lightspeed	All	90015
Peltor	7003	90010
	7004	90015
Pilot	11-20 & 11-90	90015
Sennheiser		90015
Telex	Airman 750, Echelon	90015
	AIR3000	90010

3.6.2 Intercom Volume Control (7)

The inner volume control knob adjusts the loudness of the intercom for the pilot and copilot. It has no effect on selected radio levels, music input levels or passengers' volume level.

The outer volume control knob controls intercom volume or the passengers. It has no effect on radio or music levels.

Adjust the radios and intercom volume for a comfortable listening level. Most general aviation headsets today have built-in volume controls; therefore, volume also can be further adjusted at the individual headset.

3.6.2.1 Mono headsets in Stereo Installation

All passenger headsets are connected in parallel. Therefore, if a monaural headset is plugged in to a PMA8000-SR Stereo installation, one channel will be shorted. Although no damage to the unit will occur, all passengers will lose one channel, unless they switch to the "MONO" mode on the headset. PS Engineering modifies headsets to add stereo capability, using high-fidelity speakers. Contact factory for details.

3.6.3 Intercom Modes (8)

The "ICS" pushbutton switch on the left side of the panel provides the selection of the three intercom modes. The description of the intercom mode function is valid only when the unit is not in the "Split" mode. Then, the pilot and copilot intercom is controlled with the **Mode** button.

This button cycles through the intercom modes, from top to bottom, then bottom to top as: ISO, ALL Crew and Crew, ALL, ISO. An LED shows which mode is currently active.

ISO: The pilot is isolated from the intercom and is connected only to the aircraft radio system. He will hear the aircraft radio reception (and sidetone during radio transmissions). Copilot will hear passengers' intercom and Entertainment 1, while passengers will hear copilot intercom and Entertainment 2. Neither will hear aircraft radio receptions or pilot transmissions.

ALL: All parties will hear the aircraft radio and intercom. Crew will hear Entertainment 1, passengers will hear Entertainment 2. During any radio or intercom communications, the music volume automatically decreases. The music volume increases gradually back to the original level after communications have been completed.

CREW: Pilot and copilot are connected on one intercom channel and have exclusive access to the aircraft radios. They may also listen to Entertainment 1. Passengers can continue to communicate with themselves without interrupting the Crew and may listen to Entertainment 2.

3.6.3.1 Entertainment Input

As shipped from PS Engineering, the PMA8000-SR is configured to provide Sirius Satellite Radio to the Entertainment #1 circuit, for Pilot and Copilot. Since the audio selector panel has provisions for two separate entertainment inputs, which operate independently the Sirius Radio audio can be directed to the passengers. The front panel volume control does not affect the music level. Music 2 feeds the passengers. Passenger music also operates independently from the crew (music 1).

While in the ISO (Isolate) mode, the copilot will hear Entertainment 1 while the four passengers will hear Entertainment #2. The pilot will hear entertainment 1, at a very muted level. The music will automatically mute when either the copilot or passengers speak and then will gradually return to the original listening level when the intercom or radio conversation ceases. Pilot will not mute the music while in ISO mode if he presses the PTT switch to transmit or if he speaks while on the phone.

When in the ALL mode, pilot and copilot hear Entertainment 1 input, while all passengers hear the Entertainment 2 source. Music 1 will mute, or can be placed in Karaoke mode by pressing the “**Mute**” (6) pushbutton. The passengers can disable their music muting with an external switch that may have been installed during installation.

While in the CREW mode, pilot and copilot will hear entertainment input #1 while the passengers will listen to entertainment input #2.

3.6.3.2 Soft Mute and Soft Mute inhibit for Karaoke Mode

The Soft Mute feature assures that the aircraft radio transmissions will not be missed due to entertainment playing. When there is radio reception or intercom conversation, the music level is dropped to a low, or background level. When the radio or intercom traffic ceases, the level gradually returns to normal.

The “**Mute**” pushbutton switch, (6) controls muting of entertainment source #1 (for pilot and copilot). Pushing this button places music input 1 into Karaoke (or sing along) mode. This allows the music to continue uninterrupted by intercom or radio traffic when cockpit workload is appropriate. Pushing the button again will release the mute inhibit function.

The passenger music, source #2, can be placed in the Karaoke mode by pressing the AUX button, if wired to AUX logic output, or if a remote switch is installed in the aircraft. See wiring information for details.

Mode	Pilot Hears	Copilot Hears	Passenger Hears	Telephone	Comments
Isolate	A/C Radios Pilot Sidetone (during radio transmission) Entertainment 1 is Muted	Copilot and passenger intercom Entertainment #1	Passenger and Copilot intercom Entertainment #2	“Phone Booth” mode Pilot has exclusive use of the telephone. In TEL, Pilot connected to selected COM for PTT TX and receive.	This mode allows the pilot to communicate without the others bothered by the conversations. Copilot and passengers can continue to communicate and listen to music
All	Pilot Copilot A/C Radio Passengers Entertainment #1	Copilot Pilot A/C Radio Passengers Entertainment #1	Passengers Pilot Copilot A/C Radio Entertainment #2	All have access to phone .	This mode allows all on board to hear radio reception as well as communicate on the intercom. Music and intercom is muted during intercom and radio communications
Crew	Pilot Copilot A/C Radio Entertainment #1	Copilot Pilot A/C Radio Entertainment #1	Passengers Entertainment #2	Pilot and copilot have phone access.	This mode allows the pilot and copilot to concentrate on flying, while the passengers can communicate amongst themselves.

Table 3-2 Intercom Modes

3.7 Telephone Mode (9)

The TEL mode serves as a full duplex interface for telephone systems such as AirCell or portable cellular phones with earpiece jacks. When interfaced with an approved airborne telecommunications system, the PMA8000-SR can serve as an audio control and distribution center.

In **ALL** intercom mode, all crew and passengers will be heard on the phone when they speak. All will hear selected audio. Com audio is automatically heard in the headsets.

In **CREW** mode, the pilot and copilot are connected to the telephone. The pilot and copilot will have transmit capability on the other selected transceiver Com 1 or 2, simply by using their respective PTT switch.

In **ISO** intercom mode, when the PMA8000-SR is in the **TEL** mode, the pilot position is in the "Phone Booth." Only the pilot will hear the telephone, and only he will be heard. He will also have access to Com 1 or 2, and will transmit on that radio using the PTT. All selected audio is provided.

Note: Because the cellphone uses an intercom circuit, all stations on that circuit will lose intercom capability when the cellphone is in use.

PS Engineering does not guarantee compatibility with personal cellular telephones.
Visit www.ps-engineering.com for a list of phones that have been tested.

3.8 SIRIUS Satellite Radio Operation (10)

Primary operation of the SIRIUS satellite radio module is through the portable remote control, PN 051-880-0150. This device must be pointed at the PMA8000 front panel to control the satellite function.

The Remote has the following functions:

- SIRIUS Mode Module on/off (does NOT affect audio panel/intercom/marker beacon operation)
- Direct channel selection
- Volume control
- SIRIUS Radio mute
- Next/last channel
- Next/last category
- Channel store and recall for favorite channels
- "Query" button to playback channel in use
- "Scan" button that allows the user to sample channels in order

NOTE: The Satellite Radio audio follows the same muting rules, and will be muted automatically unless the Karaoke mode is enabled.

To turn the Satellite Radio on, press the **On/Off** button. A voice will say, "Power on." The satellite radio will begin to play on the last used channel. To turn the SIRIUS radio off, press the button again. This will be indicated by two beeps.

To change the channel, simply press the digits (**0 through 9**). As soon as the first digit is pressed, the audio will beep indicating a button has been pressed. If another digit is not pressed within two seconds, the SIRIUS will change to the new channel, and announce "Channel, followed by the selected channel number.

When selecting the channel directly, you may either press "enter" to accept the change immediately. If no "enter" is pressed, the radio will change channels approximately 2 seconds after the last digit.

The **NEXT CH** and **PREV CH** buttons move to the next higher (or lower) channel number, and will say the channel number.

The **NEXT CAT** and **PREV CAT** buttons will change to the first channel in the next higher (or lower) category, such as from Pop to Rock, Country, Hip-Hop, R&B, Dance, Jazz, Classical, Latin, News, Sports, Entertainment and back to Pop.



Press the volume up and down (**VOL UP**, **VOL DN**) buttons to change the satellite radio volume through the audio panel. This will only adjust the SIRIUS Radio and SIRUIS Radio annunciations, nit intercom or other volume. A beep will be heard when the volume button is first pressed.

The Mute button will silence the SIRIUS audio, but not the audio annunciations. This is not related to the intercom SoftMute™ function.

Pressing the “**Q**” query button will playback the selected channel number.

To save your favorite SIRIUS channel, press the “**SET**” button on the remote (there will be a beep), followed by the recall button (1 thru 6). To recall, simply press the numeric recall button. The audio will announce “Recall channel __”, and then change.

The last channel button can be used to switch back and forth between recent channels.

The SCAN button will sample the audio for three seconds, and then change to the next higher channel.

3.8.1 Sirius Signal Dropout

NOTE: SIRIUS Satellite Radio uses ground-based transmitters in populated areas to ensure consistent road coverage. However, for airborne receivers, these ground-based signals may cancel satellite-transmitted signals, resulting in a dropped signal. You may experience interruptions in the airborne SIRIUS signal near large cities. This interruption will be variable, depending on AGL altitude, distance, number of ground-based transmitters and azimuth to the transmitters.

PS Engineering, Inc. does not guarantee SIRIUS Satellite Radio coverage in all areas, or the suitability of the SIRIUS Satellite Radio for any particular geographical area.

3.8.2 Front panel control of SIRIUS Radio

In addition to the Remote, the basic controls can be accessed through the front panel. These front panel controls are located along the bottom row of buttons. Hold the “Function” button

while accessing the other Sirius functions.



Figure 3-4 SIRIUS Radio Front Panel Controls

To turn the Sirius module on, press and hold the Function (“**TEL**”) button, while pressing the On/Off (“**SPR**”) button. You will hear a “power on” indicating that the unit is turned on. To turn the module off, repeat the sequence. You will hear “power off” to acknowledge that the unit is shutting down.

NOTE: The SIRIUS Radio Module will be turned OFF when power is initially applied to the audio panel. If you believe that there is a malfunction in the SIRIUS Satellite Radio, turn power off, and back on.

Hold the function button (**TEL**), press and hold the **Mute** button to decrease the SIRUIS radio volume. Hold the function button press and hold the **AUX** button to increase the SIRIUS radio volume.

Hold the function (**TEL**) button, and briefly press the **Mute** button to increase the SIRUIS radio channel. Hold the function button and briefly press the **AUX** button to reduce the SIRIUS radio channel.

When the channel controls are activated you will hear the voice announce the channel. This will allow you to hear the SIRIUS channel selected, even if you are not receiving a signal.

When the channel controls are activated you will hear the voice announce the channel. This will allow you to hear the SIRIUS channel selected, even if you are not receiving a signal.

NOTE: To turn OFF the satellite radio from the PMA8000 panel without using the remote, push the “TEL” and “SPR” buttons at the same time. If you believe that there is a malfunction in the SIRIUS Satellite Radio, turn power off, and back on to restore audio panel functions.

3.9 Marker Beacon Operation (10)

The Marker Beacon Receiver uses visual and audio indicators to alert you when the aircraft passes over a 75 MHz transmitter.

The Blue lamp, labeled "O", is the Outer Marker lamp and has an associated 400-Hertz 'dash' tone. The lamp and tone will be keyed at a rate of two tones/ashes per second when the aircraft is in the range of the Outer Marker Beacon.

The Amber lamp, labeled "M", is the Middle Marker lamp and is coupled with a 1300 Hertz tone. It is keyed alternately with short 'dot' and long 'dash' bursts at 95 combinations per minute.

The White lamp, labeled "I", is the Inner marker and has a 3000-Hertz 'dot' tone. The lamp and tone will be keyed at a rate of six times per second.

The audio from the Marker Beacon Receiver can be heard by selecting the "MKR" push-button switch. To adjust the volume level, there is a service adjustment located on the top of the unit.

A pushbutton is used to set the receiver sensitivity and to test the indicator lamps. Use "HI" sensitivity initially. This allows you to hear the outer marker beacon about a mile out. Then touch the smaller MKR button to switch into Low Sensitivity mode. "LO" sensitivity gives you a more accurate location of the Outer Marker. Holding the MKR button for two seconds activates marker test lamp, labeled "T/M" and illuminates all three lamps simultaneously to assure the lamps (internal and external) are in working order. TST does not activate MM autopilot sense output. Releasing the button returns to the last sensitivity.

Pressing the marker mode select (to "T/M") for two seconds will also cause the marker audio to mute for that beacon. The next beacon received will re-activate the audio.

3.10 Internal Recorder System (Option 1)

The Intercom Recording System is a digital recording system allowing automatic storage and playback of aircraft radio traffic.

Operating as a continuous loop recorder, (first message received will be the last heard), the recorder has one minute of recording time or up to 16 messages. With its own built in VOX circuit, there are no buttons to press to start recording. The system automatically begins to record the instant the radio becomes active. Only aircraft radio audio in pilot's headset is recorded and only the pilot will hear the playback audio.

3.11 Operation

Recording is automatic. To play back the last recorded message, simply press the switch associated with the IRS. Each additional press of the button will play the preceding recorded message. You must wait for the message to finish playing before accessing the prior message. To cancel the playback, press and hold the playback button for two seconds. The next time the button is pressed, the next earlier message will be heard.

Section IV- Warranty and Service

4.1 Warranty

In order for the factory warranty to be valid, the installations in a certified aircraft must be accomplished by an FAA-(or other ICAO agency) certified avionics shop and authorized PS Engineering dealer. If the unit is being installed by a non-certified individual in an experimental aircraft, a factory-made intercom harness must be used for the warranty to be valid.

PS Engineering, Inc. warrants this audio panel portion of this product to be free from defect in material and workmanship for a period of three (3) years from the date of sale. During the first **twelve (12) months** of the three-year warranty period, PS Engineering, Inc., at its option, will send a replacement unit at our expense if the unit should be determined to be defective after consultation with a factory technician. For the remaining **twenty-four (24) months** of the three-year warranty period, the unit must be returned to PS Engineering, Inc., or an authorized warranty service facility, for no-cost repair.

The Sirius Radio Receiver portion of the product is warranted to be free from defect in material and workmanship for a period of one (1) year from the date of sale.

All transportation charges for returning the defective units are the responsibility of the purchaser. All domestic transportation charges for returning the exchange or repaired unit to the purchaser will be borne by PS Engineering, Inc. The risk of loss or damage to the product is borne by the party making the shipment, unless the purchaser requests a specific method of shipment. In this case, the purchaser assumes the risk of loss.

This warranty is not transferable. Any implied warranties expire at the expiration date of this warranty. PS Engineering SHALL NOT BE LIABLE FOR INCIDENTAL OR CONSEQUENTIAL DAMAGES. This warranty does not cover a defect that has resulted from improper handling, storage or preservation, or unreasonable use or maintenance as determined by us. This warranty is void if there is any attempt to disassemble this product without factory authorization. This warranty gives you specific legal rights, and you may also have other rights, which may vary from state to state. Some states do not allow the exclusion of limitation of incidental or consequential damages, so the above limitation or exclusions may not apply to you.

All items repaired or replaced under this warranty are warranted for the remainder of the original warranty period. PS Engineering, Inc. reserves the rights to make modifications or improvements to the product without obligation to perform like modifications or improvements to previously manufactured products.

4.2 Factory Service

The units are covered by a three-year limited warranty. See warranty information. Call PS Engineering, Inc. at (865) 988-9800 before you return any unit. This will allow the service technician to provide any other suggestions for identifying the problem and recommend possible solutions.

After discussing the problem with the technician and you obtain a Return Authorization Number, ship product to:

PS Engineering, Inc.
Attn: Service Department
9800 Martel Rd
Lenoir City, TN 37772
(865) 988-9800 FAX (865) 988-6619
Email: support@ps-engineering.com

Units that arrive without an RMA number, or telephone number for a responsible contact, will be returned un-repaired. PS Engineering is not responsible for items sent via US Mail.

Appendix A External PTT Hook Up

Part of the installation includes the installation of PTT (Push To Talk) switches that allow the use of your aircraft radio for communications transmissions.

There are three possible configurations ; you must select the case that best fits your installation. NOTE: Only the person who presses their PTT switch will be heard over the radio.

CASE I

The PTT is built into the pilot and copilot yokes

Simply install the plugs from the headset into the aircraft headphone jacks. Then use the yoke mounted PTT to transmit. No other action is required.

CASE II

Built in PTT only on the pilot side only

This configuration requires a modified external PTT switch plugged into the copilot's mic jack. (See Details Below) When the copilot's PTT is depressed, this activates an internal relay that switches the mic audio to the aircraft radio from the pilot to the copilot.

Case III

No built in PTT switch at all.

Two built-in PTT must be installed, or two external, modified PTT switches will be required for both the pilot and copilot. Modifications to the PTT are required. (See details below)

Push To Talk Modifications

When received from the manufacturer, an after-market PTT switch opens the mic audio path to the "ring" connection of the PTT mic plug until the button is pressed. When the PTT is between the intercom and the headset, the intercom function will not work unless the PTT switch is depressed. A simple modification can be performed to allow proper intercom operation. NOTE: This mod does not alter normal operation.

Below are some examples of typical modifications. Contact the PTT manufacturer for more details if necessary.

Procedures For David Clark PTT

Unscrew the round black plastic cover from the jack.
Connect the joined black wires to the red wire.
Replace the round black plastic cover.

Procedures for Telex PT-200

Unscrew the round black plastic cover from the jack.
Cut the red wire in the middle of the wire.
Strip both ends of the insulation.
Solder the two ends to the ground lug to the PTT jack.
Replace the round black plastic cover.

Procedures for Telex PT-300

Unscrew the round black plastic cover from the plug jack.
Remove the heat shrink material from the joined black wires.
Solder these two wires to the lug that has a white wire already soldered to it.
Replace the round black plastic cover

Appendix B – PMA 8000 Installation Drawings

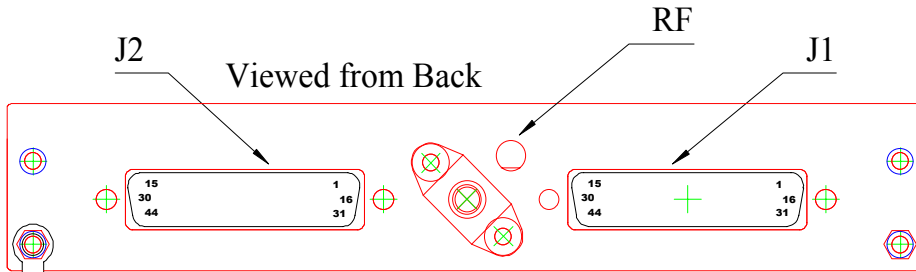
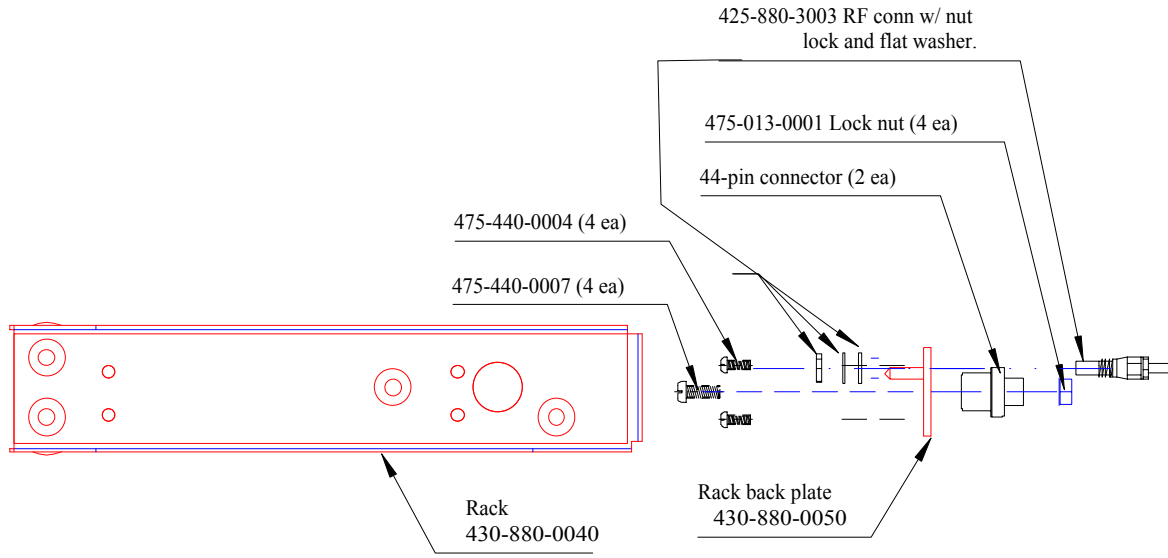

Solder Lug (mount as convenient)

Rear plate detail (not to scale)

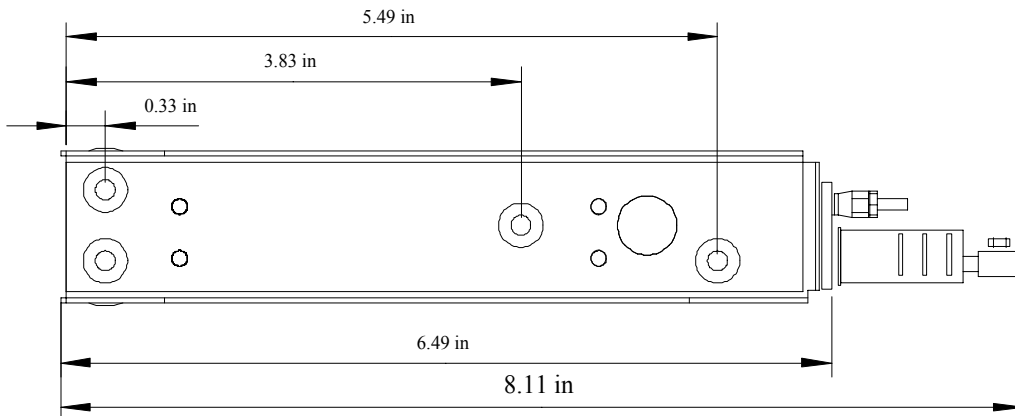
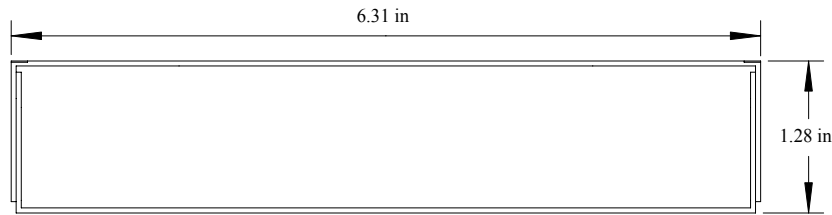
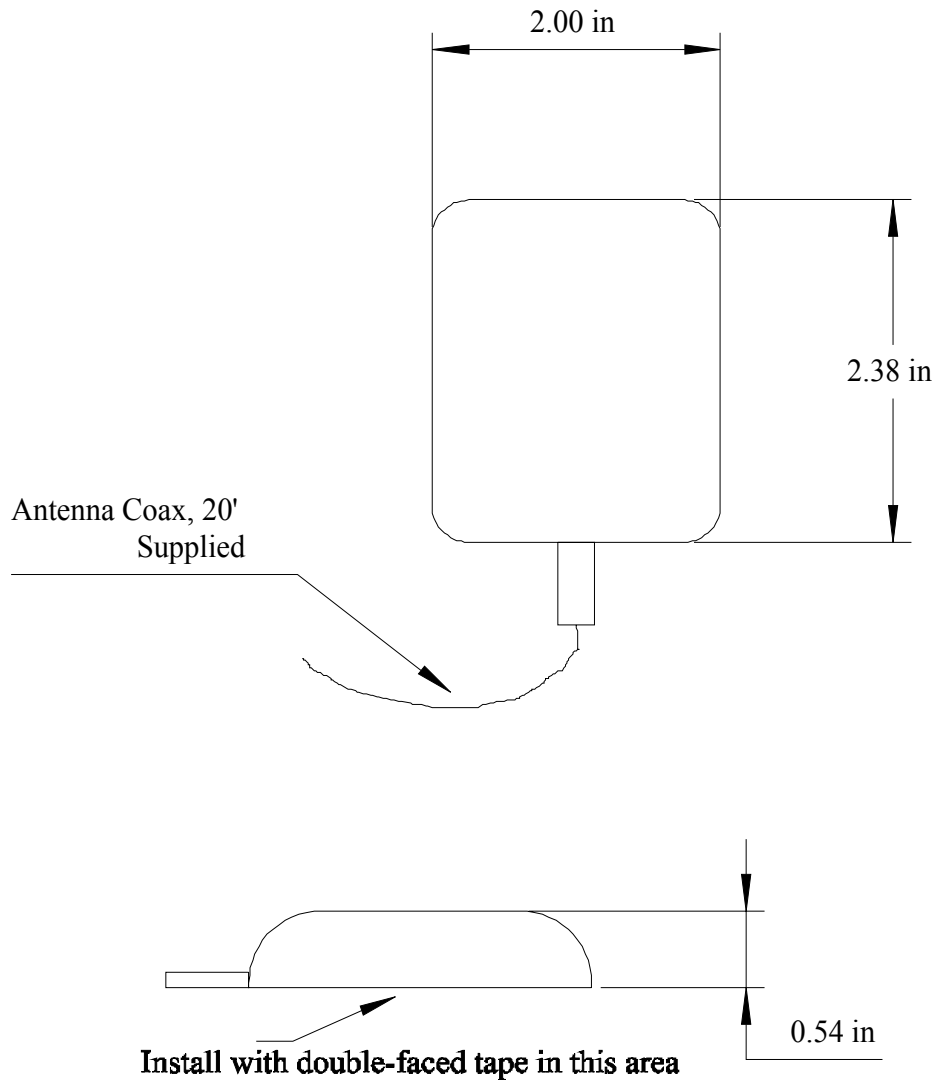

Figure 6-1 PMA8000-SR Installation Drawing

Caution: Apply steady pressure to the bezel while screwing the unit into the tray to ensure even seating of the unit and connectors.



Sirius Antenna 510-880-0100
wt. 3.0 Oz

Figure 6-2 SIRIUS Antenna Drawing

Appendix C, J1 Interconnect

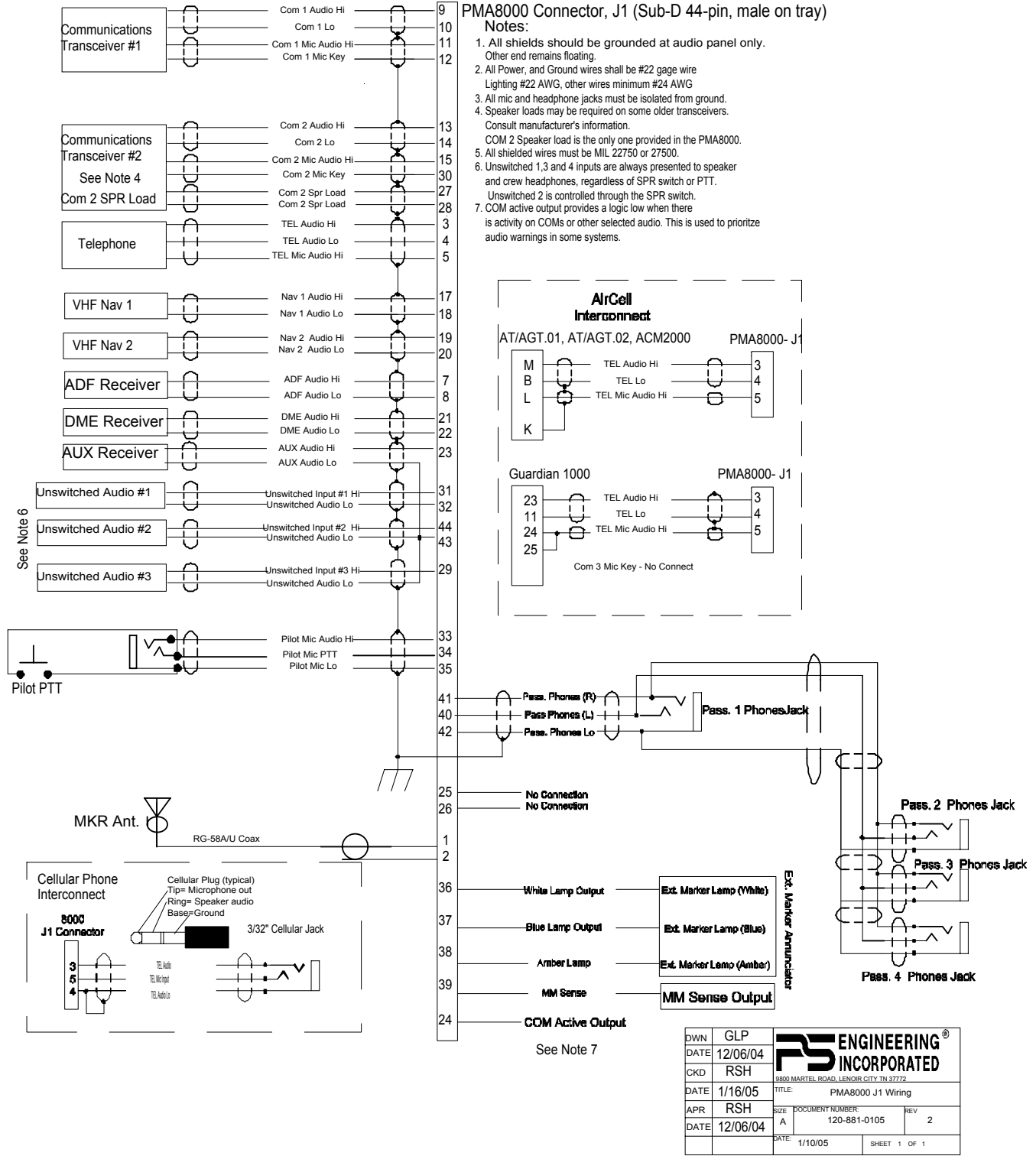

DWN	GLP	PS ENGINEERING INCORPORATED
DATE	12/06/04	
CKD	RSH	8800 MARTEL ROAD, LENOIR CITY, TN 37772
DATE	1/16/05	TITLE: PMA8000 J1 Wiring
APR	RSH	SIZE: DOCUMENT NUMBER: 120-881-0105
DATE	12/06/04	REV: 2
	DATE: 1/10/05	SHEET 1 OF 1

Appendix D, J2 Connector Interconnect

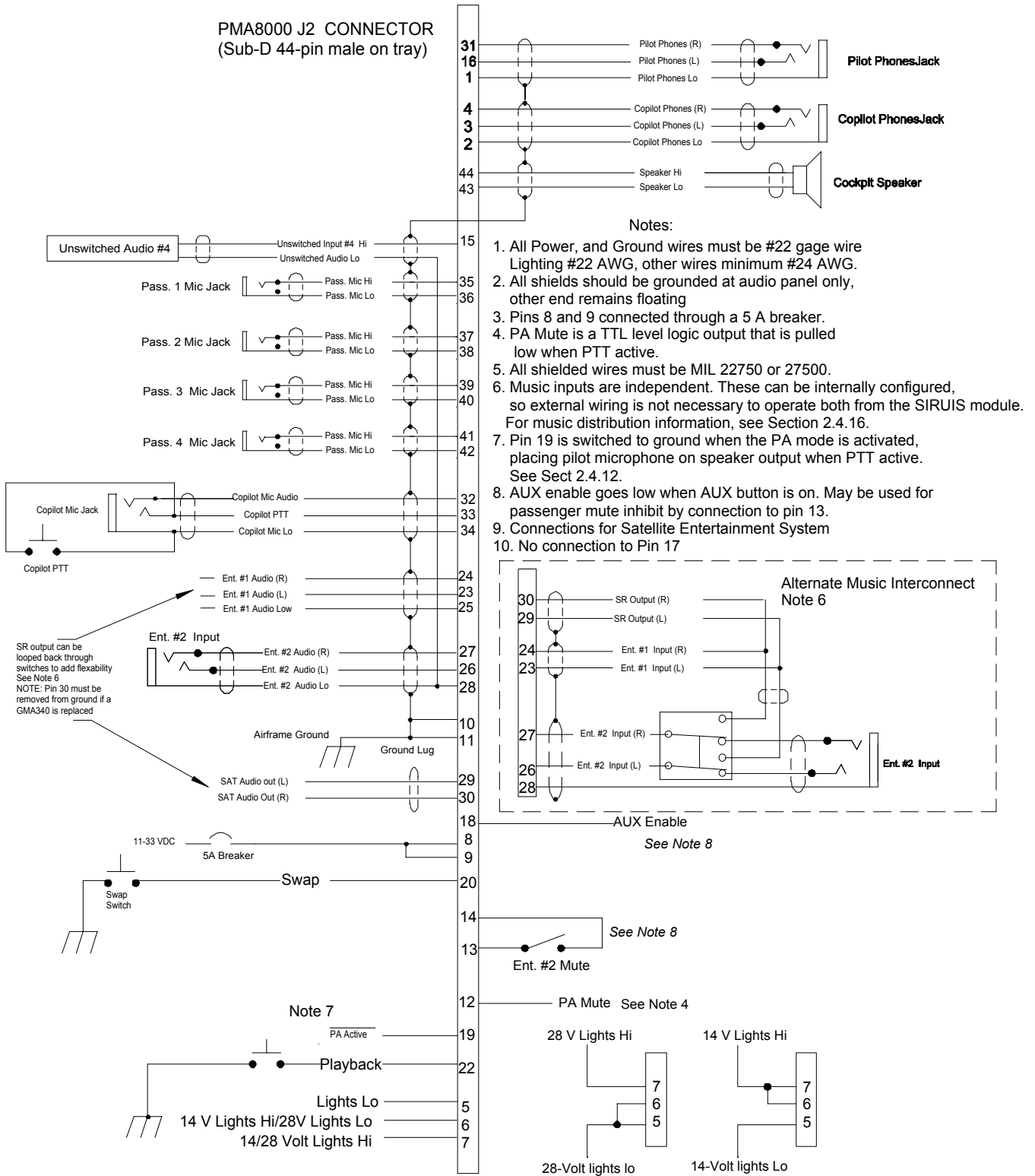

Appendix E- Instructions for FAA Form 337 and continuing airworthiness

9.1 Instructions for FAA Form 337, Audio Panels

One method of airworthiness approval is through an FAA Form 337, *Major Repair and Alteration (Airframe, Powerplant, Propeller, or Appliance)* In the case of the PMA8000-SR, you may use the following text as a guide.

Installed audio selector and 6-place intercom, PS Engineering PMA8000-SR, part number 050-**880**-(XXX) in (location) at station _____. Installed per *AC43.13-2, Chapter 2, paragraph 23* (Instrument Panel Mounting). Installed per PS Engineering *Installation Operators Manual* p/n 200-**880**-(XXXX), revision (), dated ().

These units are FAA-Approved under TSO C50c for audio amplifiers, and/or TSO C35d for Marker Beacon Receivers, and meets appropriate environmental qualifications outlined in RTCA DO-160D as appropriate or this aircraft.

Interface to existing aircraft radios in accordance with installation manual and in compliance with practices listed in *AC43.13-2, Chapter 2*. All wires are Mil-Spec 22759 or 27500. Connection to aircraft dimmer bus is _____. Power is supplied to the unit through a 3A circuit breaker (type and part number), and total electrical load does not exceed ____% of the electrical system capacity with the PMA8000-SR added.

Aircraft equipment list, weights and balance amended. Compass compensation checked. A copy of the operation instructions, contained in PS Engineering document 200-080-(), revision (), dated (), is placed in the aircraft records. All work accomplished listed on Work Order _____.

9.2 Instructions for Continuing Airworthiness, Audio System

Sample ICA Checklist for PS Engineering Audio System:

Section	Item	Information
1	Introduction	Installation of audio control panel with integrated marker beacon receiver and intercommunications system.
2	Description	Installation as described in manufacturer's installation manual referenced on FAA Form 337, including interface with other avionics audio as required.
3	Controls	See installation and operator's guide referenced on FAA Form 337.
4	Servicing	None Required
5	Maintenance Instructions	Unit: On Condition SIRIUS Antenna (510-880-0100) should be checked annually to ensure that it is attached to the glareshield, reapply tape if necessary
6	Troubleshooting	In the event of a unit problem, place the unit into "off," "fail-safe" and/or "emergency" mode. This allows pilot communications using COM 1. Follow checkout instructions in the installation manual referenced on the FAA Form 337. For a specific unit fault, contact the manufacturer at (865) 988-9800 for special instructions.
7	Removal and replacement information	<u>Removal:</u> Using a 3/32" Allen-head wrench, carefully unscrew the locking screw located in the center of the unit. While turning the wrench CCW, gently pull on the EDGES of the bezel until the unit is free from the mounting tray. <u>Installation:</u> Engage the locking screw at the back. Turn the locking screw CW, while applying slight pressure to the edges of the bezel. Do not over tighten!
8	Diagrams	Not applicable
9	Special Inspection Requirements	Not Applicable
10	Protective Treatments	Not Applicable
11	Structural Data	Not Applicable
12	Special Tools	None
13	Not Applicable	Not Applicable
14	Recommended Overhaul Periods	None
15	Airworthiness Limitations	Not Applicable
16	Revision	To be determined by installer

Appendix F RTCA DO160D Environmental Qualification Form

Audio Selector Panel/Intercom/Marker Beacon Receiver

Part Number: 050-880-()

FAA TSO Number: C50c, C35d

Manufacturer: PS Engineering Incorporated 9800 Martel Road Lenoir City TN 37772

Conditions	Section	Conducted Tests
Temperature and Altitude	4.0	Equipment tested to CAT A1 & D1
Low Temperature	4.5.1	-55° C Survival, -15°C Low Operating (A1)
High Temperature	4.5.2	+85°C Survival, +70°C High Short Time Operating
In-flight Loss of Cooling	4.5.4	Not Applicable, no cooling required
Altitude	4.6.1	50,000' unpressurized (D1)
Decompression	4.6.2	Not Applicable
Overpressure	4.6.3	Not Applicable
Temperature variation	5.2	Equipment tested to Category C
Humidity	6.0	Equipment tested to Category A
Shock	7.0	Equipment tested to Operational test only
Operational	7.2	Equipment tested to Operational test only
Crash Safety	7.3	Equipment tested to Operational test only
Vibration	8.0	Equipment tested to Category M & N
Explosion	9.0	Category X, not tested
Waterproofness	10.0	Category X, not tested
Fluids Susceptibility	11.0	Category X, not tested
Sand and Dust	12.0	Category X, not tested
Fungus	13.0	Category X, not tested
Salt Spray	14.0	Category X, not tested
Magnetic Effect	15.0	Equipment tested to Category Z
Power input	16.0	Equipment tested to Category B
Voltage Spike	17.0	Equipment tested to Category A
Audio Frequency Susceptibility	18.0	Equipment tested to Category B
Induced Frequency Susceptibility	19.0	Equipment tested to Category A
Radio Frequency Susceptibility	20.0	Equipment tested to Category T
Radio Frequency Emission	21.0	Equipment tested to Category B
Lightning Induced Transient Susceptibility	22.0	Equipment tested to Category XXE2
Lightning Direct Effects	23.0	Category X, not tested
Icing	24.0	Category X, not tested
ESD	25.0	Category X, not tested