

# PM3000 (11931) 4-Place Standard Intercom (Without Crew) Wiring Diagram

PM3000 Unit: DB-25 Male

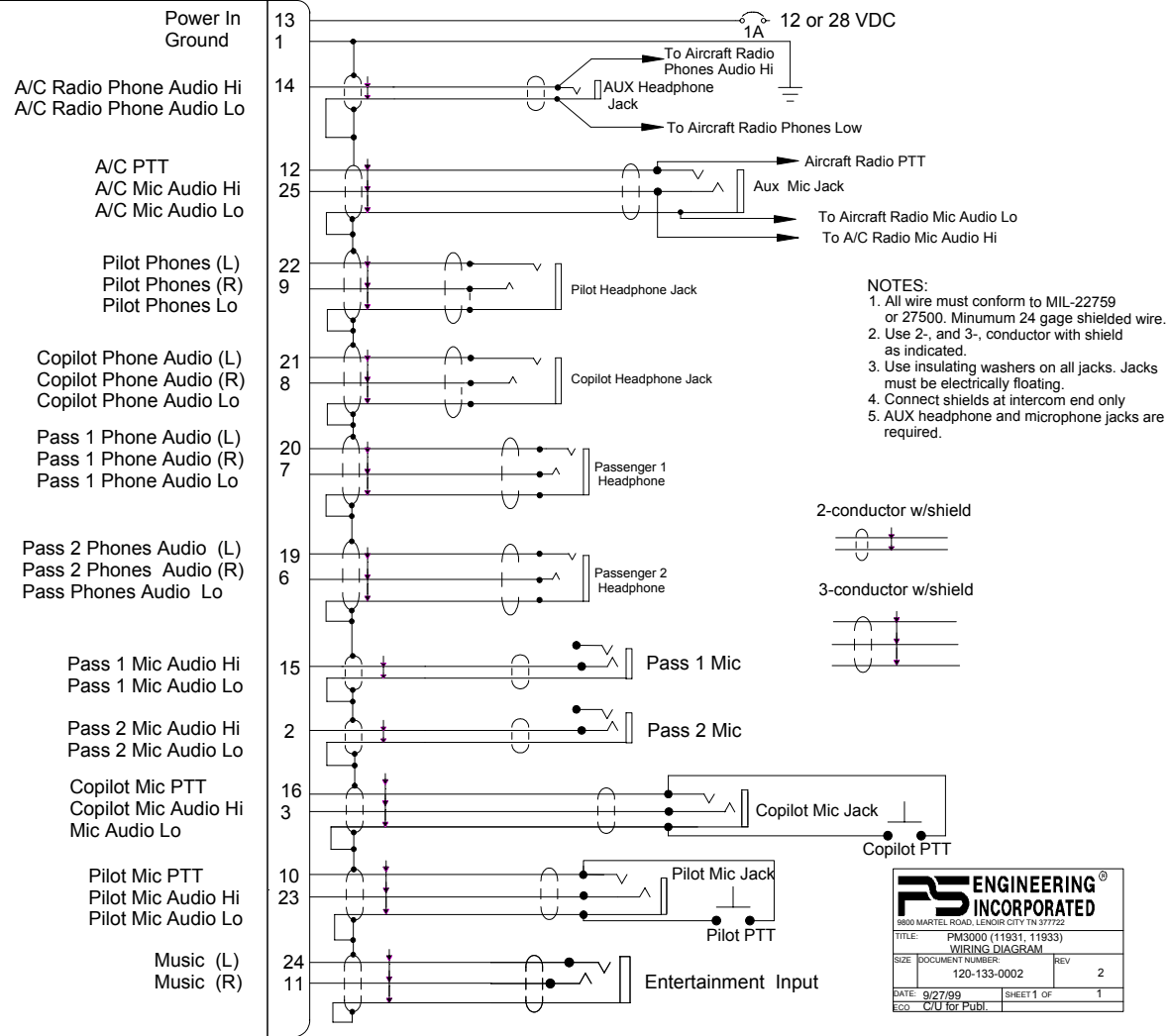

**PS ENGINEERING INCORPORATED**  
 9800 MARTEL ROAD, LENOIR CITY, TN 37722

TITLE:	PM3000 (11931, 11933)
SIZE:	WIRING DIAGRAM
DOC. NUMBER:	120-133-0002
REV:	2
DATE:	9/27/99
ECO:	C/U for Publ.
SHEET 1 OF	1

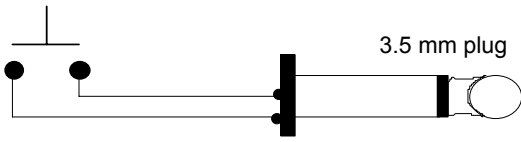

Recorder Playback Connection (11933, 19934)



9800 Martel Road  
 Lenoir City, TN 37722



**PM3000**  
 Part Number 11931: 4-Place Standard  
 and  
 Part Number 11932: 6-Place with CREW Function  
 High-fidelity Stereo Intercom System  
 Operation and Installation Manual

**FAA-TSO  
 C50c**

Also includes 11933, 11934, non-FAA TSO units

Document P/N 200-193-0004  
 Revision 4, Aug. 2003

PS Engineering, Inc. 2003 ©  
 Copyright Notice

Any reproduction or retransmittal of this publication, or any portion thereof, without the expressed written permission of PS Engineering, Inc. is strictly prohibited. For further information contact the Publications Manager at PS Engineering, Inc., 9800 Martel Road, Lenoir City, TN 37722. Phone (865) 988-9800

## Section I General Information

### 1.1 Introduction

The **PM3000** is an FAA-TSO approved, panel mounted, 4- to 6-place high-fidelity stereo intercom system (ICS). Please read this manual completely before installation to minimize the risk of damage to the unit and to become familiar with all the features.

### 1.2 Scope

This manual contains installation and operational instructions for the following PS Engineering unit:

Model	Description	Part Number
<b>PM3000</b>	Standard 4-place system	11931
<b>PM3000</b>	Crew Mode, 6-place system	11932
<b>PM3000</b>	4-place w/digital recorder (non-TSO)	11933
<b>PM3000</b>	6-place w/digital recorder (non-TSO)	11934

### 1.3 Description

The **PM3000** is a 4- or 6-place (depending on model), panel-mounted intercom with multiple volume and VOX (voice activated squelch) circuits using unified volume and squelch controls for the pilot, copilot and passengers.

With few controls for the pilot to use, the operation of the PM3000 is very straightforward. Yet the unit outperforms its much more complicated competition. Although there is only one volume control knob, when an adjustment is made to the volume control, all output amplifiers are being changed simultaneously. Likewise, when the squelch control knob is adjusted, several VOX circuits are being changed at the same time.

A mode switch allows the pilot to select different configurations. The "**ALL**" mode places all headsets on a party line. In the "**ISO**" mode, the

pilot is isolated from all others and is connected to the aircraft radio allowing un-interrupted radio communications.

The third mode, "**CREW**," included in part number 11932 (and 11934), allows the pilot and copilot to be separated from the passengers.

The PM3000 has an automatic fail-safe interconnect to the aircraft radios. If power is disrupted to the intercom for any reason, the pilot's headset is connected directly to the aircraft radio allowing continued radio communications.

A 2-color LED is green when power is on and changes to red when a Push to Talk (PTT or microphone key) is pressed.

Provision for entertainment input allows the pilot, copilot and passengers the option to listen to music during flight. During intercom or aircraft radio reception, this music will automatically mute to allow communications without distraction. When the activity ceases, the *SoftMute™* circuit gradually returns the music to the original listening volume. By depressing the "Mute" control (located on the Squelch knob) once, it is possible to have the music remain at a constant level, regardless of any ICS or radio traffic.

During various phases of flight, the degree of importance of the aircraft radio will vary. Because the "**ISO**" mode connects the pilot directly to the aircraft radio, select the "**ISO**" mode when the pilot must have top priority on radio transmissions.

Both pilot and copilot have transmit capabilities over the radio. The PM3000 only allows the voice of the person who presses their PTT to be transmitted over the aircraft radio. If both pilot and copilot press the PTT at the same time, the copilot will override. When either pilot or copilot presses PTT, all other microphones are disabled. The pilot can regain priority by switching the unit off.

## PM3000 (11932, 11934) w/Crew, 6-place wiring diagram

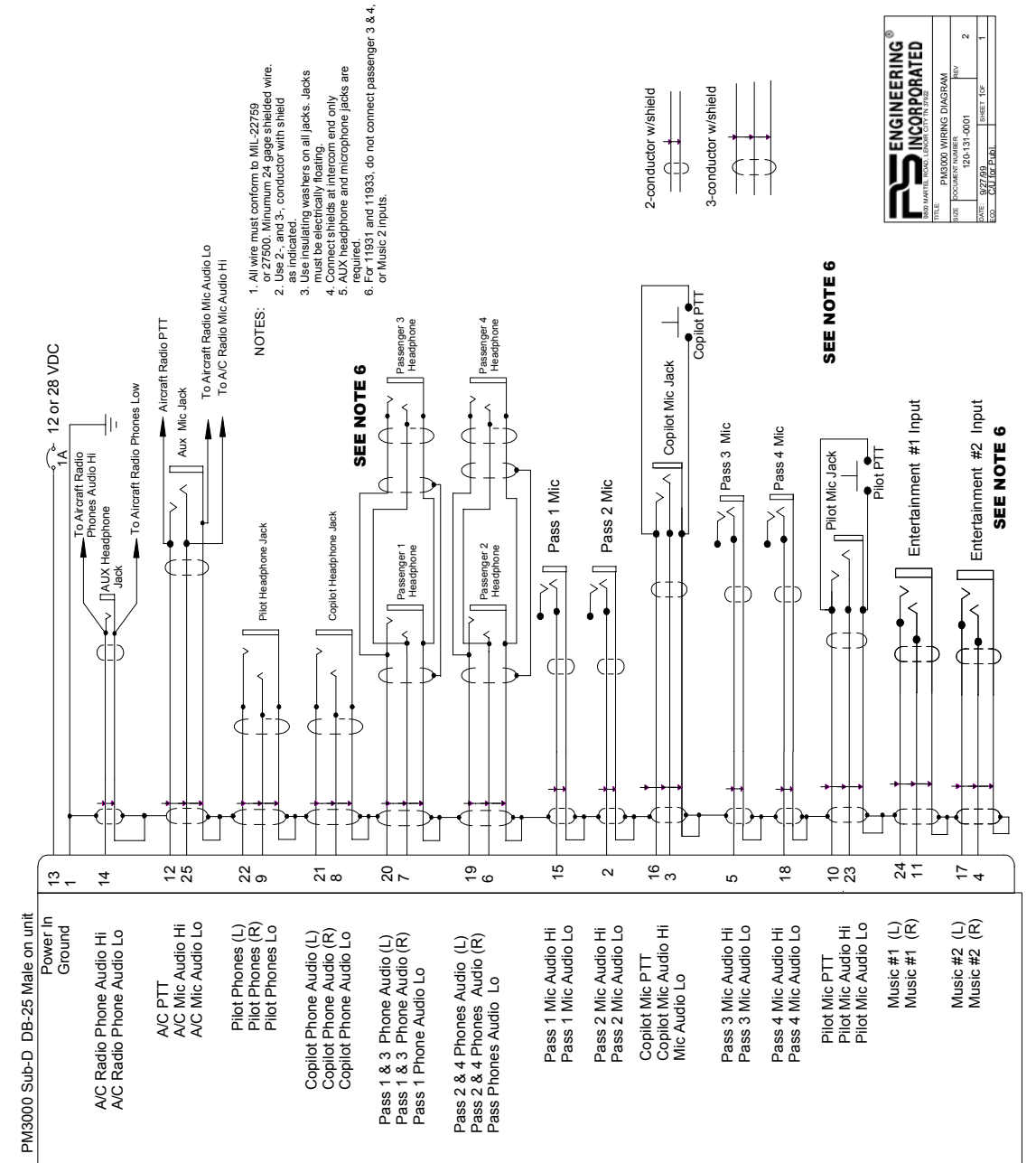

## Appendix B- Instructions for FAA Form 337

One method of airworthiness approval is through an FAA Form 337, *Major Repair and Alteration (Airframe, Powerplant, Propeller, or Appliance)* In the case of the PM3000, you may use the following text as a guide.

Installed x-place intercom, PS Engineering PM3000, part number 1193( ) in ( location ) at station \_\_\_ Installed per AC43.13-2, Chapter 2, paragraph 23 (Instrument Panel Mounting). Installed per PS Engineering *Installation Operators Manual* p/n 200-193-xxxx, revision x, dated ( ).

This unit is FAA-Approved under TSO C50c for audio amplifiers, and meets environmental tests outlined in RTCA DO-160C as appropriate or this aircraft.

Interface to existing aircraft radios in accordance with manufacturer's installation manual and in compliance with practices listed in AC43.13-2, Chapter 2. All wires are Mil-Spec 22759 or 27500. No connection to the aircraft dimmer bus is required. Power is supplied to the unit through a 1A circuit breaker ( type and part number ), and total electrical load does not exceed \_\_\_\_\_% of the electrical system capacity with the PM3000 added.

Aircraft equipment list, weight and balance amended. Compass compensation checked. A copy of the operation instructions, contained in PS Engineering document 200-193-xxxx, revision (x), ( date ), is placed in the aircraft records. All work accomplished listed on Work Order \_\_\_\_\_.

## Appendix C, Instructions for con-

## tinuing airworthiness

The PM3000 is considered an "on-condition" maintenance item. It is checked prior to each flight during normal operation. There are no additional considerations for continuing airworthiness other than the practices detailed in AC 43.13-1A, Chapter 15, Paragraph 750. This includes inspecting the unit to be sure it is securely fastened in its location, and that the wiring harness is not chafed or pinched, and remains secure. All panel jacks should be checked at each periodic inspection to ensure that they are tight and not in contact with other items behind the instrument panel.

## Appendix D Wiring Information

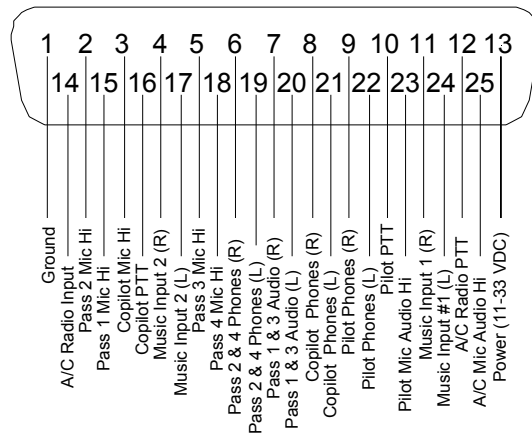

DB 25 Unit Connector

## 1.4 Approval Basis

The PM3000, part number 11931 or 11932, is FAA-approved under TSO-C50c, and RTCA, Inc. DO-214. Due to the fact that there is no TSO for the recorder function in the 11933 and 11934, these units are not fully TSO-approved. It is the responsibility of the installer to determine the approval basis for these units.

## 1.5 Specifications

Input power: 13.8 - 27.5 Volts DC  
Current Drain: < 200 mA (Externally fused at 1 Amp)

Headphone Impedance: 150-1000 Ω (typical)  
Audio Distortion: < 1.2% @ 50mW into 150 Ω load

Aircraft Radio Impedance: 1000 Ω (typical)  
Mic Frequency Response: ±3 dB, 350 Hz — 6000 Hz

Music Frequency Response: ±3 dB, 200 Hz – 15 kHz

Unit weight: 12 Ounces (0.34 kg)

Dimensions: 1.25" H x 3.00" W x 5.50" D  
(3.2 x 7.6 x 14.0 cm)

Environmental and technical qualifications:  
RTCA DO-160C/DO-214

A1D1/CA(MN)XXXXXZBBBBBTBKXX

Temperature: -20° to +55° C

## 1.6 Equipment required but not supplied

- Interconnecting cables as required (may be ordered from PS Engineering)
- Headphones, 150 Ω stereo, as required
- Microphones, general aviation, as required
- Interconnect wiring
- Crimping Tool, AMP (661966-1 or equiv.) and Positionerg 601966-5
- Circuit Breaker 1 Amp.

## Section II Installation

### 2.1 General Information

The PM3000 comes with all mounting hardware and jacks for installation. Installation of the PM3000, using the hardware supplied and available wiring does not require special tools or knowledge other than those used in the industry, and described in FAA Advisory Circular 43.13-2. It is the installer's responsibility to determine the approval basis for this installation. An FAA Form 337, or other approval may be required. See Appendix B for example of FAA Form 337.

### 2.2 Unpacking and preliminary inspection

The PM3000 was carefully inspected mechanically and thoroughly tested electronically before shipment. It should be free of electrical or cosmetic defect.

Upon receipt, verify that the parts kit includes the following:

#### PM3000 Installation Kits:

Part Number	Description	11931	11932	11933	11934
475-442-0002	#4-40 Machine screws, black	2	2	2	2
625-003-0001	Knobs (Soft Touch)	2	2	2	2
575-030-0001	PM3000 Faceplate (w/crew)		1		1
575-030-0003	PM3000 Faceplate (no crew)	1		1	
425-025-0010	25 pin Sub-D connector shell	1	1	1	1
425-020-5090	Crimp Sockets	25	25	25	25
625-025-0001	Connector hood	1	1	1	1
475-002-0002	Connector Thumbscrews	1	2	1	2
200-193-0003	Operator's and Installation Manual	1	1	1	1
122-001-0000	Drill Template	1	1	1	1
475-003-0002	Insulated Shoulder Washers	9	13	9	13
475-003-0001	Insulated Flat Washers	9	13	9	13
550-001-0002	Stereo Headphone Jack	4	6	4	6
550-001-0003	Microphone Jack	4	6	4	6
550-008-0001	Music Input Jack 1/8"	1	2	1	2
550-005-0001	IRS Plug (3.5 MM mono)			1	1

## 2.3 Equipment installation procedures

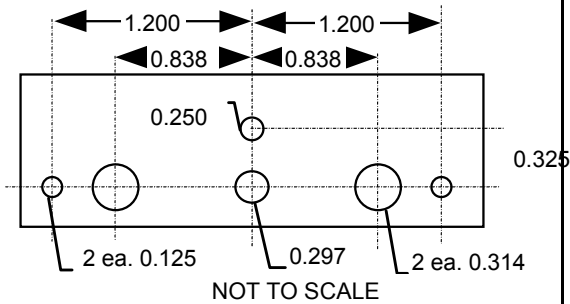

Figure 1 Hole Spacing

1. Using the template, drill six holes in the instrument panel in a location convenient to the pilot position(s).
2. Insert the **PM3000** from behind the instrument panel, aligning the holes for the knobs, LED, and switch.
3. Place the aluminum plate over the knob shafts and secure, using the two # 4-40 round head screws provided.
4. Install the knobs over the volume and squelch control shafts.
5. Complete a wiring harness in accordance with Appendix D.

## 2.4 Cable harness wiring

To complete the installation, a wire harness must be made as shown in Appendix D.

### Note:

PS Engineering can make a custom-tailored wiring harness for the installer. All harnesses use Mil-spec quality components with professional techniques, and are fully tested before shipment. Contact PS Engineering for more information, [www.ps-engineering.com](http://www.ps-engineering.com).

If the aircraft already has pilot headset jacks in-

stalled, you may re-use one mono set for the AUX (radio ) jacks but they should be moved to a new location to avoid confusion with the pilot's headphone jacks. In the event the intercom has to be removed for any reason, these jacks provide access to the aircraft radio system. Remove and discard copilot headset jacks if mono..

To connect intercom into the aircraft audio system, parallel the appropriate set of cables from the intercom to the Auxiliary Aircraft Radio Headset Jacks. Finally, install new pilot, copilot and passenger headset jacks into the aircraft and connect them directly to the appropriate pins of the **PM3000**. See the wiring diagram for all details of the wire harness interconnect.

## 2.4.1 Electrical Noise Issues

**WARNING:** You *must* use individual shielded cables for the microphone and headphone jacks. Combining these two wires **WILL** cause loud oscillations and degrade the intercom function. The oscillation is caused by the cross-coupling between the large headphone signal and the small microphone signal. The resulting feedback is a high-pitched squeal that varies with the volume control.

Due to the variety of the radio equipment found in today's general aviation aircraft, there is the potential for both radiated and conducted noise interference. The **PM3000** has a specially designed power supply to reduce conducted electrical noise on the power bus of the aircraft by at least 50dB. Although this is a very large amount of attenuation, it does not eliminate all noise when the amount is excessive. There must be at least 13.75 Volts DC present at the **PM3000** for the power supply to work within its optimum regulation. Otherwise, it will not be able to attenuate noise properly.

Shielding can protect the system from radiated noise (rotating beacon, electric gyros, switching power supplies, etc.). However, installation

Normally, any radio traffic or intercom conversation will mute the music heard in ALL mode, or for the front in CREW. However, when the crew desires uninterrupted music, the **PM3000** can be placed in the Karaoke Mode, for singing along. Press the right knob (squelch) once to activate Karaoke mode, so the music will not be muted. Press again to restore the SoftMute function.

## Section 4 Warranty and service

### 4.1 Warranty

In order for the factory warranty to be valid, the installations in a certified aircraft must be accomplished by an FAA-certified avionics shop and authorized PS Engineering dealer. If the unit is being installed by a non-certified individual in an experimental aircraft, a factory-made harness must be used for the warranty to be valid.

PS Engineering, Inc. warrants this product to be free from defect in material and workmanship for a period of one year from the date of installation. During this one-year warranty period, PS Engineering, Inc., at its option, will send a replacement unit at our expense if the unit should be determined to be defective after consultation with a factory technician.

This warranty is not transferable. Any implied warranties expire at the expiration date of this warranty. PS Engineering **SHALL NOT BE LIABLE FOR INCIDENTAL OR CONSEQUENTIAL DAMAGES**. This warranty does not cover a defect that has resulted from improper or unreasonable use or maintenance as determined by us. This warranty is void if there is any attempt to disassemble this product without factory authorization. This warranty gives you specific legal rights, and you may also have other rights, which may vary from state to state. Some states do not allow the exclusion of limitation of incidental or consequential damages, so the above

limitation or exclusions may not apply to you.

## 4.2 Factory Service

The **PM3000** is covered by a one-year limited warranty. See warranty information.

Call PS Engineering, Inc. at (865) 988-9800 before you return the unit. This will allow the service technician to provide any other suggestions for identifying the problem and recommend possible solutions.

Information is also available by visiting [www.ps-engineering.com/support.shtml](http://www.ps-engineering.com/support.shtml)

Units that arrive for repair without a method of payment will be returned via UPS COD.

After discussing the problem with the technician and you obtain a Return Authorization Number, ship product to:

**NOTE: PS engineering will not be responsible for any units sent by US Mail.**

PS Engineering, Inc.  
Service Department  
9800 Martel Road  
Lenoir City, TN 37772  
(865) 988-9800 FAX (865) 988-6619

## Appendix A — PTT Modifications

UN-MODIFIED P-T-T

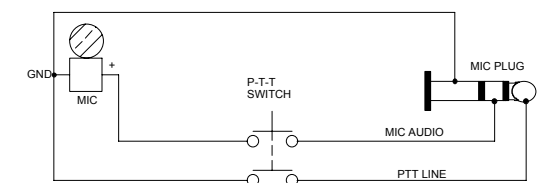

MODIFIED P-T-T

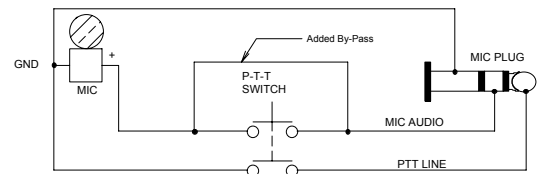

phone channels off (silent) while the pilot, copilot or passengers are not speaking. This reduces background noise from the aircraft. Only when someone speaks will their microphone turn on, allowing the audio to pass through the system. Although there is just one squelch control, there are actually three separate squelch threshold circuits. One circuit each for the pilot, copilot, and passengers. Only the microphone actually in use is open, reducing noise in the system.

With the engine running, set the squelch control knob by slowly rotating the squelch control knob clockwise until you no longer hear the background noise in the earphones. When the microphone is positioned properly near the lips, normal speech levels should open the channel. When you have stopped talking, there is a delay of about one half second before the channel closes. This prevents squelch closure between words, and helps eliminate choppy intercom conversations.

### 3.3 Mode Select

The center switch is a mode control that allows the pilot to tailor the intercom function to suit flight conditions. Regardless of configuration,

the pilot will always hear the aircraft radio.

NOTE: If there is a power failure to the **PM3000**, or if the power switch is turned off, the copilot will not hear the aircraft radio. Only the pilot is connected directly to the aircraft radio.

**ISO** (Up Position): The pilot is isolated from the intercom and is connected only to the aircraft radios. He will hear the aircraft radio reception (and sidetone during radio transmissions). Copilot and passengers will hear themselves and music but not the aircraft radio traffic.

**ALL** (Middle position): All parties will hear the aircraft radio, intercom, and music. However, during any ICS conversation, the music volume automatically mutes. The music volume increases gradually back to the original level after communications have been completed.

**CREW** (11932, 11934 only) (down position): Pilot and copilot positions will hear aircraft radio and music number one. Passengers will only hear other passenger's intercom, and music number 2. Music number two will not mute during intercom conversation.

### 3.4 Music Mute Control

Mode	Pilot Hears	Copilot Hears	Passenger Hears	Comments
<b>Isolate</b>	A/C Radio, Pilot Sidetone (during radio transmission)	Copilot and passenger intercom, Music #1	Passenger and Copilot intercom, Music #1	This mode allows the pilot to communicate with the ground without the copilot or passengers bothered by the conversations. Copilot and passengers continue to communicate and listen
<b>All</b>	Pilot, Copilot, A/C Radio, Passengers, Music #1	Copilot, Pilot, A/C Radio, Passengers, Music #1	Passengers, Pilot, Copilot, A/C Radio, Music #1	This mode allows all on board to hear radios as well as communicate on the intercom. Music and intercom is muted during intercom and radio communications
<b>Crew (11932 11934 only)</b>	Pilot, Copilot, A/C Radio Entertainment #1	Copilot, Pilot, A/C Radio Entertainment #1	Passengers, Entertainment #2	A second music source is automatically enabled for the passengers. Rear music not muted.

combinations can occur where minor interference is possible. The **PM3000** was designed in an interference -protected chassis and has internal filter capacitors on all input lines.

Ground loop noise occurs when there are two different return paths for the same signal, such as airframe and ground return wire. Large cyclic loads such as strobes, inverters, etc., can inject audible signals onto the airframe return path. Follow the wiring diagram very carefully to help insure a minimum of ground loop potential. Radiated signals can be a factor when low level microphone signals are bundled with current carrying power wires. Keep these cables separated.

Insulating washers are required on all microphone and headphone jacks to isolate them from aircraft ground. The use of a conductor instead of a shield for ground return eliminates these ground loop paths.

### 2.4.2 Power Requirements

The **PM3000** was designed to work with 12.8 to 27.5 volt DC negative ground systems. The **PM3000** must be externally protected with a one ampere (1A) circuit breaker or fuse.

### 2.4.3 Sidetone

The PM3000 can be modified to produce sidetone (hearing your voice during transmit), if the aircraft radios do not produce it. Contact the PS Engineering factory for details.

### 2.4.4 Entertainment Input

Stereo entertainment devices can be connected to the **PM3000**. Install 1/8" stereo jacks convenient the pilot and passengers to connect the entertainment devices into the system. PM3000, part number 11931 has a single entertainment input. The part number 11932 will accommodate two inputs, one for the crew, and another separate input that feeds the 4 passengers in

CREW mode.

It is possible to use only one entertainment device to provide music for both inputs in the 11932 system by connecting the output of the entertainment device in parallel to both the Music #1 and Music #2 inputs. We highly recommend, however, that you install a switch between the entertainment device and Music #1. This will give the pilot and copilot the ability to switch off music while in the CREW mode.

The music device will automatically mute when the ICS or aircraft radio becomes active. The Soft Mute™ feature slowly returns the music to full volume when the activity ceases. Pressing the Mute disable switch (located on the squelch control) in will inhibit this feature. Press again to reactivate SoftMute. Music #2 will never be muted during conversation and is heard only by the passengers while the intercom is in the Crew

Use only low level output of the entertainment devices to connect to the PM3000. Maximum signal level on the input is 3-volts peak-to-peak.  
**DO NOT USE SPEAKER OUTPUT LEVELS.**  
This will cause internal damage.

If speaker levels are to be used, install an Audio Link, p/n 101PL2, available from Crutchfield (1-800-955-3000).

**Local oscillators and other internal signals from CD or radio equipment can cause undesired interference with VHF navigation and communication equipment.**  
**Before takeoff, operate the entertainment device to determine if there is any adverse effect on aircraft systems. If any unusual operation is noted in flight, immediately switch the entertainment device off**

mode.

### 2.4.5 Passenger Volume Adjustment

The 6-place PM3000 (11932, 11934) has adjustments for passenger volume control. These are accessed through the left side of the unit (viewed from the front). There is a separate volume control for the left and right channels. The left adjustment is toward the front, and clockwise adjustment reduces passenger volume.

### 2.4.6 Internal Recorder (11933, 11934 only)

If the PM3000 unit is a part number 11933 or 11934 there is an internal recorder built into the unit. This stores the last 60 seconds of radio traffic. Only the pilot's position will hear the playback.

To use this function, a normally open (NO) momentary switch is connected to the 3.5 mm mono jack on the side of the unit. A low-current switch is recommended.

A radio signal of more than 1 VRMS is needed to trigger the IRS. Therefore, if the IRS does not seem to be recording, increase the aircraft radio volume slightly.

### 2.4.7 Monaural installations

The PM3000 can be installed as a monaural intercom. Connect the RIGHT channel to the headsets (this contains failsafe audio). Do NOT combine left and right headphone outputs.

### 2.4.8 External PTT hook-up

Part of the installation includes the installation of PTT (Push-to-Talk) switches that allow radio transmissions from pilot and copilot positions.

There are three configurations that can be used. You must select the case that best fits your installation. **NOTE:** Only the person who presses their PTT switch will be heard over the radio.

### CASE I-The PTT is built into the pilot and copilot yokes

Simply install the plugs from the headset into the aircraft headphone jacks. Then use the yoke mounted PTT to transmit. No other action is required.

### CASE -II Built in PTT only on the pilot side

This configuration requires a modified external PTT switch plugged into the copilot's mic jack. (See Appendix A) When the copilot's PTT is depressed, this activates an internal relay that switches the mic audio to the aircraft radio from the pilot to the copilot.

### Case III -No built in PTT switch at all.

Two built-in PTT must be installed or two external, modified PTT switches will be required for both the pilot and copilot. Modifications to the PTT may be required. (See Appendix A)

## 2.5 Post installation checkout

After wiring is complete, verify aircraft power is ONLY on pin 13 of the connector, and airframe ground on pin 1. Other voltages may be present on the incoming mic lines. Wiring errors can cause serious internal damage and void PS Engineering's warranty.

1. Apply power to the aircraft and avionics.
2. Plug headsets into the pilot, copilot and passenger positions.
3. Verify that the pilot position can transmit and receive with the **PM3000** in the OFF position (left hand knob controls on/off by push on-push off).
4. Push the volume knob to switch the **PM3000** on. Rotate the volume clockwise, about half way. Verify that the **Pwr/Xmt** light comes on green. If the LED is red, immediately switch off the

avionics, and troubleshoot the PTT installation.

5. Verify that the pilot can transmit and receive on the communications transceivers.
6. Verify proper intercom operation for pilot, copilot and passengers. For more information, consult Section 3.
7. Verify proper transmit and receive operation on the copilot position, noting that the copilot PTT switch allows proper transmission.
8. Verify proper Intercom system operation in the ALL, ISO (and CREW in part number 11932, 11934) modes.
9. Verify that the intercom system does not adversely affect any other aircraft system by systematically switching the unit on and off, while monitoring the other avionics and electrical equipment on the aircraft.

### Recorder Option:

Verify that the incoming radio signals are stored and played back using the external switch installed

## 3. Section III OPERATION

With the installation is complete, turn the **PM3000** on by pushing the volume control. This also engages the automatic fail-safe system. The



intercom volume control does not control the volume of the aircraft radio, allowing an additional degree of aircraft radio listening flexibil-



ity.

Figure 2 PM3000 (11931, 11933) front panel controls

Figure 3 PM3000 (11932, 11934) front panel controls

### 3.1 Adjusting the Volume

The **PM3000** volume control knob adjusts the loudness of the intercom and music only. The volume control on the **PM3000** does not affect the volume level of the aircraft radio. This allows the aircraft radio and intercom volume to be balanced independently. The volume control affects the music level for the pilot and copilot positions.

By turning the control clockwise, the audio level will increase. The **PM3000** has individual output amplifiers for each headset in the system and provides plenty of audio output power. **NOTE:** Volume level will not change with the number of headset installed.

Music # 2 passenger volume in CREW mode (11932 and 11934) version is a fixed level, and controlled locally by the headphone volume control or music device.

### 3.2 Adjusting the Squelch Control

This VOX operated intercom keeps all micro-