



9800 Martel Road  
Lenoir City, TN 37772  
[www.ps-engineering.com](http://www.ps-engineering.com)

## PAC45

**Special Mission Audio Controller System with  
MultiTalker® and IntelliVOX®**



Document P/N 200-045-0000

Rev. 21, July 2023

Audio Control System with MultiTalker Technology  
High-fidelity Stereo Intercom  
**System Installation and Operation Manual**  
FAA - TSO C139a  
Patented under one or more of the following;  
**No. 4,941,187; 5,903,227; 6,160,496 and 6,493,450, 7,391,877**

**In certified aircraft, warranty is not valid unless this product is installed by an  
Authorized PS Engineering dealer.**

**PS Engineering, Inc. 2023 ©**

*Copyright Notice*

Any reproduction or retransmittal of this publication, or any portion thereof, without the expressed written permission of PS Engineering, Inc. is strictly prohibited. For further information, contact the Publications Manager at PS Engineering, Inc., 9800 Martel Road, Lenoir City, TN 37772. Phone (865) 988-9800, email [contact@ps-engineering.com](mailto:contact@ps-engineering.com).

Table of Contents

|  |  |            |
|--|--|------------|
| <b>Section I – GENERAL INFORMATION .....</b> |  | <b>1-1</b> |
| 1.1  | INTRODUCTION .....   | 1-1        |
| 1.1.1  | LIMITATIONS .....  | 1-1        |
| 1.2  | SCOPE .....  | 1-1        |
| 1.3  | EQUIPMENT DESCRIPTION .....  | 1-3        |
| 1.4  | APPROVAL BASIS FAA TSO.....  | 1-3        |
| 1.1.2  | LIMITATIONS .....  | 1-3        |
| 1.5  | SPECIFICATIONS .....   | 1-4        |
| 1.6  | EQUIPMENT SUPPLIED.....  | 1-5        |
| 1.8  | CONFIGURATIONS .....   | 1-8        |
| 1.9  | LICENSE REQUIREMENTS.....  | 1-9        |
| <b>Section II - INSTALLATION .....</b>       |  | <b>2-1</b> |
| 2.1  | GENERAL INFORMATION.....   | 2-1        |
| 2.1.1  | SCOPE .....  | 2-1        |
| 2.1.2  | CERTIFICATION REQUIREMENTS.....                                      | 2-1        |
| 2.2  | UNPACKING AND PRELIMINARY INSPECTION.....                            | 2-1        |
| 2.3  | EQUIPMENT INSTALLATION PROCEDURES .....                              | 2-1        |
| 2.3.1  | COOLING REQUIREMENTS .....   | 2-1        |
| 2.3.2  | MOUNTING REQUIREMENTS.....   | 2-1        |
| 2.3.3  | AUDIO CONTROLLER CONNECTOR ASSEMBLY .....                            | 2-2        |
| 2.3.4  | THUMBSCREW AND SLIDE LOCK (AMS COMPLIANT) CONNECTOR ASSEMBLY.....    | 2-2        |
| 2.4  | CABLE HARNESS WIRING .....   | 2-3        |
| 2.4.1  | ELECTRICAL NOISE .....   | 2-3        |
| 2.4.2  | POWER .....  | 2-4        |
| 2.4.3  | AUDIO CONTROLLER INTERFACE.....                                      | 2-5        |
| 2.4.4  | TRANSMIT INTERLOCK .....   | 2-6        |
| 2.4.5  | BACKLIGHTING.....  | 2-6        |
| 2.4.6  | UNSWITCHED INPUTS.....   | 2-6        |
| 2.4.7  | COCKPIT VOICE RECORDER.....  | 2-6        |
| 2.4.8  | AUDIO ALERTS.....  | 2-7        |
| 2.4.9  | WIRED TELEPHONE/SATELLITE COMMUNICATION INPUT.....                   | 2-7        |
| 2.4.10                                       | MUSIC INPUT .....  | 2-8        |
| 2.4.11                                       | FACTORY-SET OPTIONS .....  | 2-8        |
| 2.5  | USER ADJUSTMENTS .....   | 2-11       |
| 2.5.1  | UNSWITCHED AUDIO LEVEL.....  | 2-11       |
| 2.5.2  | ADJUSTMENTS.....   | 2-11       |
| 2.5.3  | LOGIC SWITCH OPTIONS .....   | 2-13       |
| 2.6  | PAC45 PIN ASSIGNMENTS.....   | 2-15       |
| 2.7  | WIRING CHECKOUT.....   | 2-17       |
| 2.8  | OPERATIONAL CHECKOUT .....   | 2-17       |
| 2.8.1  | REQUIRED TEST EQUIPMENT .....  | 2-17       |
| 2.8.2  | AUDIO CONTROLLER TEST .....  | 2-17       |
| 2.8.3  | BLUETOOTH CHECKOUT.....  | 2-17       |
| 2.9  | FINAL INSPECTION.....  | 2-18       |
| <b>Section III OPERATION.....</b>            |  | <b>3-1</b> |
| 3.1  | SCOPE .....  | 3-1        |
| 3.2  | POWER AND FAIL SAFE .....  | 3-1        |
| 3.3  | COMMUNICATIONS TRANSMIT (XMT) SELECTION .....                        | 3-1        |
| 3.3.1  | SIMULCAST (MOD 4 ONLY) .....   | 3-2        |
| 3.4  | COM AUDIO SELECTOR.....  | 3-2        |
| 3.4.1  | MULTITALKER® HEAD RELATED TRANSFER FUNCTION (HRTF) .....             | 3-3        |
| 3.4.2  | HRTF On /Off .....   | 3-3        |
| 3.4.3  | AUDIO LOCATION .....   | 3-3        |
| 3.4.4  | RECEIVER ACTIVITY INDICATION (-RXI).....                             | 3-3        |
| 3.5  | NAVAID SELECTION .....   | 3-4        |
| 3.5.1  | TELEPHONE CONTROL.....   | 3-4        |
| 3.5.2  | SPEAKER CONTROL (PAC45 050-045-0002, HUB45R 050-045-0102 ONLY) ..... | 3-4        |

**PS Engineering**  
**PAC45 Audio Selector Panel and Intercom System**  
**Installation and Operator's Manual**

**3.6 INTERCOM OPERATION (8) ..... 3-4**

3.6.1 *INTELLIVOX*<sup>®</sup> INTERCOM VOX-SQUELCH..... 3-4

3.6.2 PUSH TO TALK INTERCOM (PTT ICS) ..... 3-5

3.6.3 INTERCOM VOLUME CONTROL..... 3-5

3.6.4 INTERCOM MODES ..... 3-6

**3.7 BLUETOOTH<sup>®</sup> CONNECTION..... 3-6**

3.7.1 PAIRING AND UNPAIRING BLUETOOTH DEVICES ..... 3-6

3.7.2 BLUETOOTH<sup>®</sup> TELEPHONE MODE ..... 3-6

3.7.3 MUSIC MUTING CONTROL (SERIAL NUMBER GH01139 AND ABOVE ONLY) ..... 3-7

**3.8 WIRED SATCOM/CELL PHONE INPUT ..... 3-7**

**3.9 DUAL CONTROL PANEL OPERATION/PILOT & COPILOT ..... 3-8**

**3.10 OBSERVER/MISSION CONTROL PANEL OPERATION ..... 3-9**

**3.11 ALERT AUDIO ..... 3-12**

3.11.1 STORING ALERT AUDIO ..... 3-12

**3.12 INTERCOM OPERATION BLOCK DIAGRAMS ..... 3-1**

3.12.1 SINGLE CONTROL PANEL..... 3-1

3.12.2 DUAL CONTROL HEAD, PILOT CTL45P AND COPILOT CTL45P ..... 3-1

3.12.3 DUAL CONTROL HEAD PILOT & COPILOT CTL45P PLUS OBSERVER CTL45M..... 3-3

3.12.4 THREE CONTROL HEAD, PILOT CTL45, COPILOT CTL45P AND MISSION OBSERVER CTL45M ..... 3-4

**Section IV – Warranty and Service .....4-1**

**4.1 WARRANTY..... 4-1**

**4.2 FACTORY SERVICE ..... 4-1**

**Appendix A – PAC45 Installation Drawings ..... A**

**Appendix B – Radio Interconnect Wiring ..... B**

**Appendix C – Intercom Interconnect Wiring ..... C**

**Appendix D – Control Head Interconnect Wiring ..... D**

**Appendix E, Unit Connector Wiring Reference ..... E**

9.1 J451 CONNECTIONS..... E

9.2 J452 CONNECTIONS..... E

9.3 J453 CONNECTIONS..... E

9.4 J454 CONNECTIONS..... E

**Appendix F – Instructions for FAA Form 337 and continuing airworthiness ..... F**

10.1 INSTRUCTIONS FOR FAA FORM 337, AUDIO CONTROLLERS ..... F

10.2 INSTRUCTIONS FOR CONTINUING AIRWORTHINESS, AUDIO SYSTEM ..... F

**Appendix G – RTCA DO160G Environmental Qualification Form ..... G**

11.1 MODEL NUMBER PAC45 AUDIO SELECTOR PANEL/INTERCOM REMOTE HUB..... G

11.2 MODEL NUMBER CTL45, AUDIO SELECTOR CONTROL PANEL ..... G

| Rev | Date          | Change  |
|-----|---------------|---|
| New | May 2017      | Initial Draft Manual  |
| 1   | June 2017     | Release for TSO Submittal   |
| 2   | July 2017     | Production-TSOA Release   |
| 3   | February 2018 | Change part number on 26-pin connector housing §1.6 Added PA PTT output (S/N Gxxxx and above)                 |
| 4   | June 2018     | Added detail on power consumption §1.5, clarification of DIP switch logic settings §2.5.3                     |
| 5   | August 2018   | Added Receive Indication Function (-RXI) and updated installation kits.<br>Correct PAX 5 & 6 connections      |
| 6   | November 2018 | Updated dimming adjustment (Configuration Level BBGAA and up)   |
| %7  | May 2019      | Re-designate transmit seats from Pass 1 & 2 to Observer 1 & 2 in wiring diagram Update §2.5.3.6 for DIP SW 10 |
| 8   | June 2019     | Update description of extra transmit seat (§2.4.3). Added part numbering detail (§1.6).                       |
| 9   | July 2019     | Corrected temperatures in §1.5  |
| 10  | July 2019     | Added SoftMute control (S/N GH01139 and above)  |
| 11  | October 2019  | Added Inverted CTL45  |
| 12  | February 2020 | Added Pull-Pull CTL45 Part Numbers  |
| 13  | April 2020    | Changed default alert audio, §2.4.8, added Simulcast (MOD 4), clarify ICS PTT operation                       |
| 14  | July 2020     | Changed installation kit connector hoods to metal.  |
| 15  | December 2020 | Update Factory Set Options list for MOD 7 §2.4.11   |
| 16  | April 2021    | Clarify Serial and Audio Grounds §2.6   |
| 17  | February 2022 | Clarify the dimmer adjustment steps in §2.5.2.2   |
| 18  | March 2022    | Add additional configuration switches §2.4.11   |
| 19  | October 2022  | Update dimmer adjustments to improve NVG Day/Night performance <a href="#">§2.5.2</a> (S/N MH01281 and above) |
| 20  | February 2023 | Added Dual audio systems configuration (MOD 10)   |
| 21  | July 2023     | Extent Temperature Qualification  |

## Section I – GENERAL INFORMATION

### 1.1 INTRODUCTION

The PAC45 represents a revolutionary step in cockpit audio control and intercommunications utility. MultiTalker®, using licensed U.S. Air Force patented technology, provides True Dimensional Sound, helping pilots to more easily discern from simultaneous radio receptions. Our patented *IntelliVOX*® design, programmable MultiTalker® and alert configurations, marks this panel as the next level of audio control. The unit is designed for outstanding ergonomics and visually defined mode annunciation and selection.

Before installing and/or using this product, please read this manual completely. This will ensure that you will take full advantage of all the advanced features in the PAC45.

#### 1.1.1 Limitations

This article meets the minimum performance and quality control standards required by a technical standard order (TSO). Installation of this article requires separate approval. Refer to Advisory Circular 20-41A for information on TSO installation approval.

Operation is subject to the following conditions:

- This device may not cause harmful interference.
- This device must accept any interference received, including interference that may cause undesired operation.

### 1.2 SCOPE

This manual provides detailed installation and operation instructions for the PS Engineering PAC45-series of Audio Selector Panel/Intercom Systems. This includes the following units:

| Model number                           | Description  | PS Engineering Part Number | NVIS Compatible Part Number |
|--|--|----------------------------|-----------------------------|
| PAC45<br><i>One Touch Switches</i>     | Panel-mounted Audio Control System with dual CVR outputs, includes integrated control head (OTS Push-Push) and Audio Hub, with standard bezel label, includes install kit 250-045-0100, qty. 2, 26 pin connectors.           | 050-045-0001               | 050-045-6001                |
| PAC45<br><i>One Touch Switches</i>     | Panel-mounted Audio Control System with single CVR and speaker out, includes integrated control head (OTS Push-Push) and Audio Hub, with standard bezel label, includes install kit 250-045-0100, qty. 2, 26 pin connectors. | 050-045-0002               | 050-045-6002                |
| PAC45 INV<br><i>One Touch Switches</i> | Same as above -0001, but with inverted CTL45 (OTS Push-Push)   | 050-045-0003               | 050-045-6003                |
| PAC45 INV<br><i>One Touch Switches</i> | Same as above -0002, but with inverted CTL45 (OTS Push-Push)   | 050-045-0004               | 050-045-6004                |

**PS Engineering**  
PAC45 Audio Selector Panel and Intercom System  
Installation and Operator's Manual

| <b>Model number</b>                 | <b>Description</b>   | <b>PS Engineering Part Number</b> | <b>NVIS Compatible Part Number</b> |
|-------------------------------------|--|-----------------------------------|------------------------------------|
| PAC45                               | Panel-mounted Audio Control System with dual CVR outputs, includes integrated control head (Push-Pull) and Audio Hub, with standard bezel label, includes install kit 250-045-0100, qty. 2, 26 pin connectors.           | 050-045-0007                      | 050-045-6007                       |
| PAC45                               | Panel-mounted Audio Control System with single CVR and speaker out, includes integrated control head (Push-Pull) and Audio Hub, with standard bezel label, includes install kit 250-045-0100, qty. 2, 26 pin connectors. | 050-045-0008                      | 050-045-6008                       |
| PAC45 INV                           | Same as above -0007, but with inverted CTL45 (Push-Pull)   | 050-045-0009                      | 050-045-6009                       |
| PAC45 INV                           | Same as above -0008, but with inverted CTL45 (Push-Pull)   | 050-045-0010                      | 050-045-6010                       |
| HUB45R                              | Remote-mounted Audio Hub for analog I/O and processing with dual CVR   | 050-045-0100                      | N/A                                |
| HUB45R                              | Remote-mounted Audio Hub for analog I/O and processing with single CVR and speaker out   | 050-045-0102                      | N/A                                |
|                                     |  |                                   |                                    |
| HUB45R                              | Same as above -0102, with dual CVR w/external Bluetooth antenna  | 050-045-0104                      | N/A                                |
| HUB45R                              | Remote mounted Audio Hub w/speaker and External Bluetooth antenna  | 050-045-0105                      | N/A                                |
| CTL45P<br><i>One Touch Switches</i> | Panel Mounted Control Head for Flight Crew (OTS Push-Push)   | 050-045-02XX*                     | 050-045-62XX*                      |
| CTL45P<br><i>One Touch Switches</i> | Panel Mounted Control Head for Flight Crew – Inverted (OTS Push-Push)  | 050-045-12XX*                     | 050-045-64XX*                      |
| CTL45M<br><i>One Touch Switches</i> | Panel-mounted Control Head for Mission Personnel (OTS Push-Push)   | 050-045-03XX*                     | 050-045-63XX*                      |
| CTL45M<br><i>One Touch Switches</i> | Panel-mounted Control Head for Mission Personnel (OTS Push-Push)   | 050-045-13XX*                     | 050-045-65XX*                      |
| CTL45P                              | Panel Mounted Control Head for Flight Crew (Pull – Push)   | 050-045-30XX*                     | 050-045-7XXX*                      |
| CTL45P INV                          | Panel Mounted Control Head for Flight Crew- Inverted (Pull – Push)   | 050-045-35XX*                     | 050-045-75XX*                      |
| CTL45M                              | Panel Mounted Control Head for Mission Personnel (Pull – Push)   | 050-045-50XX*                     | 050-045-8XXX*                      |
| CTL45M INV                          | Panel Mounted Control Head for Mission Personnel (Pull – Push)   | 050-045-55XX*                     | 050-045-85XX*                      |

| Model number  | Description   | PS Engineering Part Number | NVIS Compatible Part Number |
|---|---|----------------------------|-----------------------------|
| PAC45 Op-tional Install Kit   | For installations that are not replacing "third party" audio controllers, includes 50 & 37 pin connectors/hardware. | 250-945-0750               |                             |
| Label45   | Customizable bezel label program  | 575-145-XXXX               |                             |
| *The exact CTL45 part number depends upon the nomenclature applied to the bezel label. Consult PS Engineering for specific LRU part number. |   |                            |                             |
| OTS = <i>One-Touch-Switches</i> (Push-Push)   |   |                            |                             |

### 1.3 EQUIPMENT DESCRIPTION

The PAC45 is a state-of-the-art audio isolation amplifier and audio selector that contains an automatic voice activated (VOX) intercom system. It can switch six transceivers (Com 1 - 6) and six receivers (Nav 1, Nav 2, MKR, and three additional inputs that can be individually labeled, for use with ADF, DME, AUX, etc.).

There are four unswitched inputs, available for traffic or EGPWS, autopilot disconnect, and/or radar altimeter warning.

A wired input is available for Satellite or Cellular telephone.

In addition, three field programmable alerts can be triggered by external sources to provide additional capability.

The individual volume controls select the receiver audio source provided to the headphones when selected to the "out" position.

An eight-station voice activated (VOX) intercom is included in the PAC45. This system has PS Engineering's patented *IntelliVOX*® circuitry that eliminates manual adjustments. The intercom system incorporates pilot isolate, all and crew modes, a stereo music input with "SoftMute™".

In the PAC45, a Bluetooth® wireless interface is available for wireless telephone and music connection.

CTL45 Control Heads are available with the control layout inverted. This makes it easier to see the legend in certain installation orientations.



**Figure 1-1 Standard and Inverted CTL45**

### 1.4 APPROVAL BASIS FAA TSO

**FAA TSO** The PAC45-series Audio Selector Panels is FAA authorized under TSO C139A (Audio Amplifiers), ED-14C/DO-160G (*Environmental Conditions and Test Procedures for Airborne Equipment*), ED12B/DO-178C, Level D (*Software Considerations for Airborne Equipment*) and ED-18/DO-214A (*Audio Systems Characteristics and Minimum Operational Performance Standards for Aircraft Audio Systems*).

#### 1.1.2 Limitations

This article meets the minimum performance and quality control standards required by a technical standard order (TSO). Installation of this article requires separate approval.

Refer to Advisory Circular 20-41A for information on TSO installation approval.

Operation is subject to the following conditions:

This device may not cause harmful interference.

This device must accept any interference received, including interference that may cause undesired operation.

## 1.5 SPECIFICATIONS

| <b>TSO COMPLIANCE</b>                |  |
|--------------------------------------|--|
| <i>Audio Selector/Intercom:</i>      | FAA TSO-C139A  |
| <b>APPLICABLE DOCUMENTS:</b>         | RTCA/DO-214A<br>RTCA/DO-160G<br>RTCA/DO-178C   |
| <b>ENVIRONMENTAL Qualifications:</b> | A1D1BABSXXXXXZBABZATTMA3J33XXA   |
| <i>Temperature Range:</i>            | HUB45<br>CTL45   |
| Operating:                           | -45° C to +55°C      -45° C to +70°C   |
| Short Term Operating:                | -45° C to +70°C      -45° C to +70°C   |
| Survival:                            | -55° C to +85°C      -55° C to +85°C   |
| <i>Altitude:</i>                     | Up to 55,000 feet in a non-pressurized area of the cockpit.  |
| <b>DIMENSIONS:</b>                   | Height: 1.9 in. (4.8 cm) Width: 5.75 in. (14.6 cm)<br>Depth behind panel (PAC45): 7.38 in. (18.75 cm) including connectors |
| <b>UNIT WEIGHT</b>                   |  |
| PAC45 -001                           | 2.0 lb. (0.90 kg)  |
| HUB45                                | 1.0. (.45 kg)  |
| CTL45                                | 1.0. (.45 kg)  |
| <b>POWER REQUIREMENTS:</b>           |  |
| <i>Voltage:</i>                      | 18 to 33 VDC   |
| <i>Maximum Current:</i>              | 0.5 Amp (Externally protected by a 1 Amp circuit breaker.)   |
| <i>Typical</i>                       | PAC45 (Hub + CTL mated): 500mA   |
| <i>Alert Power</i>                   | HUB45 only 350 mA  |
| <i>Lighting</i>                      | 10 mA<br>CTL45 only: 150 mA<br>< 5mA   |

**PS Engineering**  
PAC45 Audio Selector Panel and Intercom System  
Installation and Operator's Manual

| <b>Audio Selector Specifications</b>           |   |
|--|---|
| <i>Audio selector panel input impedance:</i>   | 510 Ω   |
| <i>Input Isolation:</i>                        | -60 dB (min.)   |
| <i>Switched Receiver Inputs:</i>               | 11 (COM 1– COM 6, TEL, NAV 1, NAV 2, Marker, ADF)(Can be relabeled as desired)            |
| <i>Unswitched Inputs:</i>                      | 4   |
| <i>Transmitter Selections:</i>                 | 7 (COM 1, COM 2, COM 3, COM 4, COM 5, COM 6 plus Telephone) (Can be relabeled as desired) |
| <i>Headphone Impedance:</i>                    | 150 – 1000 Ω  |
| <i>Headphone Output:</i>                       | 200 mW into 150Ω each side (left and right) headset, no clipping <.5% THD typical         |
| <i>Speaker Output (-0002 &amp; -0102 only)</i> | 3 V <sub>rms</sub> Maximum  |
| <i>Microphone Impedance:</i>                   | 150 - 600 Ω   |
| <i>PA Output</i>                               | 1 V <sub>rms</sub> into 500 Ω   |
| <i>Bluetooth Radio</i>                         | Class 3, FCC ID QOQWT32AI   |
| <b>Intercom Specifications</b>                 |   |
| <i>Intercom Positions:</i>                     | Up to 8 places (with individual <i>IntelliVOX</i> ® circuits)                             |
| <i>Music Inputs:</i>                           | 1 (Stereo) plus Bluetooth   |
| <i>Music Muting:</i>                           | >-30 dB "Soft Mute" when Com or intercom active.  |
| <i>Distortion:</i>                             | <1% THD @ 200 mW into 150 Ω   |
| <i>Mic Freq. Response, 3 dB:</i>               | 300 Hz - 6000 Hz  |
| <i>Stereo Music Freq. Response, 3 dB:</i>      | 20 Hz – 16 kHz  |

## 1.6 EQUIPMENT SUPPLIED

The following units comprise the PAC45 System:

| Model  | Description   | Standard Part Number | NVIS Compatible Part Number |
|--------|---|----------------------|-----------------------------|
| PAC45  | Single Panel-mounted System (HUB45 and CTL45P)                            | 050-045-000X         | 050-045-600X                |
| or     |   |                      |                             |
| HUB45R | Remote-mounted Audio Hub for analog I/O and processing                    | 050-045-010X         | N/A                         |
| CTL45P | Panel Mounted Control Head for Flight Crew (Push – Push)                  | 050-045-02XX*        | 050-045-62XX*               |
| CTL45P | Panel Mounted Control Head for Flight Crew – Inverted (Pull – Push)       | 050-045-12XX*        | 050-045-64XX*               |
| CTL45P | Panel Mounted Control Head for Flight Crew (Pull – Push-)                 | 050-045-30XX*        | 050-045-7XXX*               |
| CTL45M | Panel-mounted Control Head for Mission Personnel (Push – Push)            | 050-045-03XX*        | 050-045-63XX*               |
| CTL45M | Panel-mounted Control Head for Mission Personnel – Inverted (Pull – Push) | 050-045-55XX*        | 050-045-8XXX*               |
| CTL45M | Panel-mounted Control Head for Mission Personnel (Pull – Push)            | 050-045-5XXX*        | 050-045-8XXX*               |
| CTL45M | Panel-mounted Control Head for Mission Personnel Inverted                 | 050-045-1300*        | 050-045-6700*               |

. \*The part numbers shown are for “Standard” bezel label nomenclature. Custom bezel nomenclature is available, using the custom configuration program at: [http://www.ps-engineering.com/PAC45\\_custom\\_legend.shtml](http://www.ps-engineering.com/PAC45_custom_legend.shtml)



**PS Engineering**  
PAC45 Audio Selector Panel and Intercom System  
Installation and Operator's Manual

PAC45 Standard Installation Kit 250-945-0750 (37 & 50 Pin)

| Description                        | PSE Part Number | Qty. | Manufacturer    | MFR Part Number |
|------------------------------------|-----------------|------|-----------------|-----------------|
| 50 pin connector hood              | 625-050-0967    | 1    | Harting         | 09 67 050 0343  |
| 37 pin connector hood              | 625-037-3703    | 1    | Harting         | 09 67 037 0343  |
| Standard Density Female Sockets    | 425-020-5090    | 50   | Deutsch         | M39029/63-368   |
| 50 Pin Female Conn, Housing        | 425-050-0967    | 1    | Harting         | 09 67 050 4701  |
| 37 Pin Female Kit Connector w/Pins | 425-037-1757    | 1    | TE Connectivity | 1757820-9       |

PAC45 Retrofit Installation Kit: 250-045-0100

| Description                 | PS E Part Number | Quantity | Manufacturer     | MFR Part Number |
|-----------------------------|------------------|----------|------------------|-----------------|
| D-Sub housing 9 pin female  | 425-009-7709     | 1        | Amphenol         | L177-RR-E-09-S  |
| D-sub Pins Male             | 425-020-5089     | 9        | Deutsch          | M39029/64-369   |
| D-sub Pins Female           | 425-020-5090     | 9        | Deutsch          | M39029/63-368   |
| D-Sub housing 26 pin female | 425-026-1800     | 2        | NorComp          | 180-026-273L000 |
| Socket contact 22-28 AWG    | 425-030-7354     | 52       | Amphenol         | M39029/57-354   |
| D-Sub Latch slide clip      | 475-045-5206     | 4        | Tyco Electronics | 5206942-1       |
| Hood DB9                    | 625-009-5750     | 1        | Tyco Electronics | 5750100-1       |
| Hood DB26                   | 625-015-5206     | 2        | Tyco Electronics | 5206478-2       |

HUB45R Remote Hub Retrofit Installation Kit: 250-045-0250

| Description              | PS E Part Number | Qty. | Manufacturer | MFR Part Number |
|--------------------------|------------------|------|--------------|-----------------|
| D-Sub housing 9 pin male | 425-009-0777     | 1    | Amphenol     | L777-RR-E-09-P  |
| D-Sub Pins Male          | 425-020-5089     | 9    | Deutsch      | M39029/64-369   |
| Hood DB9                 | 625-009-9034     | 1    | Harting      | 09 67 009 0348  |

HUB45 Installation Kit 250-945-0200

| Description              | PS E Part Number | Qty. | Manufacturer | MFR Part Number |
|--------------------------|------------------|------|--------------|-----------------|
| 15/26 pin connector hood | 625-015-1503     | 2    | Harting      | 09 67 015 0348  |
| DB26 Female Connector HD | 425-026-1800     | 2    | NorComp      | 180-026-273L000 |
| Female Socket            | 425-030-7354     | 52   | Amphenol     | M39029/57-354   |
| Slide Lock Post*         | 475-045-6514     | 4    | TE           | 5206514-6       |

\*See §2.3.4

Supplied with HUB45R with remote Bluetooth antenna:

| Description   | PS E Part Number | Qty | Manufacturer | MFR Part Number |
|---|------------------|-----|--------------|-----------------|
| SMA Straight Plug RG-174/U 36-Bluetooth Antenna Cable | 300-045-1351     | 1   | Amphenol     | 135110-02-36.00 |
| Antenna Bluetooth 2.4GHz Right Angle                  | 510-045-9602     | 1   | Taoglas      | GW.26.0112.HT   |

**PS Engineering**  
PAC45 Audio Selector Panel and Intercom System  
Installation and Operator's Manual

**Remote Mount HUB45R retrofit Installation Kit 250-045-0300**

| Description                                      | PS E Part Number | Qty. | Manufacturer   | MFR Part Number |
|--|------------------|------|----------------|-----------------|
| 9-Pin Male D-Sub Housing                         | 425-009-0777     | 1    | Amphenol       | L777-RR-E-09-P  |
| D-Sub male pins                                  | 425-020-5089     | 9    | Deutsch        | M39029/64-369   |
| 9-Pin D-Sub Female Housing                       | 425-009-7709     | 1    | Amphenol       | L777-RR-E-09-S  |
| D-Sub Female sockets                             | 425-020-5090     | 9    | Deutsch        | M39029/64-368   |
| Remote Mounting Flange LEFT                      | 430-045-0120     | 1    | PS Engineering |                 |
| Remote Mounting Flange RIGHT                     | 430-045-0125     | 1    | PS Engineering |                 |
| 4-40 x 3/16" Phil-Pan w/EXT Star Washer          | 475-440-0500     | 8    |                |                 |
| 4-40 x 3/16" Phil-Flat Gold + Patch Counter Sunk | 475-442-2001     | 12   |                |                 |
| Connector Hood DB9                               | 625-009-9034     | 1    | Harting        | 09 67 009 0348  |

**CTL45 Installation Kit 250-043-0200**

| Description                  | PS E Part Number | Qty. | Manufacturer | MFR Part Number |
|------------------------------|------------------|------|--------------|-----------------|
| Connector Hood DB9           | 625-009-9034     | 1    | Harting      | 09670090348     |
| Connector Female Shell DB9   | 425-009-7709     | 1    | Amphenol     | L777-RR-E-09-S  |
| Standard Density Female Pins | 425-020-5090     | 9    | Deutsch      | M39029/64-368   |

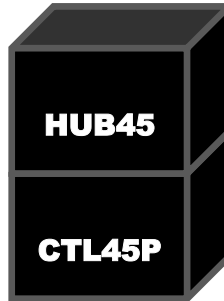
**EQUIPMENT REQUIRED BUT NOT SUPPLIED**

- a. Circuit Breakers: 1 ea.; 1 amp PULL TYPE REQUIRED for PAC45, 0.5 A for CTL45s
- b. Optional Circuit Breaker: 0.5 ea.; 1 amp PULL TYPE REQUIRED for PAC45 aural alerts
- c. Headphone Jacks (**Stereo**, as Required)
- d. Microphone Jacks (as Required)
- e. Headphones, 150 Ω (**Stereo**), as required
- f. Microphones, as required
- g. Interconnect Wiring

## 1.8 Configurations

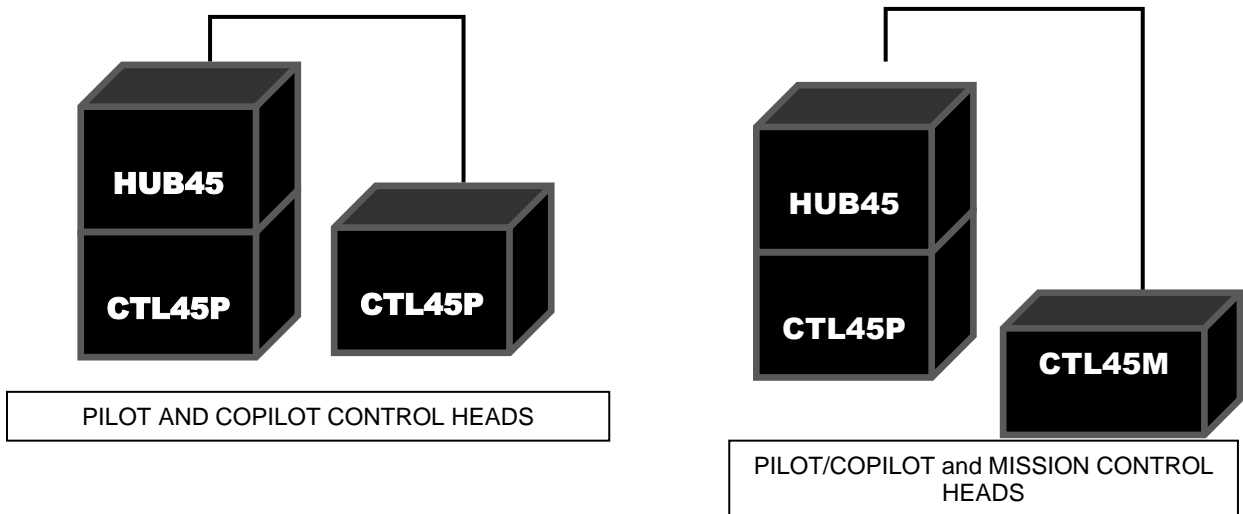
The PAC45 System is comprised of three “building blocks” to facilitate flexibility as well as simplicity.

The simplest, single audio controller system is a PAC45 where the audio hub is attached to the control head.



**Figure 1-2 Single panel configuration**

A second control head can be added, wired into the PAC45 either for a copilot (CTL45P) or as an observer instead of a copilot, CTL45M.



**Figure 1-3 Two control head configurations**

The system is capable of supporting a total of three control heads, pilot, copilot and observer. One control head can be attached to the audio hub (HUB45) or all three can be remote mounted.

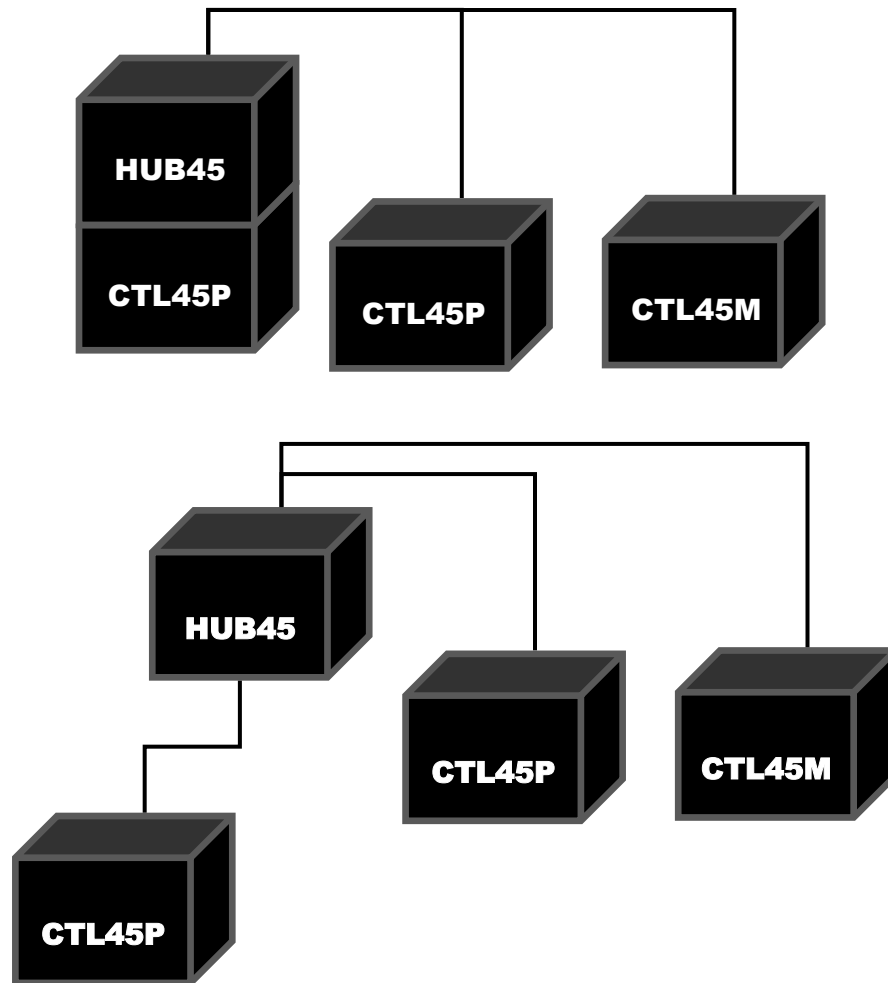


Figure 1-4 Three control head configurations

## 1.9 LICENSE REQUIREMENTS

None

PAC45 Bluetooth™ Radio approval:

- FCC ID: QQQWT32I
- Industry Canada ID: 5123A-BGTWT32I
- CE EMC Directive 89/336/EEC as amended by Directives 92/31/EEC and 93/68/EEC

### NOTE

Unauthorized use of unapproved cellular telephone devices in aircraft is subject to FCC enforcement action, which may include a \$10,000 fine per incident.

FCC Regulation 47 CFR § 22.925 *Prohibition on airborne operation of cellular telephones.*

Cellular telephones installed in or carried aboard airplanes, balloons or any other type of aircraft must not be operated while such aircraft are airborne (not touching the ground). When any aircraft leaves the ground, all cellular telephones on board that aircraft must be turned off.

PS Engineering, Inc. does not endorse using unapproved cellular telephone equipment in flight, and takes no responsibility for the user's action.

PS Engineering does not guarantee compatibility with personal cellular telephones.

## Section II - INSTALLATION

### 2.1 GENERAL INFORMATION

#### 2.1.1 SCOPE

This section provides detailed installation and interconnection instructions for the PS Engineering PAC45 Audio Selector Panel/Intercom.

Please read this manual carefully before beginning any installation to prevent damage and post-installation problems.

Installation of this equipment requires special tools, test equipment (refer to §2.12.1) and installer knowledge as required by 14 CFR 65.81 (b).

#### 2.1.2 Certification Requirements

##### NOTE

The PAC45 requires specialized knowledge and tools for an effective installation. An appropriately rated Certified Aircraft Repair Station **must** install this equipment in accordance with applicable regulations. PS Engineering, Incorporated warranty is not valid unless the equipment is installed by an authorized PS Engineering, Incorporated dealer.

Failure to follow any of the installation instructions, or installation by a non-certified individual or agency will void the warranty, and may result in an **unairworthy** installation.

This article meets the minimum performance and quality control standards required by a technical standard order (TSO). Installation of this article requires separate approval. Refer to AC 20-41A for information regarding Substitute TSO Aircraft Equipment.

### 2.2 Unpacking and Preliminary Inspection

Use care when unpacking the equipment. Inspect the units and parts supplied for visible signs of shipping damage. Examine the unit for loose or broken buttons, bent knobs, etc. Verify the correct quantity of components supplied with the list in §1.6. If any claim is to be made, save the shipping material and contact the freight carrier. Do NOT return units damaged in shipping to PS Engineering. If the unit or accessories show any sign of external shipping damage, contact PS Engineering to arrange for a replacement. Under no circumstances attempt to install a damaged unit in an aircraft. Equipment returned to PS Engineering for any other reason should be shipped in the original PS Engineering packaging, or other UPS approved packaging.

### 2.3 Equipment Installation Procedures

#### 2.3.1 Cooling Requirements

Forced air-cooling of the PAC45 is not required. However, the units should be kept away from heat producing sources (i.e. defrost or heater ducts, dropping resistors, heat producing avionics) without adequate cooling air provided.

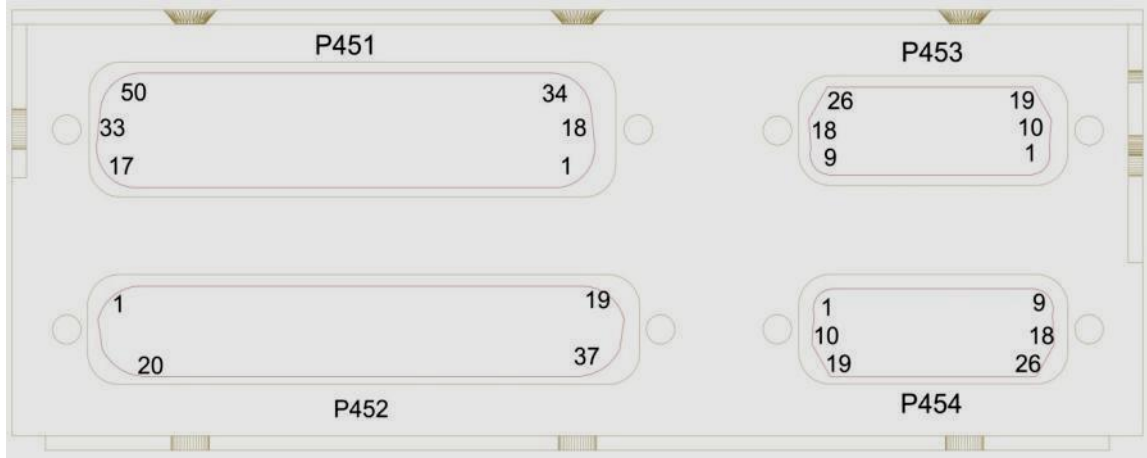
#### 2.3.2 Mounting Requirements

The PAC45 must be rigidly mounted to the instrument panel of the aircraft structure, within view and reach of the pilot position(s). The PAC45/CTL45 is designed for Dzus-rail mounting. Installation must comply with FAA Advisory Circular AC 43.13-2B, or other FAA-approved aircraft technical data. The unit may be mounted in any area where adequate clearance for the unit and associated wiring bundle exist.

To prevent noise, avoid installing the unit close to high current devices or systems with high-voltage pulse type outputs, such as DME or transponders. Avoid running the interconnecting bundles near any high current wires.

### 2.3.3 Audio controller Connector Assembly

The LRU connectors mate with one 50-pin, one 37-pin, and two 26-pin connectors in the PAC45. The connectors are a sub-miniature crimp-type, and require the use a hand crimp tool, from table below (or equiv.).



**Figure 2-1 - PAC45 Connector Layout**

NOTE: The 50-pin and 37-pin connectors are pin-compatible with most NAT AMS-series and Jupiter JA95-series audio controllers. Refer to the connector pin maps to confirm compatibility. The two 26-pin connectors are used to give the PAC45 systems added capability. The PAC45 LRU Hub can be remote mounted, and connections to control head(s) CTL45. Ensure that proper strain relief and chafing precautions are made during wiring and installation.

| Manufacturer | Crimping Tool | Positioner   | Extraction tool |
|--------------|---------------|--------------|-----------------|
| AMP          | 601966-1      | 601966-6     | 91067-1         |
| Daniels      | AFM8          | K42          | M24308-1        |
| ITT-Cannon   | 995-0001-584  | 995-0001-739 | 91067-1         |

**Table 2-1 Connector Pin crimping tools**

### 2.3.4 Thumbscrew and Slide Lock (AMS compliant) connector assembly

Existing installation may utilize slide-locking mechanisms on their connectors. PS Engineering has included slide lock posts with the 26-pin connector kits for your convenience. You can remove the 5mm hex standoffs from the 37 and 50-pin connectors and replace with the 5mm post to keep the existing connectors. Picture below shows slide lock post installed.



PS Engineering recommends that Loctite #425 be added to any thumbscrew that is removed and reinstalled. Loctite #425 is added to the thumbscrew threads at the factory.

## **2.4 Cable Harness Wiring**

Referring to the appropriate Appendix, assemble a wiring harness as required for the installation. All wires must be MIL-SPEC in accordance with current regulations. Two- and three-conductor shielded wire must be used where indicated, and be MIL-C-27500 or equivalent specification. Proper stripping, shielding and soldering technique must be used at all times. It is imperative that correct wire be used.

Refer to FAA Advisory Circular 43.13-2B for more information. Failure to use correct techniques may result in improper operation, electrical noise or unit failure. Damage caused by improper installation will void the PS Engineering warranty.

See Appendix C and D for intercom connection configurations. It is critical to the proper operation of this system to have this connector wiring made in accordance with these diagrams. Use 2- and 3-conductor, MIL-spec cable as shown. Connect the shields at the audio controller end only, and tie to the audio low inputs as shown.

### **2.4.1 Electrical Noise**

Due to the variety and the high power of radio, equipment often found in today's aircraft, there is a potential for both radiated and conducted noise interference.

The PAC45 power supply is specifically designed to reduce conducted electrical noise on the aircraft power bus by at least 50dB. Although this is a large amount of attenuation, it may not eliminate all noise, particularly if the amplitude of noise is very high. Shielding can reduce or prevent radiated noise (i.e., beacon, electric gyros, switching power supplies, etc.) However, installation combinations can occur where interference is possible. The PAC45 was designed in an RFI hardened chassis and has internal Electromagnetic Interference (EMI) filters on all inputs and outputs.

Ground loop noise occurs when there are two or more ground paths for the same signal (i.e., airframe and ground return wire). Large cyclic loads such as strobes, inverters, etc., can inject noise signals onto the airframe that are detected by the audio system. Follow the wiring diagram very carefully to help ensure a minimum of ground loop potential. Use only Mil Spec shielded wires (MIL-C-275000, or better). Under no circumstances combine a microphone and headphone wiring into the same shielded bundle. Always use a 2- or 3-conductor, shield wire as shown on the installation-wiring diagram.

The shields can be daisy-chained together, and then connected to the ground.

Radiated signals can be a factor when low-level microphone signals are "bundled" with current carrying power wires. Keep these cables physically separated. It is very important that you use

insulated washers to isolate the ground return path from the airframe to **all** headphone and microphone jacks.

#### 2.4.1.1 Music Input and Noise

PAC45 units utilize a differential ground input to help prevent noise from entering the audio system. This feature is usually transparent to the installer; however, it is important that the appropriate music signal and ground connections are made directly to the dedicated music signal and ground inputs on the PAC45. The power for IFE and audio controller should be a common bus.

#### **NOISE NOTE**

Adding a high-performance audio control system, particularly in conjunction with high-performance active noise canceling headsets, cannot improve on older avionics that were designed for cabin-speaker use. PS Engineering makes no claim that the audio controller will provide a noise-free audio quality under all installation conditions, particularly with older avionics.

#### 2.4.2 Power

The PAC45 is compatible with 28 Volt DC systems. A one (1) Amp circuit breaker is required for all installations. Power and ground wires should be #22AWG connect power to P451 Pin 17. Connect airframe ground to P451 Pin 34 only.

Power consumption is as follows:

At 28V:

- Hub + Control Head: 500 mA
- Control head Only: 150 mA
- Hub Only: 350 mA
- Alert audio power: 10mA

At minimum input voltage (18V):

- Hub + Control Head: 750mA
- Control head Only: 200mA
- Hub Only: 500mA

Lighting input: <5mA

Units with serial Number LH01217 and above incorporate a power indicator light that is viewable with the gold label on the right side (closer to P453) partly removed. Extra labels are included with the unit.

**CAUTION: Do not connect or disconnect (HOT SWAP) any components with power applied, this may damage the units.**

#### 2.4.2.1 Alert power, P451 Pin 16,

The PAC45 has an independent alert system with the ability to play alerts even when the audio controller is powered off. To take full advantage of this isolation a separate one (1) Amp circuit breaker is required. Power should be #22AWG connect power to P451 Pin 16.

When power to P451-16 is present, the message will play three times or until the remote acknowledge is selected.

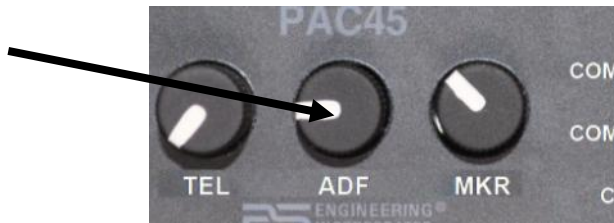


### 2.4.3 Audio controller interface

The PAC45 is designed to interface with standard aircraft avionics, and presents a 510 Ω receiver impedance. For best results, a twisted-shielded cable is recommended from the avionics audio source to the audio controller, with the shield grounded at the audio controller end. Some avionics do not provide a separate audio low, and may introduce additional electrical noise into the system. For best results, connect the audio low from the audio controller to the radio ground, using one conductor of the twisted-shielded cable.

#### 2.4.3.1 Navaid wiring and selection

The PAC45 has NAV 1, NAV 2, and three additional auxiliary navaid inputs for ADF, DME, etc. The three auxiliary audio inputs on P452 pins 9, 10 and 11 will be presented with the center audio control on the bottom row is selected.



#### 2.4.3.2 Additional transmit position or passenger 6 (P451-6, 23, 40)

The PAC45 system can support six passenger intercom stations, in addition to the pilot and copilot. The input to the PAC45 P451 6, 23, 40 can be used as an additional transmit position, or a hand microphone, or as passenger 6, with transmit capability on the selected radio.

This microphone transmitter follows the last control head selection as follows:

| Configuration       | Microphone connected to |
|---------------------|-------------------------|
| Single Control Head | Selected radio          |
| Two Control Heads   | Copilot selected radio  |
| Three Control Heads | Observer selected radio |

Passenger 2 (Observer 2) can use this hand mic as a transmit seat.

#### 2.4.3.3 Passenger 5 and 6

Passenger 6 is an intercom station input on P454-16 wrt 25.

The headphone outputs for passenger 5 and 6 are paralleled from passenger 1 and passenger 2.

**NOTE: Do not parallel headphones to passenger 3 or 4.**

#### 2.4.3.4 Installation with Monaural Headsets

Not recommended, because the benefit of MultiTalker is lost. However, if desired, the PAC45 can be installed monaurally by shorting the left AND right headphone outputs together.

**NOTE These companies adapt monaural helmets and headsets to stereo:**

|  |   |   |  |
|--|---|---|--|
| Lightspeed Avionics<br>Phone: 800-332-2421<br><a href="http://www.lightspeedaviation.com">www.lightspeedaviation.com</a> | Acousticom<br>Phone: 574-293-0534<br><a href="http://www.acousticom.com">www.acousticom.com</a> | FLIGHTHELMET.COM<br>Phone: (800) 531-4898<br><a href="http://www.FlightHelmet.com">www.FlightHelmet.com</a> | Headsets Inc.<br>Phone: 800-876-3374<br><a href="http://www.headsetsinc.com">www.headsetsinc.com</a> |
|--|---|---|--|



**NOTE: Mono headsets that short the tip and ring (i.e., older models) may introduce audio distortion when used. Modern, stereo headsets are recommended in all positions.**



### 2.4.4 Transmit Interlock

Some communications transceivers use a transmit-interlock system. To fully utilize the multi-user, transmit capability, this function must be disabled. Consult the radio manufacturer's installation manual.

### 2.4.5 Backlighting

Control of the unit backlighting is through the aircraft avionics dimmer. Connect P452 Pins 19 to the aircraft dimmer bus. All control heads dimming is control by the HUB. The audio controller can be configured for either 5VDC or 28V dimmer installations. The default setting is 28V from the factory. The ratio of white to green indicator intensity is adjustable, see [§2.5.2.1](#).

| Mode                    | Operation (For serial number MH01281 and above)   |
|-------------------------|---|
| Night Mode and Day Mode | <b>Night Mode:</b> Dimmer pot (above trip level) adjusts brightness from minimum to full brightness as set by programming pots. See <a href="#">§2.5.3.3</a><br><b>Day Mode:</b> Below trip level sets brightness to full brightness as set by programming pots (separate settings from Night Mode settings). |
| Night Mode Only         | Dimmer pot (trip level adjusted to zero) adjusts brightness from minimum to full brightness as set by programming pots.   |
| Day Mode Only           | No dimmer pot connected, sets brightness to full brightness as set by programming pots.   |

### 2.4.6 Unswitched inputs

These inputs are presented to the pilot and copilot regardless of the audio configuration and will always mute the crew entertainment inputs. These 510Ω inputs can be used for altimeter DH audio, GPS waypoint audio, autopilot disconnect tones, or any other critical audio signal. Unswitched #1 is always presented to the crew headphones and is available to the pilot in fail-safe (off) mode.

| Un-switched Input | Input Pins       | Hear in Fail Safe | Hear in Crew Headset | Adjustable at installation |
|-------------------|------------------|-------------------|----------------------|----------------------------|
| 1                 | P452 - 13 WRT 32 | Yes               | Yes                  | Yes                        |
| 2                 | P452 - 1 WRT 20  | No                | Yes                  | Yes                        |
| 3                 | P454 - 14 WRT 23 | No                | Yes                  | Yes                        |
| 4                 | P454 - 13 WRT 22 | No                | Yes                  | Yes                        |

Table 2-2 Unswitched inputs

### 2.4.7 Cockpit Voice Recorder

The PAC45 audio controller contains a Cockpit Voice Recorder output for the pilot and copilot. Pilot CVR output is P454-12; Copilot CVR output is P454-2, both with respect to CVR low, P454 21.

The CVR output is consistent with RTCA DO-214A §1.5.7. When the pilot is in failsafe and hearing UNSW1, the CVR will also record UNSW1 - 4.

The copilot CVR output can be modified to remove intercom audio if desired by the user. This makes it incompatible with regulations where an official CVR is required, but desirable for other applications. See [§2.4.11.7](#)

### 2.4.8 Audio Alerts

The PAC45 contains an independent audio alerting systems that will play up to three alert audio messages that can be stored by the user (see [§3.11.1](#)). For convenience three alerts are stored at the factory.

The alert system has a power input (P451-16) that will keep the systems operable if the PAC45 systems power source is removed. **Alert audio is ONLY provided in Fail-safe when power is applied to P451-16.**

| Alert Input        | Input Pins | Factory Stored Audio |
|--------------------|------------|----------------------|
| 1                  | P451 – 11  | “Master Caution”     |
| 2                  | P451 – 12  | “Alert”              |
| 3                  | P451 – 13  | Chime tone           |
| Alert Power        | P451 – 16  |                      |
| Remote Acknowledge | P454-9     |                      |

The alert triggers can be configured to be Active High (>4.5 VDC) or Active Low (<0.5 VDC), and trigger at the leading-edge transition or by the voltage level. See [§2.5.3](#) for configuration options.

Alerts with edge triggers will play three times or until the front panel Acknowledge button (ACK) is pressed (or the remote ACK P454-9 grounded).

Alerts with level trigger will play three times or until the front panel Acknowledge button (ACK) is pressed (or the remote ACK P454-9 grounded), or the input level reverts.

When power is applied to the alerts and not the PAC45 audio controller, it will play the message three times or until the remote acknowledge is selected.

Audio alerts are inhibited for the first 30 seconds after power up to reduce nuisance triggers.

#### 2.4.8.1 External Alert Acknowledge Switch (J454-9)

A momentary SPST switch, installed between J454-9 and ground, can act the same as the crew Control Head ACK button. If J454-9 is permanently connected directly to aircraft ground, all alerts will be played one time after trigger, and stop.

#### 2.4.8.2 Remote ICS mode control.

When a momentary, normally open, push-button switch is connected between pin P454-18 and ground, it will change the intercom mode on the Pilot's PAC45.

### 2.4.9 Wired Telephone/Satellite Communication input

The PAC45 can accommodate a wired cell phone interface on P454 Pins 17, 26 and 7.

Both Bluetooth and wired Telephone and be accommodated, however, only ONE can be active at a time.

Low impedance satellite phones might require a tactical radio adapter, PS Engineering P/N 12100.

## 2.4.10 Music Input

### NOTE

Use the low-level output of any additional Music device to connect to the audio controller. Maximum signal level is **3 VAC** p-p. **DO NOT** use a speaker-level output; this will cause internal damage in the audio controller.

### CAUTION

Local oscillators and internal signals from Music equipment can cause undesired interference with other aircraft systems. Before takeoff, operate the entertainment devices to determine if there is any adverse effect within the aircraft systems. If any unusual operation is noted in flight, immediately switch off the entertainment devices.

All additional entertainment devices must be switched off for both takeoff and landing.

## 2.4.11 Functional Options

There are several optional features in the PAC45 system that are configured by PS Engineering based on customer responses to a questionnaire. The status of these modification options is shown on a Modification Identifier tag on the PAC45 (**HUB45 s/n MH01266 and below**).



For S/N MH01267 and above, the status is shown by the DIP switch position.

### 2.4.11.1 Intercom Active during PTT press (-TXI) (**MOD #1**)

When this option is used, the intercom audio is NOT muted when a crewmember is transmitting on the radio. Ideal for tactical operations where air to ground and inter aircraft communication occur simultaneously.

### 2.4.11.2 Receive Activity Indicator (-RXI) (**MOD #2**)

PAC45 systems (HUB45 Serial Number DH1069 and above) have an optional Receive Activity Indicator that flashes the selected receiver indicator when a signal is present on that receiver.

### 2.4.11.3 Reversionary Mode (**MOD #3**)

This option is applied normally and may be requested to be disabled. When enabled, if any control head is shut off (EMG mode), those users will revert to the flight crew's CTL45 and hear the radio and intercom audio selected by the copilot.

If the Reversionary Mode is NOT applied, when a CTL45 is switched to EMG, those users will hear nothing.

### 2.4.11.4 Simulcast (**MOD #4**)

In a simulcast, the same transmit signal audio is sent to more than one transceiver. The intent of simulcast is to quickly transmit the same signal to more than one location reducing the transmit

workload or having to repeat the same transmission manually. See [§3.3.1](#) for operational information.

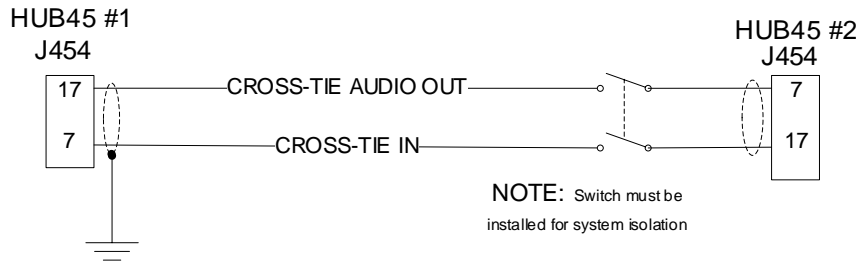
#### 2.4.11.5 Unswitched Audio present in passenger audio (MOD #7)

When MOD 7 is present, the direct/unswitched audio is provided to the passenger intercom audio as well as the crew. This is useful if the passengers need to hear the unswitched audio for tactical reasons.

#### 2.4.11.6 Dual system configuration (MOD #10)

Specially configured HUB45s can be interfaced to create a dual systems with up to six control heads, 6 coms or 5 coms + 1 sat phone. The audio tie line connects P454 pin 7 on one HUB45 to P454 pin 17 on the other HUB45. If isolation is desired install a switch in the tie-line.

NOTE: This uses the wired TEL port, so this system can't be used with a wired telephone. See §3.12.5 for operational details.



**Figure 2 – Dual HUB45 Interface**

#### 2.4.11.7 Special Recorder Out (MOD #11)

Applies to HUB45 P/N 050-045-0102, S/N JBH01370 and above. This removes intercom audio from copilot's SPR/CVR output (J454 Pin 2 and Pin 21). The audio present on this line will follow the last control head installed, whether it's a single, dual or three control head system.

*Example:* When a TFO control head is installed, the tactical radios selected will be present on this recorder output. This output can be wired to a Churchill Navigation / SHOTOVER camera system as an example.

Setting switch 6, (internal dipswitch) Recorder Output Function, MOD 11. [See §2.4.7.](#)

1. Power off the HUB45.
2. Set the Recorder Out switch (Switch #6) up.
3. Power on the HUB45.
4. Hold down the **ICS** button on the *pilot's* control head for 3 seconds or until you hear the "beep", this will program the special mode.
5. Power off the HUB45 and set the Recorder Out (Switch #6) to down.
6. Test the function.

NOTE: This function is incompatible with a pilot low-level speaker output.

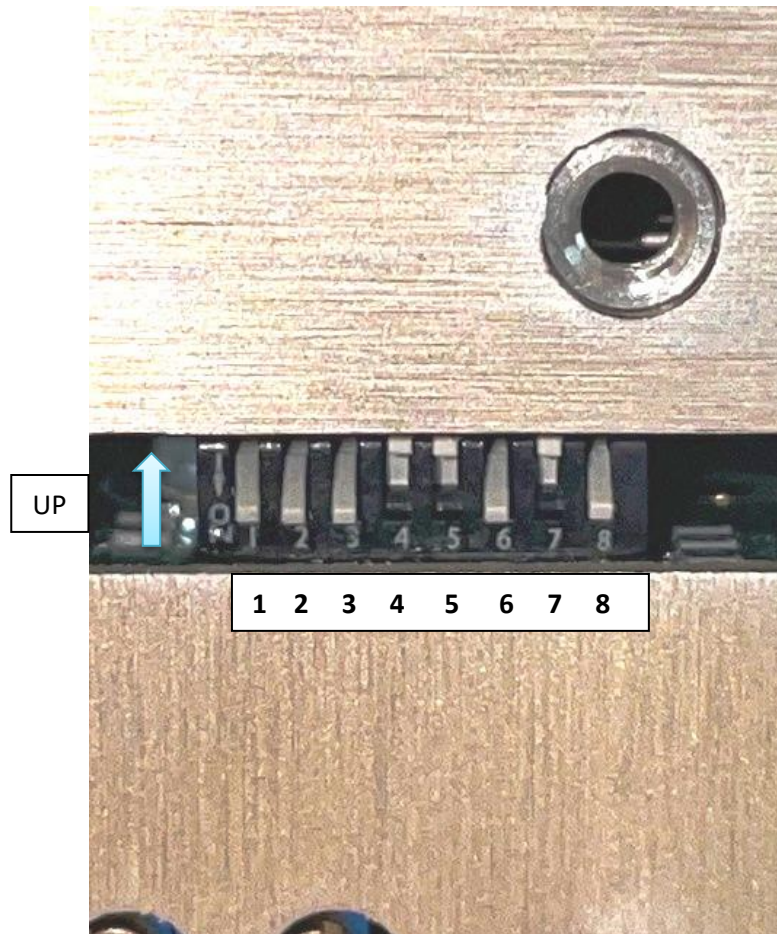
#### 2.4.12 Internal DIP Switch configuration (S/N MH01267 and above)

There are eight switches accessible through the side of the HUB45 unit that provide field configurability of the functions listed above in §2.4.11. In a clean bench environment, carefully remove the side plate closest to the 9-Pin connector by removing the side plate closest to the 9-Pin connector by removing eight #4-40 x 3/16 Philip screws and star washers.

**PS Engineering**  
PAC45 Audio Selector Panel and Intercom System  
Installation and Operator's Manual

Place the switch in the UP position to select the functions below.

| Switch # | Mod # | Description  | Function Active                               |
|----------|-------|--|---|
| 1        | 1     | TXI- Intercom stays active during PTT presses                | UP  |
| 2        | 2     | RXI- Comm Text flashes when audio is active                  | UP  |
| 3        | 3     | Reversionary Mode  | UP  |
| 4        | 4     | Simulcast Transmit<br>(requires special CTL45 Configuration) | UP  |
| 5        | 5     | Artificial Transmit Sidetone                                 | UP  |
| 6        | 6     | Recorder Out Select (S/N JHB01370 & higher)                  | KEEP DOWN<br>UNLESS<br>ACTIVATING<br>FUNCTION |
| 7        | 7     | Passengers hears unswitched input                            | UP  |
| 8        | 8     | Passengers will not hear radios in any ICS mode              | UP  |
|          | 9     | AMS44 Configuration, for PAC45D only                         |   |
|          | 10    | Dual HUB Installation (Special Build)                        |   |

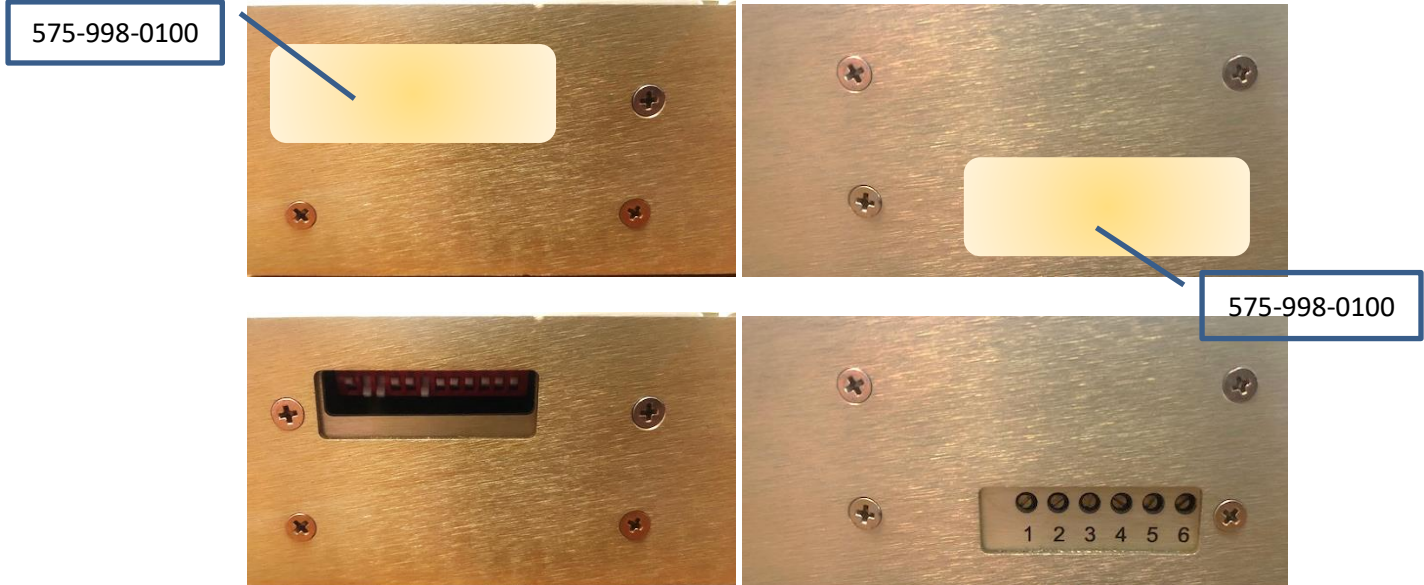


After setting the required switched, re-install the side plate. PS Engineering recommends adding a small amount of Loctite 425 to the screws.



## 2.5 Installer Adjustments

The PAC45 is factory set for typical installation. However, several installation adjustments are available. No computer is required. These are located behind removable labels on each side of the PAC45 (two additional replacement labels are included with the installation kit.)



### 2.5.1 Unswitched Audio Level

Unswitched inputs one through four are installation adjustable through the side of the PAC45 unit.

### 2.5.2 Adjustments

On the side of the PAC45/HUB45R are six adjustment potentiometers.



**Figure 2-3— Adjustment potentiometers (NOTE these are all 30-Turn pots, and may require 10-15 turns to notice any change)**

Alert volume (adjusts the level of the internal audio alerts and annunciations generated by the PAC45)

1. Alert Audio Overall volume level
2. White & Green text backlight level adjust (see §2.5.2.1)

3. Unswitched input 1 volume
4. Unswitched input 2 volume
5. Unswitched input 3 volume
6. Unswitched input 4 volume

### 2.5.2.1 Green and White lighting adjustment

The #2 potentiometer adjusts the white intensity by default.

The green indication level can be adjusted to match the white level or for user preference. This should be done *before* adjusting the white, as setting the green will overwrite the white setting.

1. Hold the ACK and HRTF buttons at the same time until a chime is heard in the headset.
2. Adjust the #2 potentiometer (see §2.5.2, above).
3. Push ACK to exit the green adjust mode and return to white adjustment.
4. Adjust the white text lighting as desired with #2 potentiometer.

### 2.5.2.2 Green and White lighting adjustment (Configuration BBGAA)

Units with Configuration BBGAA and above, the dimming has been modified to set a minimum level:

- By default, adjustments to the pot change the minimum trip point for the dimmer input to full bright. The pot permits adjustment from 0V to nominal dimmer voltage (28V or 5V depending on configuration).
- The following steps must be taken in this specific order.
  1. Enter programing mode with a long press (3 seconds) of HRTF and ACK on pilot panel which will cause the #2 potentiometer to adjust the green level. When in this mode the green LEDs will get brighter or dimmer.
  2. Another long press (3 seconds) of HRTF and ACK on pilot panel will adjust the white level
  3. Another long press (3 seconds) of HRTF and ACK will exit programming mode
  4. Also, ACK can be pressed at any time to exit (if you want to adjust green but not white for example)
  5. Finally, adjust the dimmer trip level. Even if adjusted prior to the green/white adjustment, it will have to be readjusted because the #2 potentiometer has moved.

### 2.5.2.3 Units with serial number **MH01281** and above (Day/Night Mode):

| Mode                    | Operation   |
|-------------------------|---|
| Night Mode and Day Mode | <p><b>Night Mode:</b> Dimmer pot (above trip level) adjusts brightness from minimum to full brightness as set by programming pots.</p> <p><b>Day Mode:</b> Below trip level sets brightness to full brightness as set by programming pots (separate settings from Night Mode settings).</p> |
| Night Mode Only         | Dimmer pot (trip level adjusted to zero) adjusts brightness from minimum to full brightness as set by programming pots.   |
| Day Mode Only           | No dimmer pot connected, sets brightness to full brightness as set by programming pots.   |

1. Long Press HRTF/ACK, a single Chime (indicates programming Green LEDs), adjust pot to set Night Mode Green level.
2. Long Press HRTF/ACK, a double Chime (indicates programming White LEDs), adjust pot to set Night Mode White level.



3. Long Press HRTF/ACK, a single Chime (indicates programming Green LEDs), adjust pot to set Day Mode Green level.
4. Long Press HRTF/ACK, a double Chime (indicates programming White LEDs), adjust pot to set Day Mode White level.
5. Long Press HRTF/ACK, a triple Chime (indicates programming Trip Level), adjust pot to set trip level.

### 2.5.3 Logic Switch Options

The PAC45 has several switches accessible through the side of the HUB45 to set specific functions.

Power must be cycled after selections are completed.



Switch going towards the number is “UP” Switch going away from the number is “DOWN”

| Switch # | Description                     | SWITCH UP                       | SWITCH DOWN                       |
|----------|---------------------------------|---------------------------------|-----------------------------------|
| 1        | Alert Trigger #1 Logic          | Active Low (Ground)             | Active High (Voltage)             |
| 2        | Alert Trigger #2 Logic          | Active Low (Ground)             | Active High (Voltage)             |
| 3        | Alert Trigger #3 Logic          | Active Low (Ground)             | Active High (Voltage)             |
| 4        | Alert Trigger #1 Type           | Level Trigger                   | Edge Trigger                      |
| 5        | Alert Trigger #2 Type           | Level Trigger                   | Edge Trigger                      |
| 6        | Alert Trigger #3 Type           | Level Trigger                   | Edge Trigger                      |
| 7        | Dimmer Voltage                  | 5 Volt Dimmer Input             | 28 Volt Dimmer Input              |
| 8        | High Aircraft Noise Sensitivity | Standard Microphone Sensitivity | High Noise Microphone Sensitivity |
| 9        | Passengers’ HRTF Selection      | Disabled                        | Enable                            |
| 10       | Offside Com audio active        | Coms are heard                  | Coms are not heard                |
| 11       | Copilot Control Head Installed  | No                              | Yes                               |
| 12       | Observer Control Head Installed | No                              | Yes                               |

#### 2.5.3.1 Alert Trigger Logic (1 – 3)

Switches 1-3 set alert logic. DOWN for active high (>4.5 VDC), UP for active low (<0.5 VDC).

#### 2.5.3.2 Alert Trigger Type (Switches 4 – 6)

Switches 4-6 set alert type. UP for level triggered, DOWN for edge triggered.



Alerts with edge triggers will play continuously until the Acknowledge button (ACK) is pressed (Remote ACK P454-9 grounded).

Alerts with level trigger will play continuously until the Acknowledge button (ACK) is pressed (Remote ACK P454-9 grounded), **or** the input level reverts.

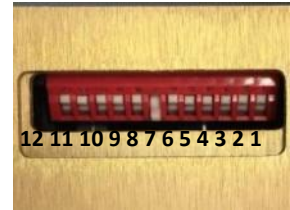
As shown: Alert 1 Edge Triggered, Alerts 2-3 Level Triggered (default from factory)

UP

### 2.5.3.3 Back light dimmer voltage (Switch 7)

Switch 7 sets dimmer mode. UP for 5V, DOWN for 28V

As shown: 28V dimmer (default from factory).



### 2.5.3.4 Microphone Sensitivity (Switch 8)

Switch 8 sets mic sensitivity. UP for low noise (standard), DOWN for high noise environment.

As shown: High noise

### 2.5.3.5 Passenger Head Related Transfer Function (HRTF) Disable (Switch 9)

Switch 9 enables HRTF mode for passengers. UP disabled, DOWN enabled. Disable *only* if headsets are monaural.



### 2.5.3.6 Offside com audio active during transmit – (Switch 10)

When this switch is in the “UP” position, the receive audio on other radios is not muted when one crew member transmits on the radio. This allows other crewmembers to listen to other radios while one transmits. (shipped from factory in this mode. Serial Number DH01069 and above).

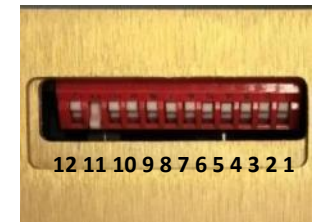
NOTE: This may result in crosstalk if multiple radios are tuned to close frequencies.



### 2.5.3.7 Copilot Control head (Switch 11)

Switch 11 indicates that a CTL45P is installed as a copilot control head.

UP for copilot CTL45P not installed, DOWN for copilot control head present.



### 2.5.3.8 Mission/Observer Control head (Switch 12)

Switch 12 indicates that a CTL45M is installed as the Observer/Mission control head.

UP for CTL45M not installed, DOWN for observer/mission position control head present.

As shown: Observer Control Head in System



## 2.6 PAC45 Pin assignments

| P451 |                                 | P452 |                       |
|------|---------------------------------|------|-----------------------|
| Pin  | FUNCTION                        | PIN  | FUNCTION              |
| 1    | COM2 KEY                        | 1    | UNSWITCHED AUDIO 2    |
| 2    | COM1 KEY                        | 2    | COM 2 AUDIO HI        |
| 3    | COM3 KEY                        | 3    | COM 1 AUDIO HI        |
| 4    | COM4 KEY                        | 4    | COM 3 AUDIO HI        |
| 5    | COM5 KEY                        | 5    | COM 4 AUDIO HI        |
| 6    | OBSERVER PAX 6/HAND MIC KEY     | 6    | COM 5 AUDIO HI        |
| 7    | PILOT MIC KEY                   | 7    | NAV 1 AUDIO HI        |
| 8    | COPILOT MIC KEY                 | 8    | NAV 2 AUDIO HI        |
| 9    | PILOT ICS PTT                   | 9    | ADF 1 AUDIO HI*       |
| 10   | COPILOT ICS PTT                 | 10   | ADF2 AUDIO HI*        |
| 11   | ALERT 1 TRIGGER                 | 11   | DME AUDIO HI*         |
| 12   | ALERT 2 TRIGGER                 | 12   | MKR AUDIO HI          |
| 13   | ALERT 3 TRIGGER                 | 13   | UNSWITCHED AUDIO 1    |
| 14   | PA MIC OUTPUT HI                | 14   | MUSIC LEFT HI         |
| 15   | PA MIC LO                       | 15   | MUSIC RIGHT HI        |
| 16   | ALERT POWER                     | 16   | NO CONNECTION         |
| 17   | AIRCRAFT POWER                  | 17   | COPILOT PHONES (L) HI |
| 18   | COM2 MIC AUD                    | 18   | PILOT PHONES (L) HI   |
| 19   | COM1 MIC AUD                    | 19   | 28 V LIGHTS           |
| 20   | COM3 MIC AUD                    | 20   | UNSWITCHED AUDIO 2 LO |
| 21   | COM4 MIC AUD                    | 21   | COM 2 AUDIO LO        |
| 22   | COM5 MIC AUD                    | 22   | COM 1 AUDIO LO        |
| 23   | PAX 6/HAND MIC AUD              | 23   | COM 3 AUDIO LO        |
| 24   | PILOT MIC AUD IN                | 24   | COM 4 AUDIO LO        |
| 25   | COPILOT MIC AUD IN              | 25   | COM 5 AUDIO LO        |
| 26   | PASS1 MIC AUD                   | 26   | NAV 1 AUDIO LO        |
| 27   | PASS2 MIC AUD                   | 27   | NAV 2 AUDIO LO        |
| 28   | PAX 3 MIC AUDIO                 | 28   | ADF 1 AUDIO LO        |
| 29   | PAX 4 MIC AUDIO [EXP. AUDIO IN] | 29   | ADF 2 AUDIO LO        |
| 30   | PAX 1/OBSERVER HP OUT           | 30   | DME AUDIO LO          |
| 31   | PAX 2 HP OUT                    | 31   | MKR AUDIO LO          |
| 32   | PAX 3 HP OUT                    | 32   | UNSWITCHED AUDIO 1    |
| 33   | PAX 4 HP OUT [EXP. AUDIO OUT]   | 33   | MUSIC LEFT LO         |
| 34   | AIRCRAFT GND                    | 34   | MUSIC RIGHT LO        |
| 35   | COM 2 LO                        | 35   | NO CONNECTION         |
| 36   | COM 1 LO                        | 36   | COPILOT PHONES LO     |
| 37   | COM 3 LO                        | 37   | PILOT PHONES LO       |
| 38   | COM 4 LO                        |      |                       |
| 39   | COM 5 LO                        |      |                       |
| 40   | PAX 6/HAND MIC LO               |      |                       |
| 41   | PILOT MIC LO                    |      |                       |
| 42   | COPILOT MIC LO                  |      |                       |
| 43   | PAX 1 MIC LO                    |      |                       |
| 44   | PAX 2 MIC LO                    |      |                       |
| 45   | PAX 3 MIC LO                    |      |                       |
| 46   | PAX 4 MIC LO                    |      |                       |
| 47   | PAX 1 PHONE LO                  |      |                       |
| 48   | PAX 2 PHONE LO                  |      |                       |
| 49   | PAX 3 PHONE LO                  |      |                       |
| 50   | PAX 4 PHONE LO                  |      |                       |

\*Audio presented on same switch/volume control

**PS Engineering**  
PAC45 Audio Selector Panel and Intercom System  
Installation and Operator's Manual

| <b>P453</b> |                                 | <b>P454</b> |  |
|-------------|---------------------------------|-------------|--|
| 1           | SERIAL TX2-                     | 1           | PA KEY (S/N CHB0XXX and up)                |
| 2           | SERIAL TX2+                     | 2           | COPILOT CVR/Low Level SPR out (-0102 only) |
| 3           | PAX 5 ICS PTT                   | 3           | PAX 6 ICS PTT                              |
| 4           | PAX1 ICS PTT                    | 4           | NC   |
| 5           | PAX2 ICS PTT                    | 5           | NC   |
| 6           | PAX3 ICS PTT                    | 6           | NC   |
| 7           | PAX4 ICS PTT                    | 7           | TEL MIC AUD                                |
| 8           | COM 6 KEY                       | 8           | PILOT COM SWAP                             |
| 9           | PAX 1 MIC KEY                   | 9           | ACKNOWLEDGE                                |
| 10          | SERIAL TX3 -                    | 10          | COPILOT HP RT                              |
| 11          | SERIAL RX2 -                    | 11          | PILOT HP RT                                |
| 12          | SERIAL RX2 +                    | 12          | PILOT CVR OUT                              |
| 13          | PAX 1 HP RT                     | 13          | UNSW 4 AUD IN                              |
| 14          | PAX 2 HP RT                     | 14          | UNSW 3 AUD IN                              |
| 15          | PAX 3 HP RT [EXP. AUDIO RT]     | 15          | COM 6 AUD IN                               |
| 16          | PAX 4 HP RT [EXP. AUDIO OUT RT] | 16          | PAX 5 MIC AUD                              |
| 17          | COM 6 MIC HI                    | 17          | TEL AUD IN                                 |
| 18          | NC                              | 18          | REMOTE ISO                                 |
| 19          | SERIAL TX3+                     | 19          | COPILOT HP LOW                             |
| 20          | SERIAL RX3-                     | 20          | PILOT HP LOW                               |
| 21          | SERIAL RX3+                     | 21          | CVR LOW                                    |
| 22          | SERIAL 2 LOW                    | 22          | UNSW 4 AUD LOW                             |
| 23          | SERIAL 2 LOW                    | 23          | UNSW 3 LOW                                 |
| 24          | PAX HP LOW                      | 24          | COM 6 AUD LOW                              |
| 25          | PAX HP LOW                      | 25          | PAX 5 MIC AUD LOW                          |
| 26          | COM 6 MIC LOW                   | 26          | TEL AUD LOW                                |

**Table 2-3: PAC45 Pin Assignments**

NOTE: Serial TX2 for Copilot Control Head, TX 3 for Mission Observer Control Head [Brackets] indicate pins used for Expansion (P/N 11645)

## 2.7 Wiring Checkout

After wiring is complete, verify power is ONLY on pin 16 & 17 of J451 and airframe ground on pin 34. Failure to do so will cause serious internal damage and void PS Engineering's warranty.

**CAUTION: Do not connect or disconnect (HOT SWAP) any components with power applied, this will damage the units**

## 2.8 Operational Checkout

### 2.8.1 Required Test Equipment

In order to return an aircraft to service after installation of the PAC45, the installer must have access to headset(s), and be able to establish 2-way communications on appropriate radios. Equivalent test equipment is acceptable as long as the testing requirements can be met.

### 2.8.2 Audio controller Test

**NOTE**

The *IntelliVOX*® is designed for ambient noise levels of 80 dB or above. Therefore, some clipping may occur in a quiet cabin, such as without the engine running, in a hangar. This is normal. Use of a Stereo headset is **required** to obtain full effect of MultiTalker processing.

1. Apply power to the aircraft and avionics.
2. Plug **stereo** headsets into the pilot, copilot, and occupied passenger positions, or monaural if not using HRTF feature.
3. Verify fail-safe operation by receiving and transmitting on com 1 from the pilot position, with the audio controller power off /EMG mode. The Com audio will be present in one ear cup only if stereo headset and both ear cups if using monaural headsets.
4. Switch on the unit by turning the XMT select knob to the full CCW position (COM 1).
5. Check intercom operation.
6. Verify that the COM 1 legend in both the XMT and RCV change to green. Verify that transmit **indicator is not flashing green...** If the LED is flashing green, stop testing and troubleshoot the microphone PTT installation. If for any reason the transmit PTTs are stuck, then they will disconnect after 35 seconds.
7. Verify proper transmit and receive operation from the copilot position, noting that the copilot PTT switch allows proper transmission on the selected transceiver. Verify that the Xmt legend flashes green when the copilot is transmitting.
8. Rotate the XMT knob to the next transceiver position and verify the indicators change to track the selection, and Com 2 receiver is heard.
9. Repeat for remaining transceivers.
10. Verify proper operation of all receiver sources by selecting them using the appropriate knob.
11. Verify proper Intercom system operation in the **ALL**, **ISO** and **CREW** modes (see Table 3-1).
12. Verify that the audio selector panel system does not adversely affect any other aircraft system by systematically switching the unit on and off, while monitoring the other avionics and electrical equipment on the aircraft.

### 2.8.3 Bluetooth Checkout

Verify that the PAC45 will “pair” with a Bluetooth device, and interface with cellular phone and Music source. See [§ 3.7.2](#) for more information.

If PAC45 is not connecting, resetting the Bluetooth memory might be required. Hold down HRTF & ICS buttons for 3 seconds until there is a chime in pilot headset.

#### 2.8.3.1 TEL Checkout

Pair the PAC45 with a Bluetooth telephone device. Verify that the pilot headset is connected to the cellular telephone system (if installed). The telephone function will allow any person heard by the pilot on the intercom, also heard on the telephone.

To make or receive a phone call, you must press the TEL switch in the OUT position on the audio controller panel and verify the volume is turned to an acceptable volume.

The PAC45 has the ability to turn the telephone audio completely off by turning the TEL volume knob all the way CCW.

### **2.9 Final Inspection**

Verify that the wiring is bundled away from all controls and no part of the installation interferes with aircraft control operation. Move all controls through their full range while examining the installation to see that no mechanical interference exists. Verify that the cables are secured to the aircraft structure in accordance with good practices, with adequate strain relief. Ensure that there are no kinks or sharp bends in the cables and coaxial cables. Verify that the cables are not exposed to any sharp edges or rough surfaces, and that all contact points are protected from abrasion.

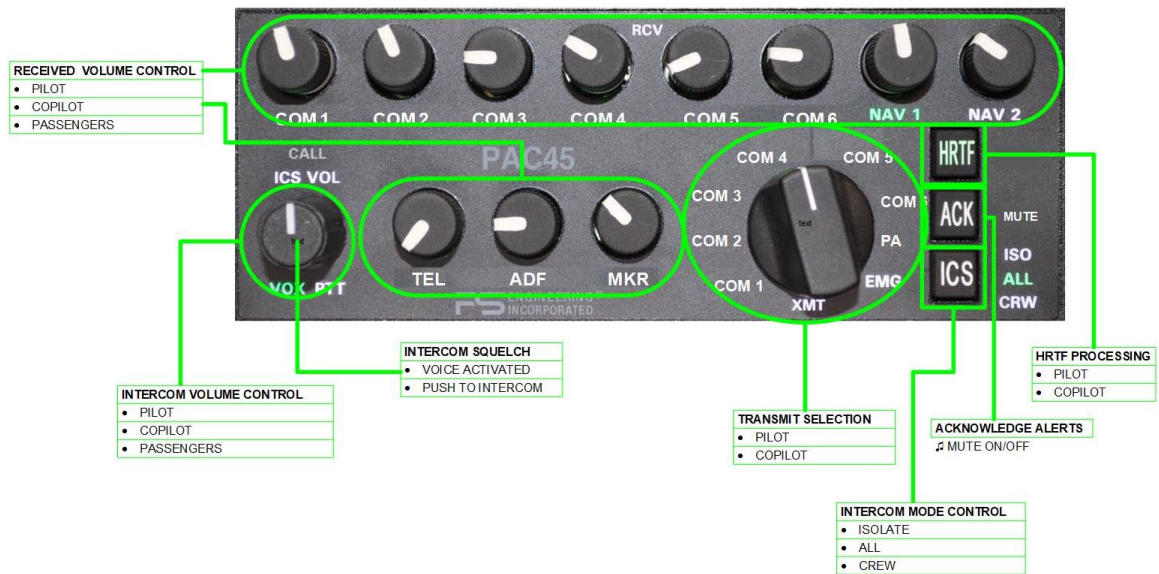
Complete documentation that may be required, such as a logbook entry, weight and balance computation and FAA Form 337. Sample text for FAA Form 337, and instructions for continuing airworthiness can be found in Appendix F. Return completed warranty registration application to PS Engineering, or complete online at [www.ps-engineering.com](http://www.ps-engineering.com).

## Section III OPERATION

### 3.1 SCOPE

This section provides detailed operating instructions for the PS Engineering PAC45, Audio Selector Panel/Intercom Systems. Please read it carefully before using the equipment so that you can take full advantage of its capabilities.

This section is divided into sections covering the basic operating areas of the PAC45 systems. They are Communications Transceiver Selection, Audio Selector, Intercom, and special functions, including the Bluetooth® functionality in the PAC45.



**Figure 3-1 PAC45 Operating Controls**

### 3.2 Power and Fail Safe

Unit power is controlled by the transmitter (XMT) selector knob. In the "EMG" or OFF (fully clockwise) position, the pilot headset is connected directly to COM 1 as well as unswitched input #1 and alerts (if power applied to the alert system independently, see §2.4.8). This allows communication capability regardless of unit condition. NAV1 audio is also provided to the pilot in the other ear of a stereo headset.

Any time power is removed or turned OFF; the audio selector will revert to fail-safe mode. If fail-safe audio is present in both ears of a stereo headset, or completely absent, verify that a stereo headset is used and is selected for stereo mode.

The power controls all audio selector panel functions, and intercom.

### 3.3 Communications Transmit (XMT) Selection

The PAC45 has a rotary control knob to select communications transceiver functions. To select a transceiver for transmit; turn the knob to select the desired radio from the six available.

The radio is automatically selected to receive incoming radio calls when the XMT is selected.

With a PAC45, you will *never* transmit on a radio that you are not receiving. The selected audio is indicated by both knob position and the green text.

Pilot Com Swap (P454 pin 8) switch is available if all six transceivers are present and configured. If less than six coms then pilot com swap is not available.



### 3.3.1 Simulcast (MOD 4 only)

When configured at the factory with MOD 4, the PAC45 is capable of Simulcast. This allows the user to transmit the same audio over multiple radios at the same time. The intent of simulcast is to quickly transmit the same signal to more than one location reducing the transmit workload or having to repeat the same transmission manually.

To enter Simulcast mode, place the XMT selector in SCAST position and select the desired radio RCV selector to the "OUT" position. Then the same microphone audio is transmitted on all selected radios at the same time. The XMT indicators will flash on the audio panel that is transmitting. The pilot will override the copilot if both press their radio PTT at the same time and have selected the *same* radio(s) for transmission. The copilot PTT will override the observer transmission.

### 3.4 COM Audio Selector and Volume

The communications receiver audio sources are controlled by a combination switch/volume control. Communication audio from another radio, not selected for transmit, can be heard by placing the associated RCV switch in the OUT position. The selected audio is indicated by both knob position and the green nomenclature text.

If your control head has a **master radio volume**, turn it full clockwise. This master volume is just an attenuator, and not designed to give additional amplification. It should be used for the purpose of turning down all radios at the same time for training or communicating. Once finished, turn the master volume to max (CW) and leave it there.



Then, turn all switched audio knobs to the one o'clock positions and leave them there.



Finally, go to the specific radio/switch audio source (GTN750/KX155A, etc.) and adjust to slightly above comfortable listening level and leave it there. Now you should never have to adjust the source volume again. If you want the radios to be louder simply adjust the knob on the PAC45A control head.



You will always hear the audio from the selected transceiver, even if the selected com audio is turned all the way down on the audio controller because it cannot turn the selected receive audio all the way off.



### 3.4.1 MultiTalker® Head Related Transfer Function (HRTF)

Communication receiver audio signals are presented to the DSP and processed to “appear” in a different location to the crew. “MultiTalker” (US Patent #7,391,877) specifies up to nine locations. This helps the crew to better comprehend speech by locating it in a manner more easily differentiated by the human brain.

Intercom and other audio is not spatially processed, only the six communications transceivers.

**NOTE: YOU MUST USE STEREO HEADSETS, IN STEREO MODE FOR THIS FEATURE.**

This adjustment allows the six Spatial Audio inputs to be “relocated” on any of nine (9) pre-defined “Head Related Transfer Function” (HTRF) locations.

MultiTalker places the communications receiver audio in one of nine apparent locations in the crew’s headset. This has been scientifically shown to allow the brain to focus on multiple conversations and improve comprehension for the listener.



### 3.4.2 HRTF On /Off

Pressing the HRTF button toggles the PAC45 MultiTalker spatial function on in stereo headset, (receiver sources distributed) or off (receiver audio sources neutral).

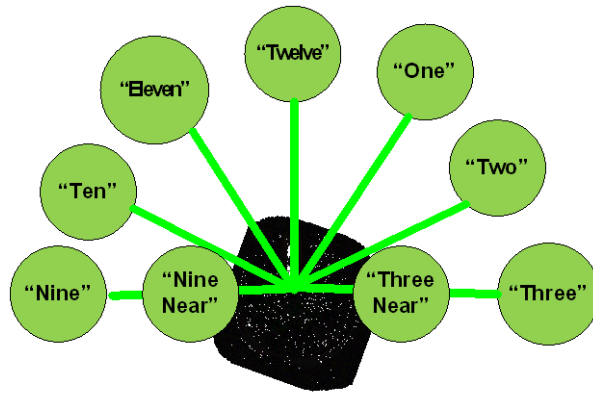


HRTF **REQUIRES** Stereo Headsets. If monaural headsets are used, the received audio will sound “distant” or

### 3.4.3 Audio Location

The pilot panel can control the locations for the six receive audio locations. Press and hold the HRTF button for > 1 second on the pilot’s panel until the HRTF button and all COM nomenclature start blinking green.

Rotate the COM receive volume knob, so the pointer indicates the approximate location of the desired location. A voice announcement will accompany the knob rotation with the clock positions. Received audio shall then be presented from that location. Repeat for other communication radios as desired.



**Figure 3-2 Spatial Audio Locations and Voice Annunciations**

Press the HRTF button again to exit the mode. The audio Controller will remember last state through power cycles.

### 3.4.4 Receiver Activity Indication (-RXI)

PAC45 systems (HUB45 Serial Number DH1069 and above) have a Receive Activity Indicator that flashes the *selected* receiver indicator when a signal is present on that receiver. This allows the user to spot an active radio, even if the volume is turned down. This function is set at the factory at the installer’s request and can be changed only at the factory.

### 3.5 Navaid Selection

Navigation receivers are selected in the same manner as the communication receiver by setting the knob associated with the desired navigational aid to the out position and rotate to adjust the receiver volume.



#### 3.5.1 Telephone control

The volume control selector connects the audio controller to either a Bluetooth-enabled cell phone or a wired cellular/satellite phone.

Pop out the volume control to select (answer or make phone call) and adjust the receive audio volume.



To hear the ringer of the Bluetooth phone, the volume control should be around the 12 o'clock position. Selecting the TEL switch in the OUT position is not required for Bluetooth connections but will be required if TEL is being used for satellite phone.

#### 3.5.2 Speaker Control (PAC45 050-045-0002, HUB45R 050-045-0102 only)

Press and hold the ICS button on either to pilot or copilot control head to toggle the output ON/OFF. When the speaker output is "ON", all alerts, unswitched inputs and all switched inputs selected by the pilot will be present. Intercom, telephone and music will never be present.

When the speaker output is "OFF", only alerts and unswitched inputs will be present



### 3.6 Intercom Operation (8)

#### 3.6.1 IntelliVOX® Intercom VOX-Squelch

No adjustment of the *IntelliVOX*® squelch control is necessary. Through individual signal processors, the ambient noise appearing in all microphones is constantly being sampled. Non-voice signals are blocked. When someone speaks, only their microphone circuit opens, placing their voice on the intercom.

The system is designed to block continuous tones; therefore, people humming or whistling in monotone may be blocked after a few moments.

For consistent performance, any headset microphone **must** be placed within ¼-inch of your lips, preferably against them. (ref: *RTCA/DO-214, 1.3.1.1 (a)*).

**NOTE**

It is also a good idea to keep the microphone out of a direct wind path. Moving your head through a vent air stream may cause the *IntelliVOX*® to open momentarily. This is normal. The *IntelliVOX*® is designed to work with normal aircraft cabin noise levels (70 dB and above). It loves airplane noise! Therefore, it may not recognize speech and clip syllables in a quiet cabin, such as in the hangar, or without the engine running. This is normal.

For optimum microphone performance, PS Engineering recommends installation of a Microphone Muff Kit from Oregon Aero (1-800-888-6910). This will not only optimize VOX performance, but will improve the overall clarity of *all* your communications.

| Manufacturer | Model       | Mic Muff™ Part Number |
|--------------|-------------|-----------------------|
| Bose         | Dynamic     | 90010                 |
|              | Electret    | 90015                 |
|              | M87 Dynamic | 90020                 |

|             |                     |       |
|-------------|---------------------|-------|
| David Clark | H10-30              | 90010 |
|             | H10-20, H10-40      | 90015 |
|             | H10-13.4            | 90015 |
| Lightspeed  | All                 | 90015 |
| Peltor      | 7003                | 90010 |
|             | 7004                | 90015 |
| Pilot       | 11-20 & 11-90       | 90015 |
| Sennheiser  |                     | 90015 |
| Telex       | Airman 750, Echelon | 90015 |
|             | AIR3000             | 90010 |

**Table 3-1 Mic Muff™ Part Numbers**

### 3.6.2 Push to talk intercom (PTT ICS)

Pressing the intercom volume knob (ICS VOL) will place the user assigned to that control head into the Push-to-talk (PTT for Intercom use) mode. This will disable the voice activation (VOX) and require that the external push to talk intercom buttons for the position be used to speak on the intercom.

Push the knob again and the user toggles back to voice activation. The mode is shown by the green indication in the text.



### 3.6.3 Intercom Volume Control

The intercom volume control knob adjusts the loudness of the intercom for the intercom station(s) connected to the audio controller panel. It has no effect on selected radio levels, or music input levels.

In a single control panel installation, the volume control adjusts pilot, copilot, and any passengers.

In 2-control (pilot & copilot) panel installation, the pilot panel controls pilot intercom volume only, copilot panel controls copilot and passenger intercom volume. In a 2-panel installation with one crew panel and one mission panel, the crew volume control controls the intercom volume for pilot and copilot, and the mission/observer panel controls passenger intercom volume.

In a 3-control panel installation, the pilot, copilot, and mission panel volume control adjusts the intercom associated with that control head.

#### 3.6.3.1 Monaural headsets

The pilot and copilot positions work with stereo or mono headsets. However, MultiTalker will not be presented correctly unless stereo headsets are used, and oriented correctly on the head, left and right.



**NOTE: For the full effect of MultiTalker Dimensional Sound, stereo headsets *must be used*, and the left/right orientation observed.**



Some *passenger* headsets are connected in parallel. Therefore, if a monaural headset is plugged in to a PAC45 Stereo installation, one channel may be shorted. Although no damage to the unit will occur, all passengers with stereo headsets will not hear one channel, unless they switch to the “MONO” mode on their headset.



**NOTE: Mono headsets that short the tip and ring (i.e. older models) will introduce some audio distortion when used. Modern, stereo headsets are recommended in all positions.**

### 3.6.4 Intercom Modes

#### 3.6.4.1 Single Unit/Control Head

The “ICS” pushbutton switch on the panel provides the selection of the intercom modes

The intercom mode defaults to “ALL” at power up. Then the button cycles through the intercom modes, from top to bottom, then bottom to top as: ISO, ALL CRW, ALL. A green indicator shows which mode is currently active.

**ISO:** The pilot is isolated from the intercom and is connected only to the aircraft radio system. He will hear the aircraft radio reception (and sidetone during radio transmissions). Copilot will have radios, intercom and music. Passengers will have intercom and music.

**ALL:** All parties will hear the aircraft radio, intercom and music. During any radio or intercom communications, the music volume automatically decreases. The music volume increases gradually back to the original level after communications have been completed.

**CREW:** Pilot and copilot are connected on one intercom channel and have exclusive access to the aircraft radios.



#### 3.6.4.2 Remote ICS Mode Control (P454 connector pin 18)

An optional external switch can act as a remote intercom mode selector. Pressing the switch will increment the intercom mode selector from ISO-ALL-CRW-ALL, etc. each time the button is pressed.

### 3.7 Bluetooth® connection

The PAC45 has an internal Bluetooth module (FCC ID: QQQWT32AE), no external boxes required. The audio controller is always “discoverable,” so you just need to search for the PAC45 from your Bluetooth-equipped phone or music source. Default access code is not required. Once the PAC45 has been “paired” with your Bluetooth device, the TEL distribution will act as described in § [3.7.2](#).

#### 3.7.1 Pairing and unpairing Bluetooth devices

The PAC45 can be paired with up to eight individual devices, but will only connect to one at a time. When that number is exceeded, the PAC45 will drop a device to allow the new device to be added.

Once paired, the audio controller should connect automatically.

*Hint, if your devices are not recognized by the PAC45, you may need to cycle Bluetooth on or off from your device. If that does not help, you may need to reset the Bluetooth module, Press and hold HRTF and ICS buttons for more than three (>3) seconds. Then “forget” the audio controller from your device, and repair.*

#### 3.7.2 Bluetooth® Telephone Mode

The PAC45 serves as a full duplex interface for telephone systems such as portable cellular phones with Bluetooth connectivity.

**Warning:**

United States FCC Regulations contained in 47 CFR § 22.925 currently contain prohibition on airborne operation of cellular telephones. "Cellular telephones installed in or carried aboard airplanes, balloons or any other type of aircraft must not be operated while such aircraft are airborne (not touching the ground). When any aircraft leaves the ground, all cellular telephones on board that aircraft must be turned off."

To answer an incoming call, or initiate a call from the PAC45, select the TEL volume control to the out position.

In **ALL** intercom mode, all crew and passengers will be heard on the phone when they speak.

In **CREW** mode, the pilot and copilot are connected to the telephone.

In **ISO** intercom mode, when the PAC45 is in the **TEL** mode, the pilot position is in the "Phone Booth." Only the pilot will hear the telephone, and only he will be heard.

**NOTE**

PS Engineering does not guarantee compatibility with personal cellular telephones.

### 3.7.2.1 Bluetooth Reset

To reset the Bluetooth module, clearing out the connected devices, press HRTF and ICS for more than three seconds.

### 3.7.3 Music Muting Control (Serial Number GH01139 and above only)

The PAC45 incorporates PS Engineering's trademark "SoftMute. The SoftMute™ circuit will mute the music whenever there is conversation on the radio or the intercom. When that conversation stops, the music returns to the previous level comfortably, over a second or so.

Holding down ACK button for three (3) seconds will turn the music muting on/off.

When in mute off mode, the intercom, radio & PTT will not mute the music. The music muting will reset to mute on mode at each power cycle. Any control head will switch the muting on or off for *all* users.



## 3.8 Wired Satcom/Cell Phone input

The PAC45 can accommodate a wired telephone input as well as a Bluetooth connection. This operates the same as the Bluetooth Telephone ([see §3.7.2](#))



### 3.9 Dual Control Panel Operation/Pilot & Copilot

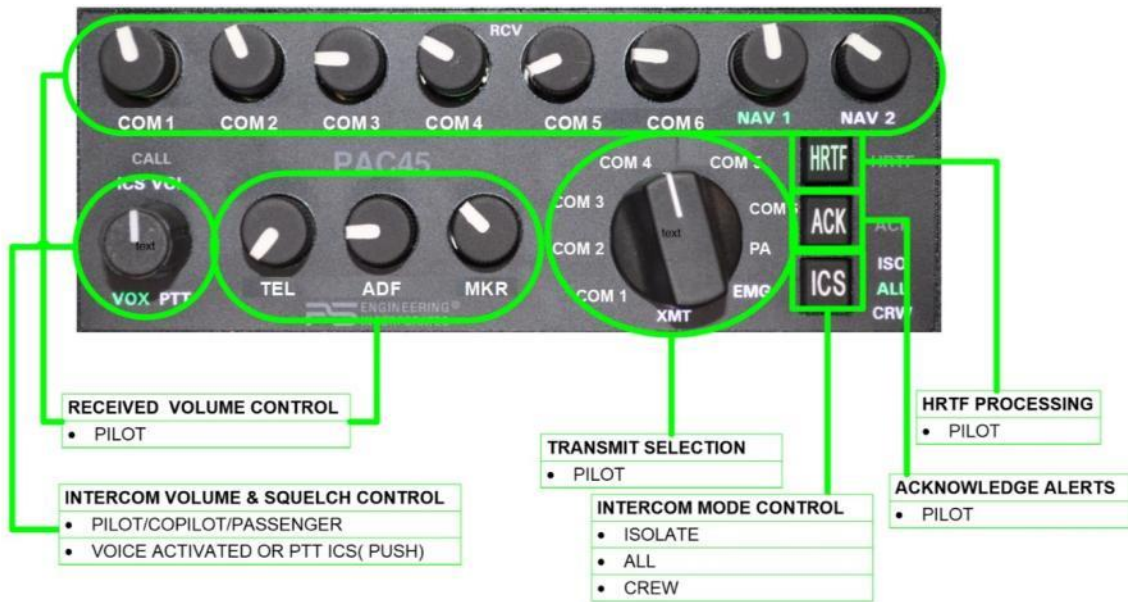


Figure 3-3 Pilot Control Head, Dual configuration



Figure 3-4 Copilot Audio controller, Dual Configuration CTL45P

#### 3.9.1.1 Intercom Operation, Two (Pilot, Copilot) Control Heads

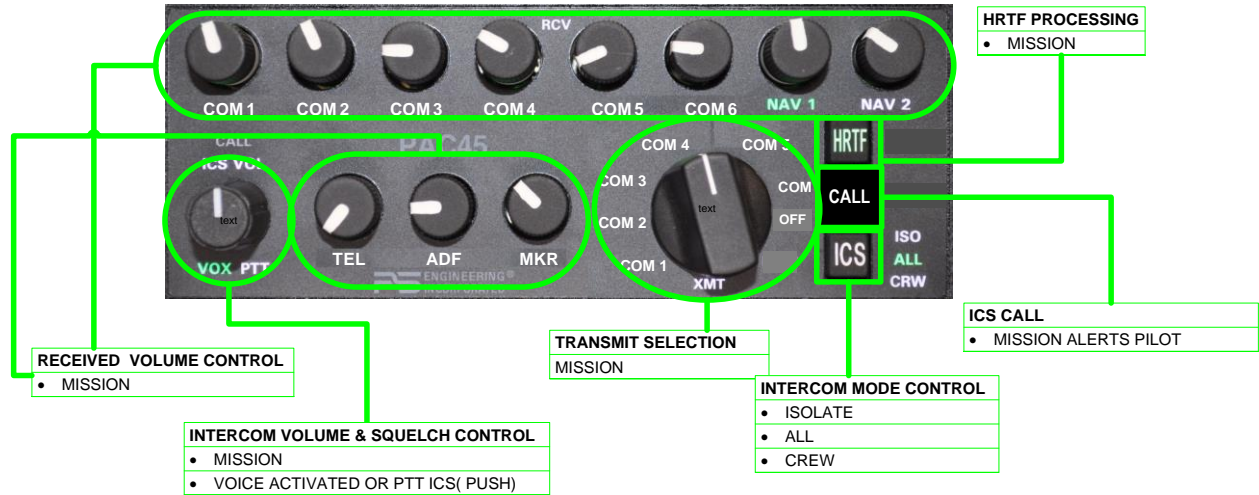
If two control heads are used, the following rules apply:

- System defaults to ALL-ALL at power up.
- Either panel can select ISO, and be removed from intercom, while the other remains with the passengers.
- Either panel can select CRW, and place both panels in Crew mode

- Either panel can select ALL and add everybody to the intercom and radio

### 3.10 Observer/Mission Control Panel Operation

Some configurations utilize a CTL45M, Observer/Mission control head.



**Figure 3-5 Third (Mission/Observer) Control Head Configuration**

The CTL45M has the same operation as the crew controller, except this controller cannot make public address announcements. The CTL45M has an ICS CALL button to alert the crew that the observer positions(s) want to be on the intercom with the crew.

#### 3.10.1.1 Intercom Operation, Two Control Heads (Pilot, Mission)

In this configuration, the pilot and copilot crew positions have one control head (CTL45P) and the Mission personnel have another, CTL45M.

- System defaults to ALL -ALL at power up.
- Either panel can select ISO, and be removed from the intercom.
- The crew panel can select CRW, and place their panel in Crew mode, while the observer audio controller is forced to ISO.
- The crew panel can select ALL and add everybody to the intercom.
- The Mission Observer panel can select ISO, and then select ALL, unless a crew panel has selected ISO or CREW. If the crew audio controller has selected ISO or CRW, the mission observer panel must use the intercom CALL function to be added to the intercom

#### 3.10.1.2 Intercom Operation, Three Control Heads (Pilot, Copilot & Mission)

If three control heads are used, the following rules apply:

- System defaults to ALL-ALL-ALL at power up.
- Any panel can select ISO, and be removed from the intercom.
- Either pilot or copilot panel can select CRW, and place both panels in Crew mode, while the observer audio controller is forced to ISO.
- Either pilot or copilot panel can select ALL and add everybody to the intercom.
- The Mission Observer panel can select ISO, and then select ALL, unless a pilot or copilot has selected ISO or CREW.

With the CTL45M installed, the observer/mission personnel can isolate their audio feed from the crew by pressing the ICS button. When the CTL45M is in ISO mode, the observer/passengers will have intercom among themselves, and be able to use the selected radios.

If the flight crew selects ISO or Crew modes, the CTL45M will automatically enter the ISO mode, and will not change modes unless the crew changes their state. If the observer personnel desire to communicate with the crew, pressing "CALL" will activate an ICS call light and a chime in the crew headsets.

### 3.10.2 Dual Audio HUB45 Intercom Operation (MOD #10 Units Only)

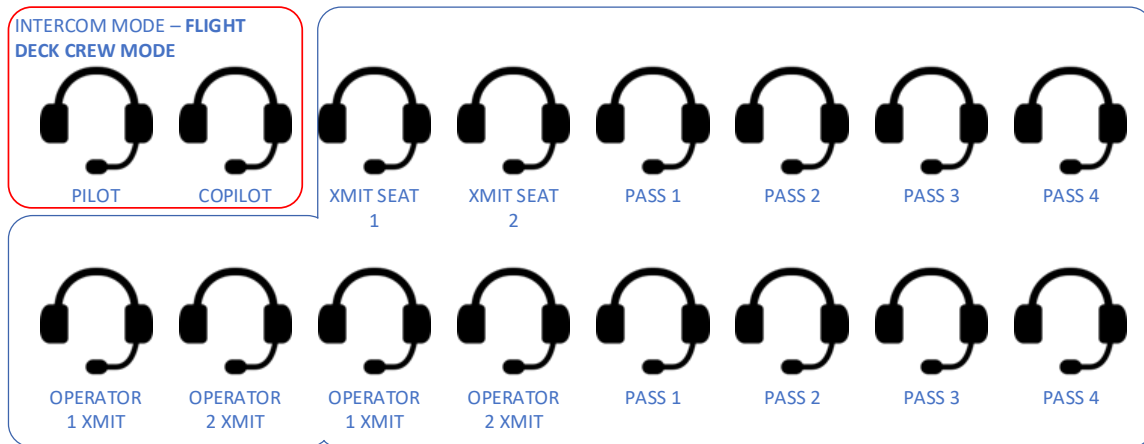
This section describes the intercom modes in a dual hub system. For clarity, we will designate one system (HUB45#1) as flight crew, and the other (HUB45 #2) mission operators.

- ALL – When BOTH systems are in ALL intercom mode, all intercom stations will have radio and intercom audio.



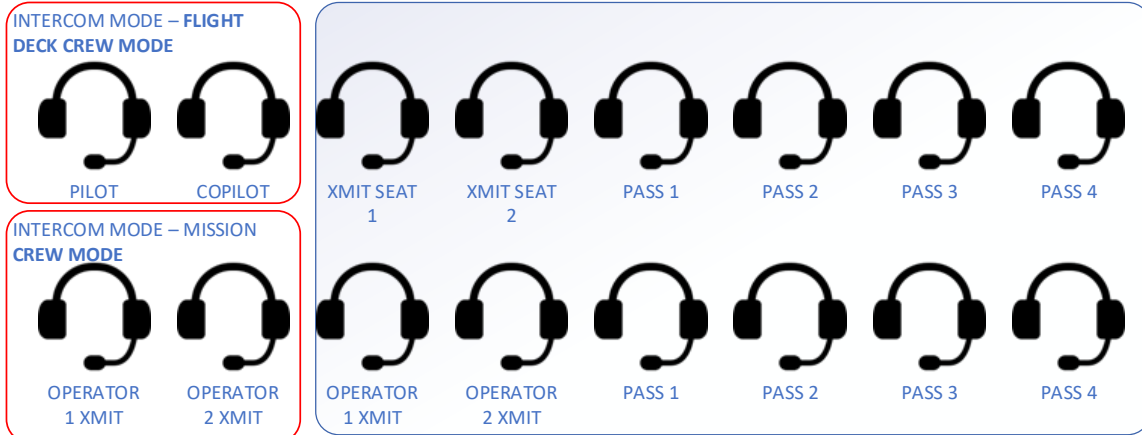
**Figure 6 - Dual HUB, ALL Mode**

- CREW – When the Flightcrew systems are in CREW mode, the Pilot and Copilot are isolated from the rest of the aircraft.



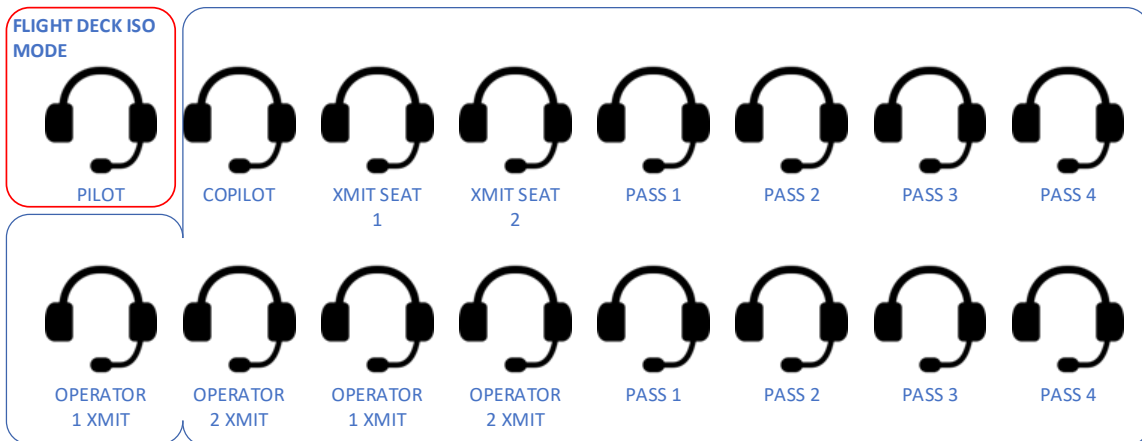
**Figure 7 - Dual HUB, Flight CREW Mode**



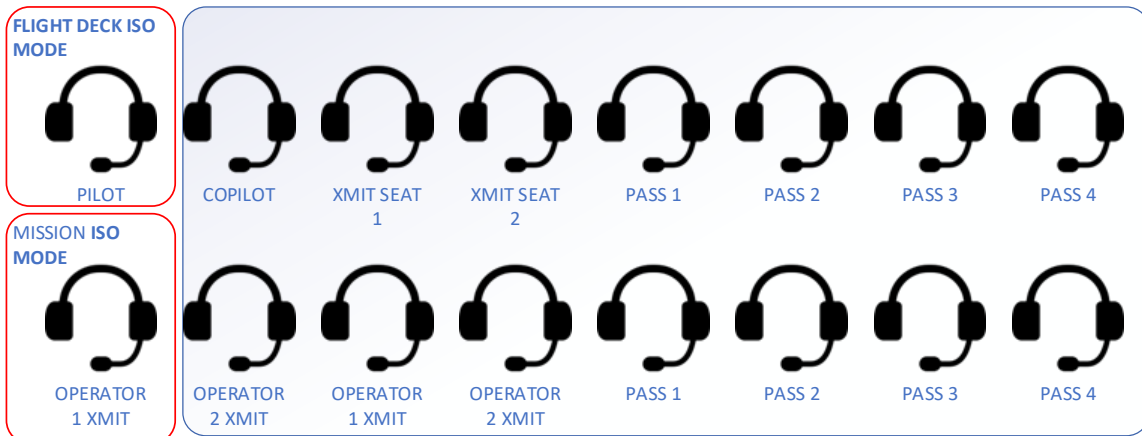


**Figure 8 – Both systems in CREW Mode**

When the flight crew control head is in Isolate, the pilot is separated from the rest of the aircraft.



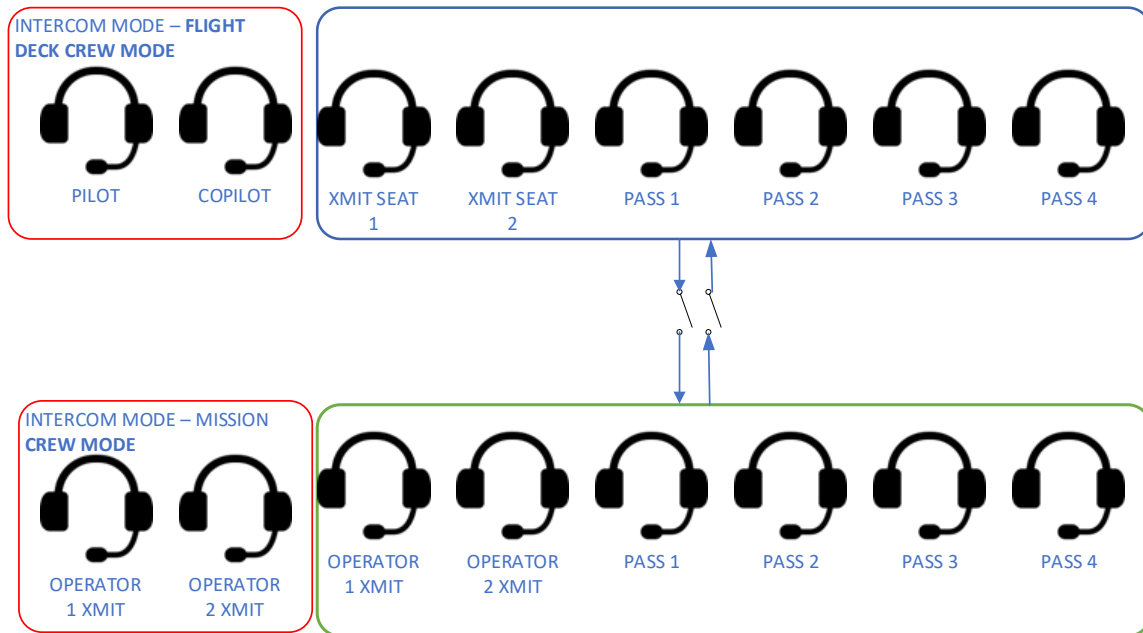
**Figure 9 – Flight Crew Pilot ISO mode**



**Figure 10 – Both systems placed into ISOLATE mode**

### 3.10.2.1 Dual system isolation

If complete separation of the passengers is desired, a switch can be installed in the tie-lines between the HUB45s (see §2.4.11.6)



### 3.11 Alert Audio

The PAC45 incorporates an independent alert audio system that can store three audio messages recorded by the user and played back when triggered by an external source. Once triggered, the alert audio will continue until the ACK button (front panel or external) on the CTL45 control panel is pushed, or the trigger input returns to normal. Edge-triggered alerts will play 3 times or until ACK is pushed, whichever occur first.

The PAC45 system can store three audio alerts, default audio is stored at the factory. These are “Master Caution,” “Alert,” and a simple chime.

#### 3.11.1 Storing Alert Audio

You must record all three when the unit is in audio program mode. You cannot change *only one at a time*. If you wish to replace just one message, we recommend you write down all the messages before starting the procedure.

To record messages from the pilot’s headset:

1. Press & Hold “ACK” and “ICS” buttons until a chime is heard in the headset, and then *release* the buttons.
2. COM1 will blink, to indicate the recording of ALERT #1.
3. Start speaking message.
4. When finished with Alert #1, press the “ACK”.
5. Now COM2 will blink, to indicate the recording of ALERT #2.
6. Speak message.
7. When finished with Alert #2, press the “ACK”

8. Now COM3 blinks, to indicate the recording of ALERT #3.
9. Speak message.
10. When finished with Alert #3, press the “ACK”
11. A chime indicates that recording is now finished.

*NOTE: If ACK is not pressed to indicate end of recording, it will record for five seconds, and then advance to next alert. After all three time slots are timed out, the PAC45 will exit the alert re-recording mode.*

### 3.11.2 Soft-Key Functions

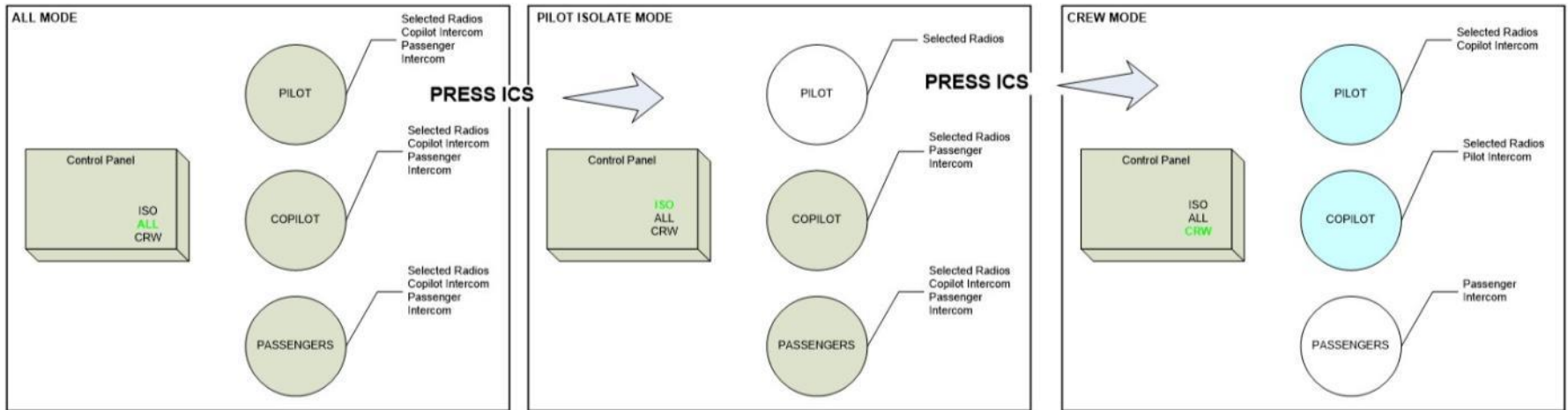
The PAC45 System has some secondary functions using the mode select buttons. A long press is three (3) seconds.

| <b>Long (1 Sec.) Press button</b> | <b>Action</b>  |
|-----------------------------------|--|
| HRTF                              | 3D audio program mode (press on pilot control head only) |
| ACK + ICS                         | Used for programming alerts                              |
| ACK                               | Used for activating music mute override                  |
| ICS                               | Speaker On/Off   |
| HRTF + ICS                        | Bluetooth® module reset                                  |
| HRTF + ACK                        | Green dimmer/lighting setup                              |

### 3.12 Intercom Operation Block Diagrams

These block diagrams illustrate the audio distribution for intercom and radios in four different configurations, single panel, dual panel pilot/copilot, dual panel pilot-copilot/observer, and three control head.

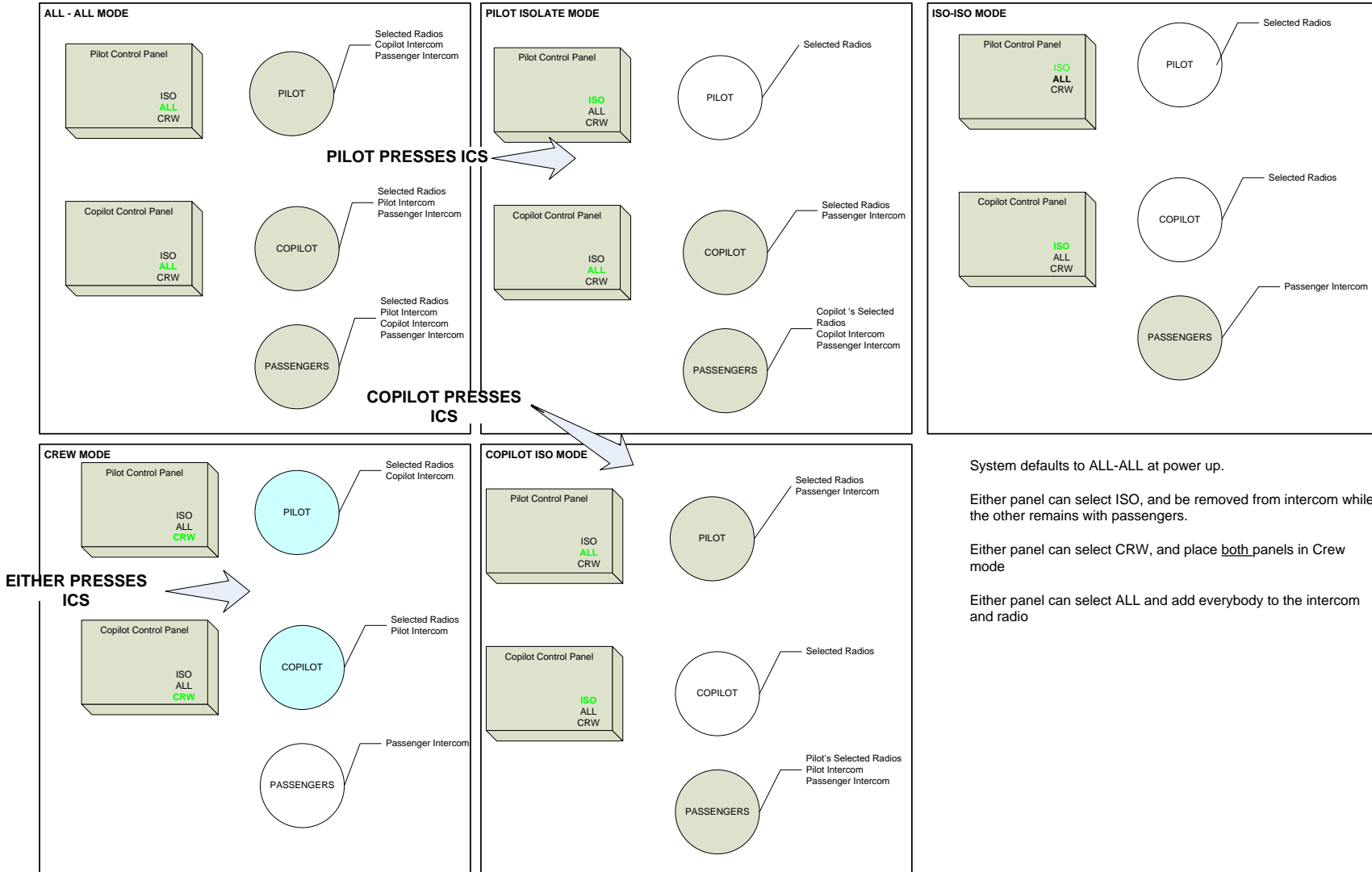
#### 3.12.1 Single Control Panel



#### 3.12.2 Dual Control Head, Pilot CTL45P and Copilot CTL45P

**PS Engineering**  
**PAC45 Audio Selector Panel and Intercom System**  
**Installation and Operator's Manual**

**DUAL CONTROL HEAD INTERCOM MODES**



System defaults to ALL-ALL at power up.

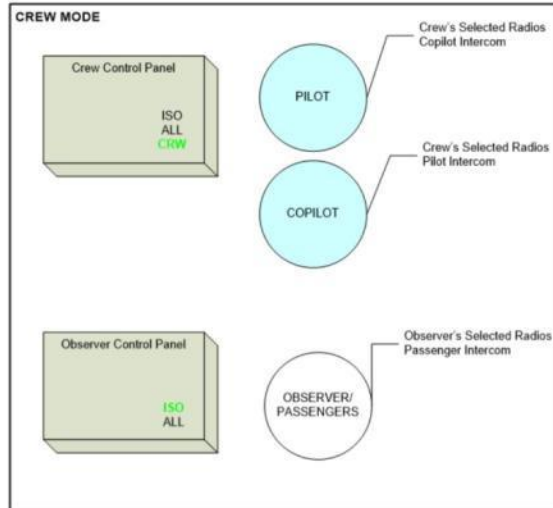
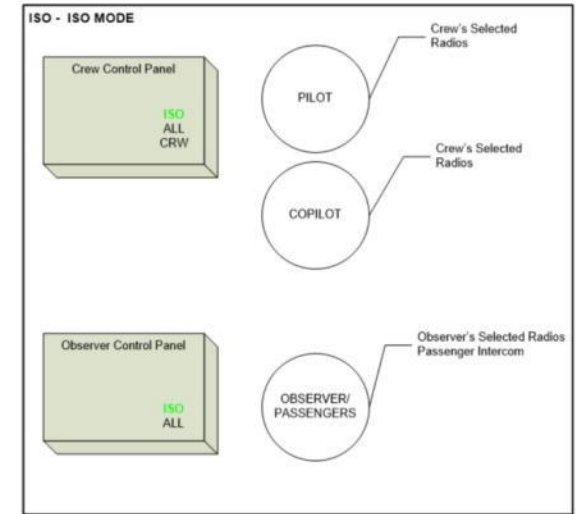
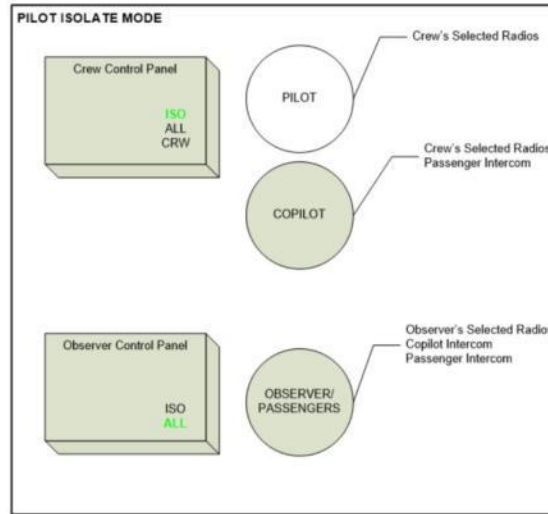
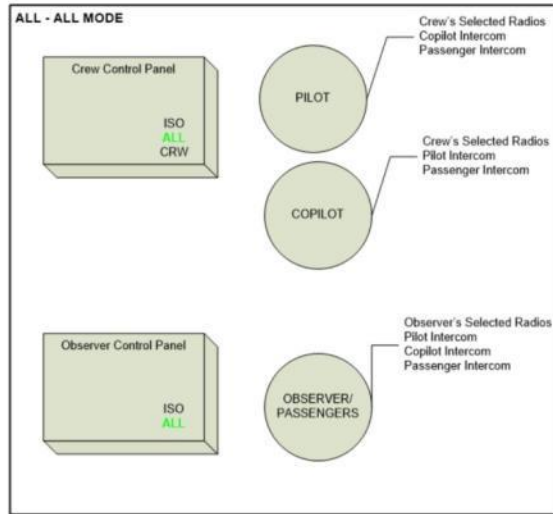
Either panel can select ISO, and be removed from intercom while the other remains with passengers.

Either panel can select CRW, and place both panels in Crew mode

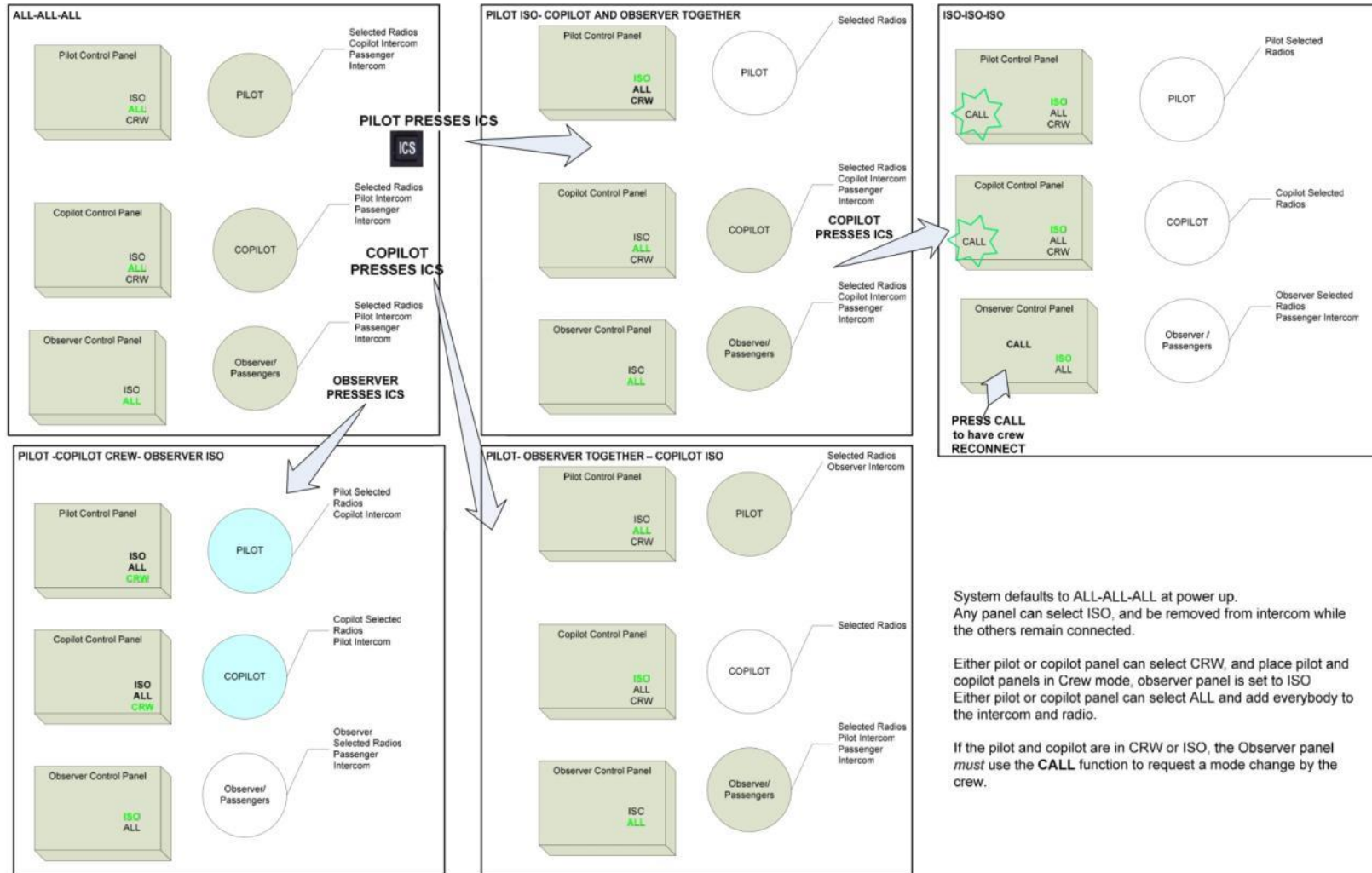
Either panel can select ALL and add everybody to the intercom and radio

### 3.12.3 Dual Control Head Pilot & Copilot CTL45P plus Observer CTL45M

**DUAL CONTROL HEAD – CREW AND OBSERVER**



### 3.12.4 Three Control Head, Pilot CTL45, Copilot CTL45P and Mission Observer CTL45M



System defaults to ALL-ALL-ALL at power up.  
 Any panel can select ISO, and be removed from intercom while the others remain connected.

Either pilot or copilot panel can select CRW, and place pilot and copilot panels in Crew mode, observer panel is set to ISO  
 Either pilot or copilot panel can select ALL and add everybody to the intercom and radio.

If the pilot and copilot are in CRW or ISO, the Observer panel *must* use the CALL function to request a mode change by the crew.

## **Section IV – Warranty and Service**

### **4.1 Warranty**

In order for the factory warranty to be valid, the installations in a certified aircraft must be accomplished by an FAA- (or other ICAO agency) certified avionics shop and authorized PS Engineering dealer. If the unit is being installed by a non-certified individual in an experimental aircraft, a factory-made intercom harness must be used for the warranty to be valid.

PS Engineering, Inc. warrants this product to be free from defect in material and workmanship for a period of two (2) years from the date of sale. During the first **twelve (12) months** of the two-year warranty period, PS Engineering, Inc., at its option, will send a replacement unit at our expense if the unit should be determined to be defective after consultation with a factory technician. For the remaining **twelve (12) months** of the two-year warranty period, PS Engineering, Inc., at its option, will send a similar replacement unit at the customers' expense if the unit should be determined to be defective after consultation with an authorized PS Engineering dealer.

All transportation charges for returning the defective units are the responsibility of the purchaser. All domestic transportation charges for returning the exchange or repaired unit to the purchaser will be borne by PS Engineering, Inc. The risk of loss or damage to the product is borne by the party making the shipment, unless the purchaser requests a specific method of shipment. In this case, the purchaser assumes the risk of loss.

This warranty is not transferable. Any implied warranties expire at the expiration date of this warranty. PS Engineering SHALL NOT BE LIABLE FOR INCIDENTAL OR CONSEQUENTIAL DAMAGES. This warranty does not cover a defect that has resulted from improper handling, storage or preservation, or unreasonable use or maintenance as determined by us. This warranty is void if there is any attempt to disassemble this product without factory authorization. This warranty gives you specific legal rights, and you may also have other rights, which may vary from state to state. Some states do not allow the exclusion of limitation of incidental or consequential damages, so the above limitation or exclusions may not apply to you.

All items repaired or replaced under this warranty are warranted for the remainder of the original warranty period. PS Engineering, Inc. reserves the rights to make modifications or improvements to the product without obligation to perform like modifications or improvements to previously manufactured products.

### **4.2 Factory Service**

The units are covered by a two-year limited warranty. See warranty information. Call PS Engineering, Inc. at (865) 988-9800 before you return any unit. This will allow the service technician to provide any other suggestions for identifying the problem and recommend possible solutions.

After discussing the problem with the technician and you obtain a Return Authorization Number, ship product to:

PS Engineering, Inc.

Attn: Service Department

9800 Martel Rd

Lenoir City, TN 37772

(865) 988-9800 FAX (865) 988-6619

Email: support@ps-engineering.com

**Units that arrive without an RMA number, or telephone number for a responsible contact, will be returned un-repaired. PS Engineering is not responsible for items sent via US Mail.**



## Appendix A – PAC45 Installation Drawings

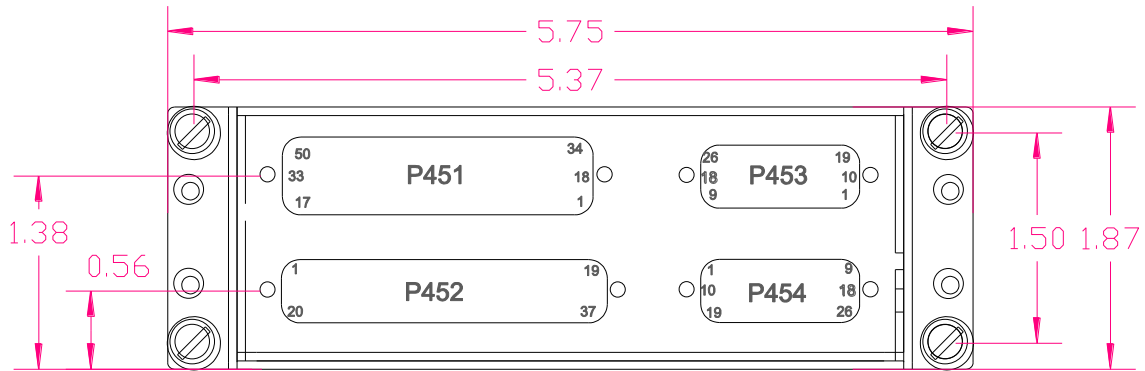


Figure 5-1 – PAC45 Rear/Connector View (not to scale)

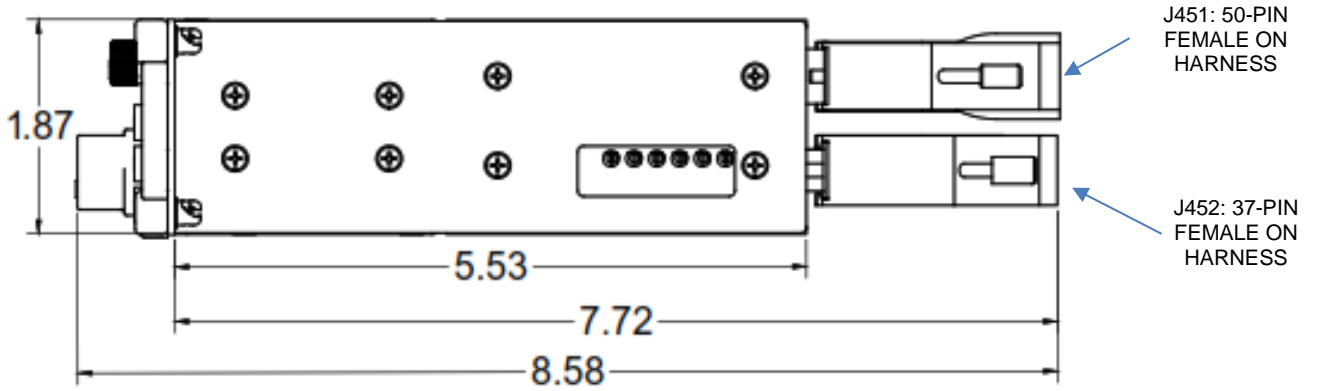


Figure 5-2 – PAC45 Side View

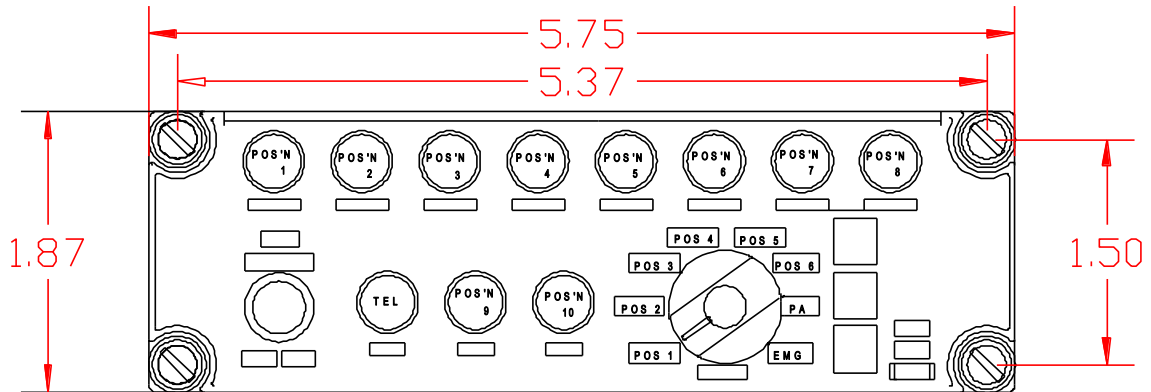


Figure 5-3 - PAC45/CTL45 Front View

PS Engineering  
PAC45 Audio Selector Panel and Intercom System  
Installation and Operator's Manual

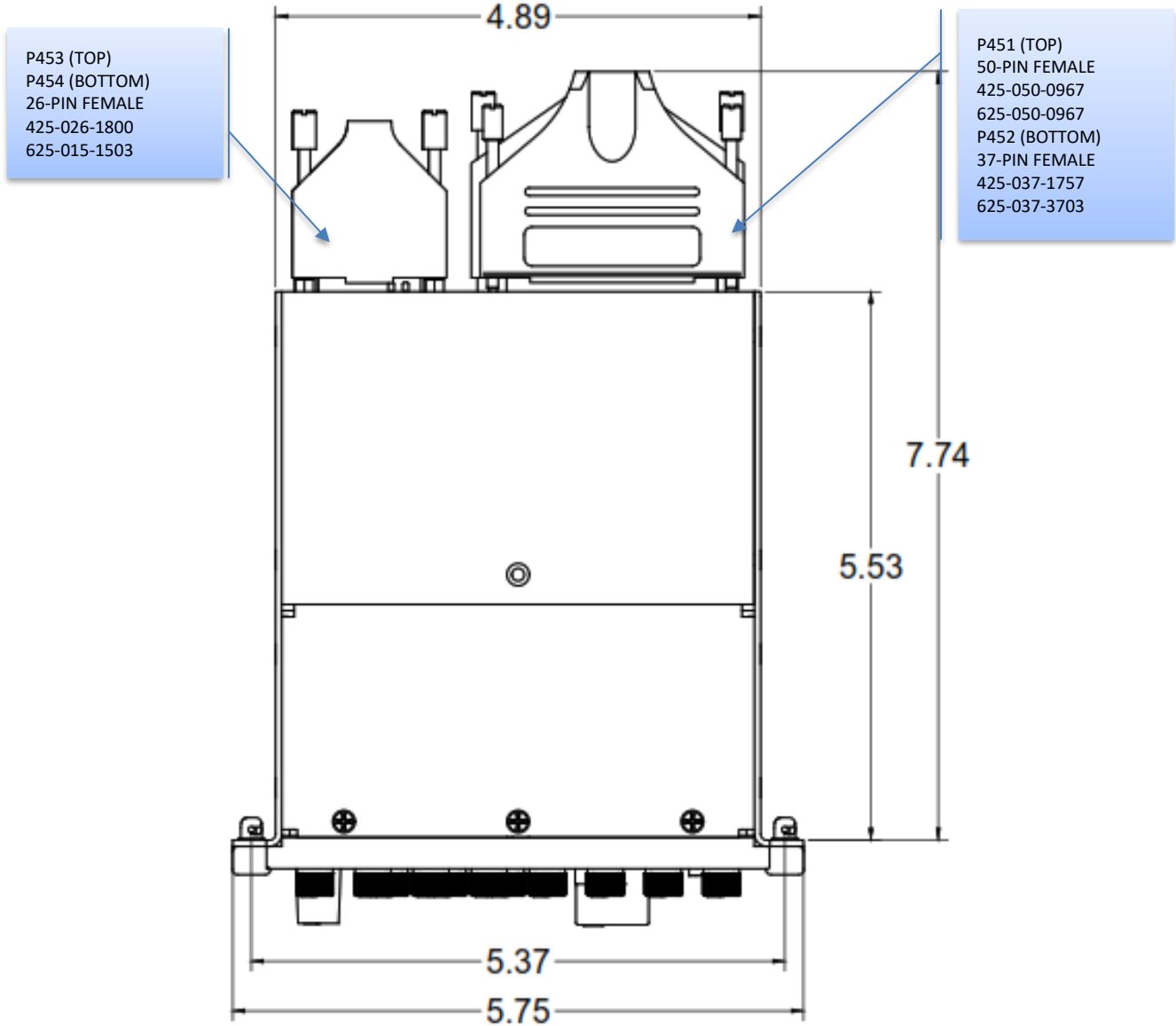


Figure 5-4 PAC45 Overall

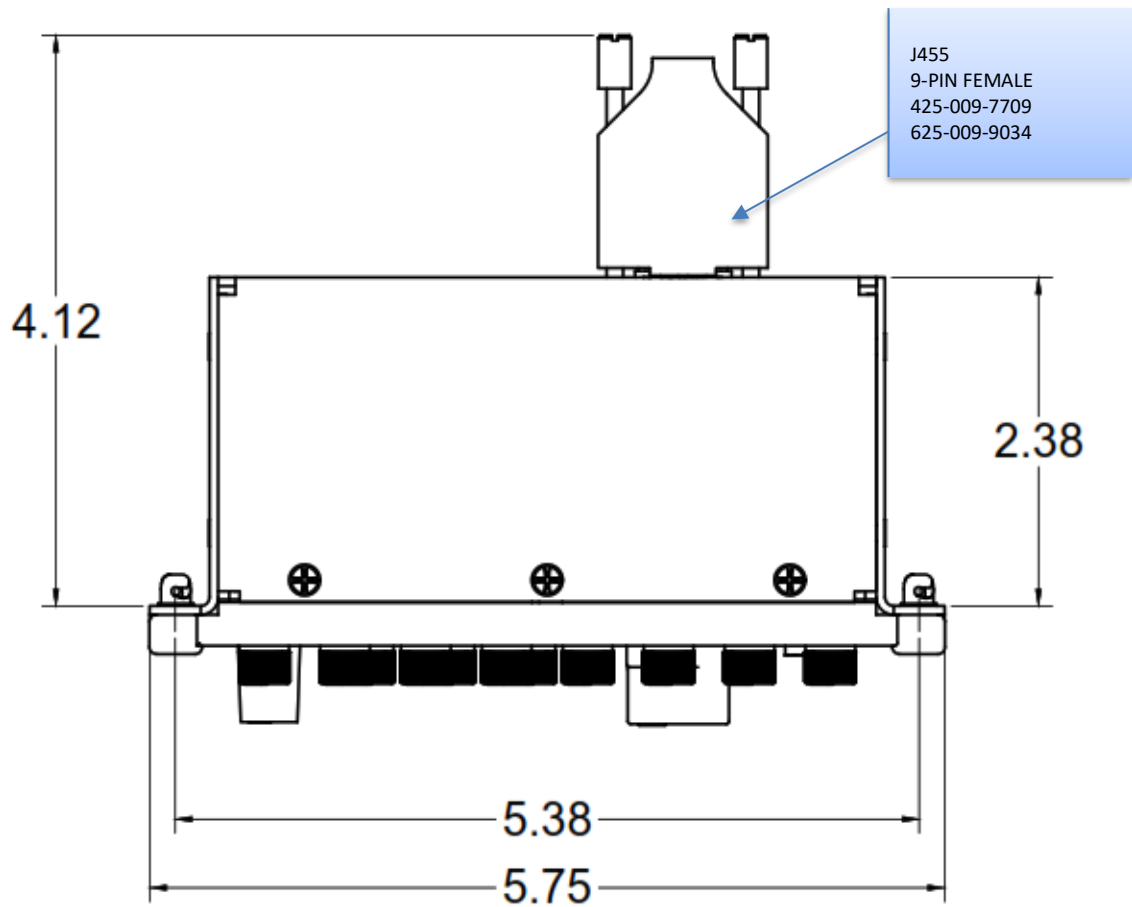
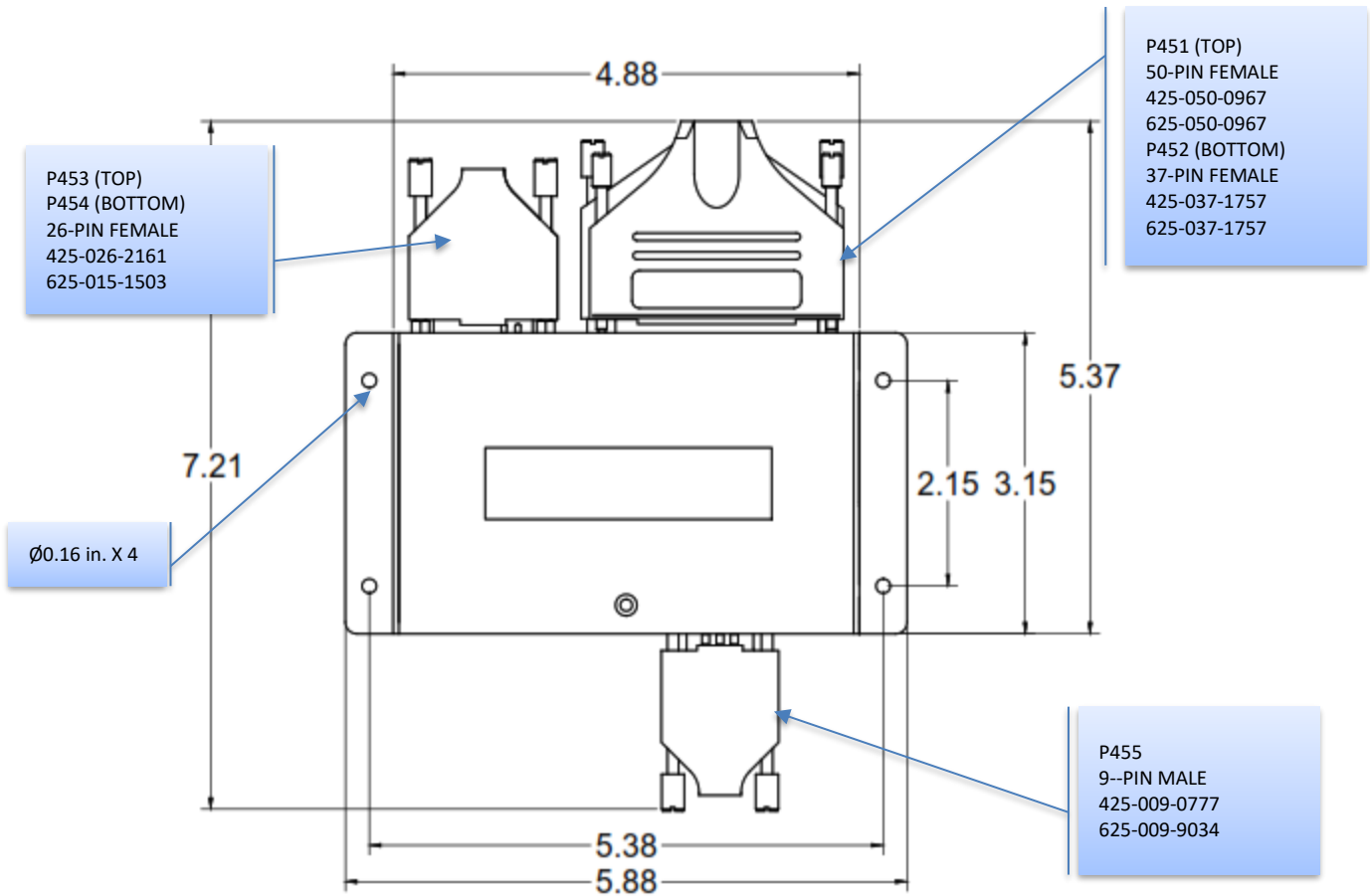
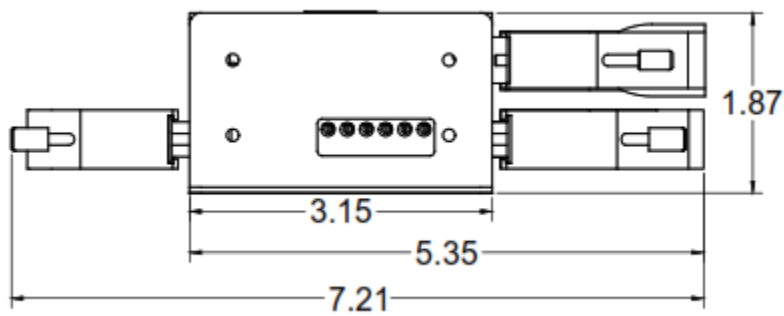


Figure 5-5 CTL45

**PS Engineering**  
 PAC45 Audio Selector Panel and Intercom System  
 Installation and Operator's Manual

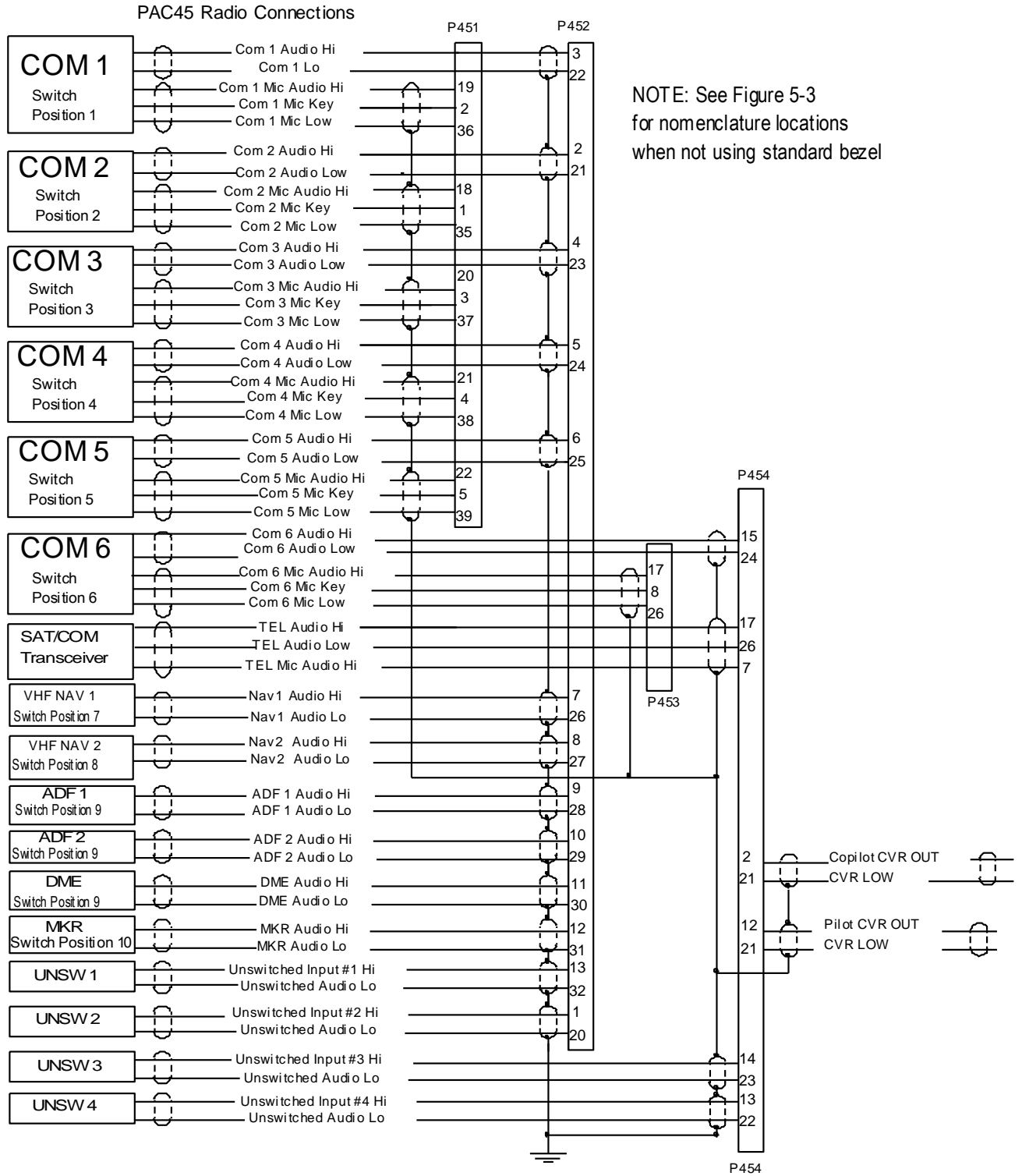


**Figure 5-6 HUB45R Top View**

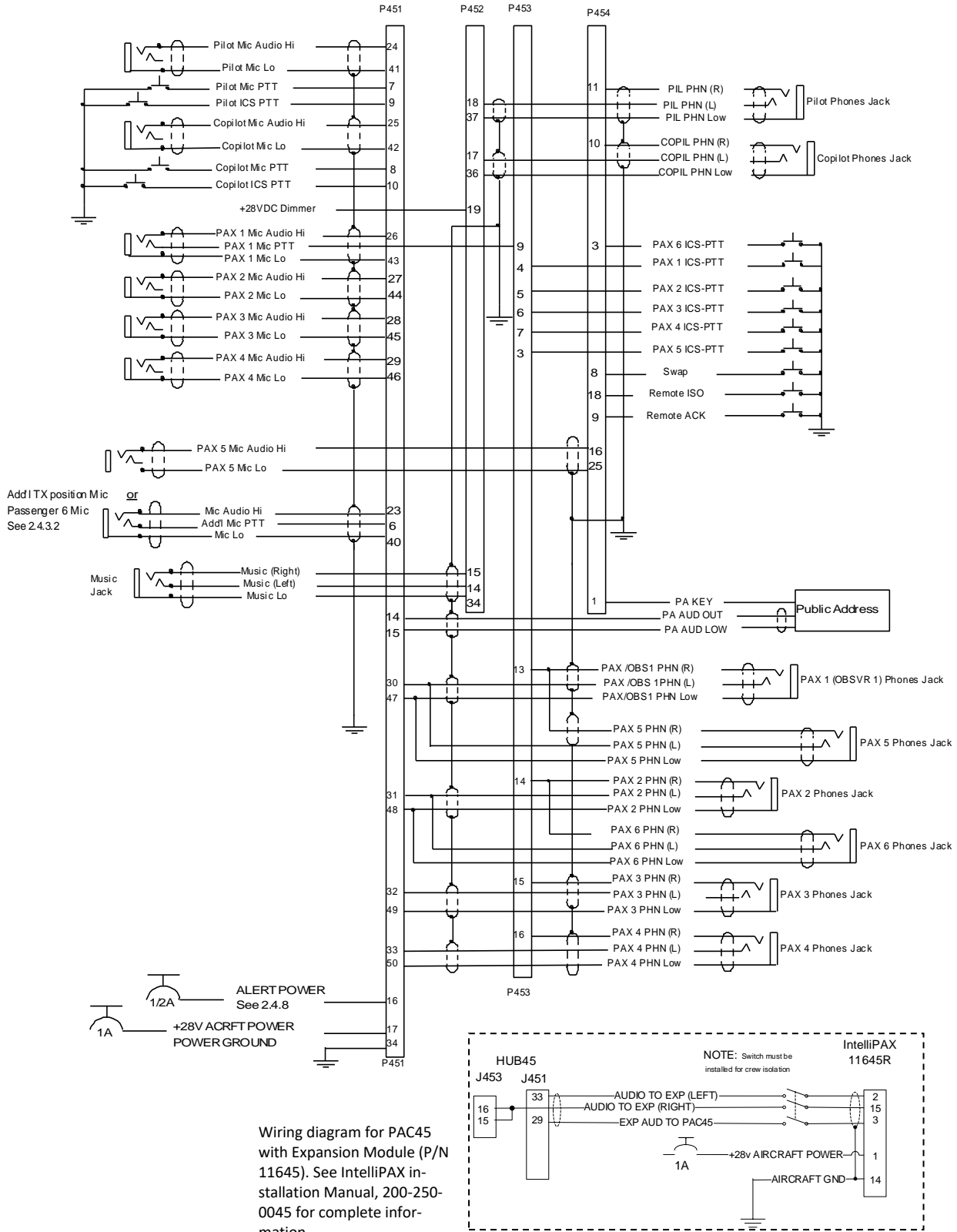


**Figure 5-7 - HUB45R Side View**

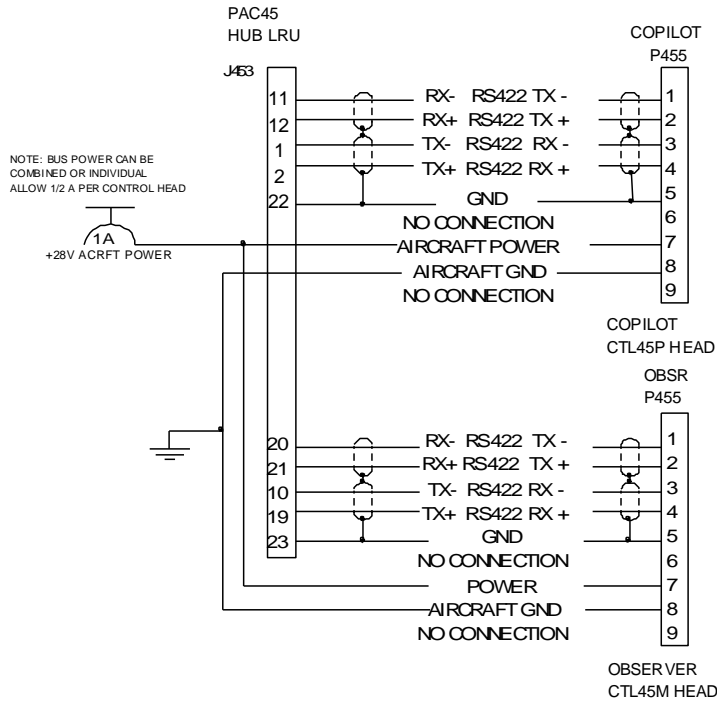
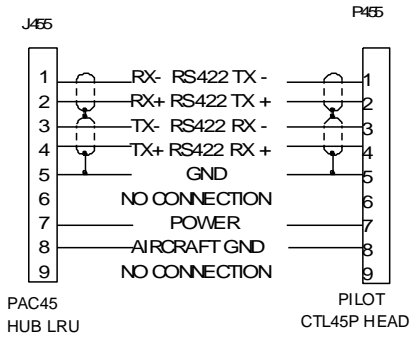
## Appendix B – Radio Interconnect Wiring



## Appendix C – Intercom Interconnect Wiring

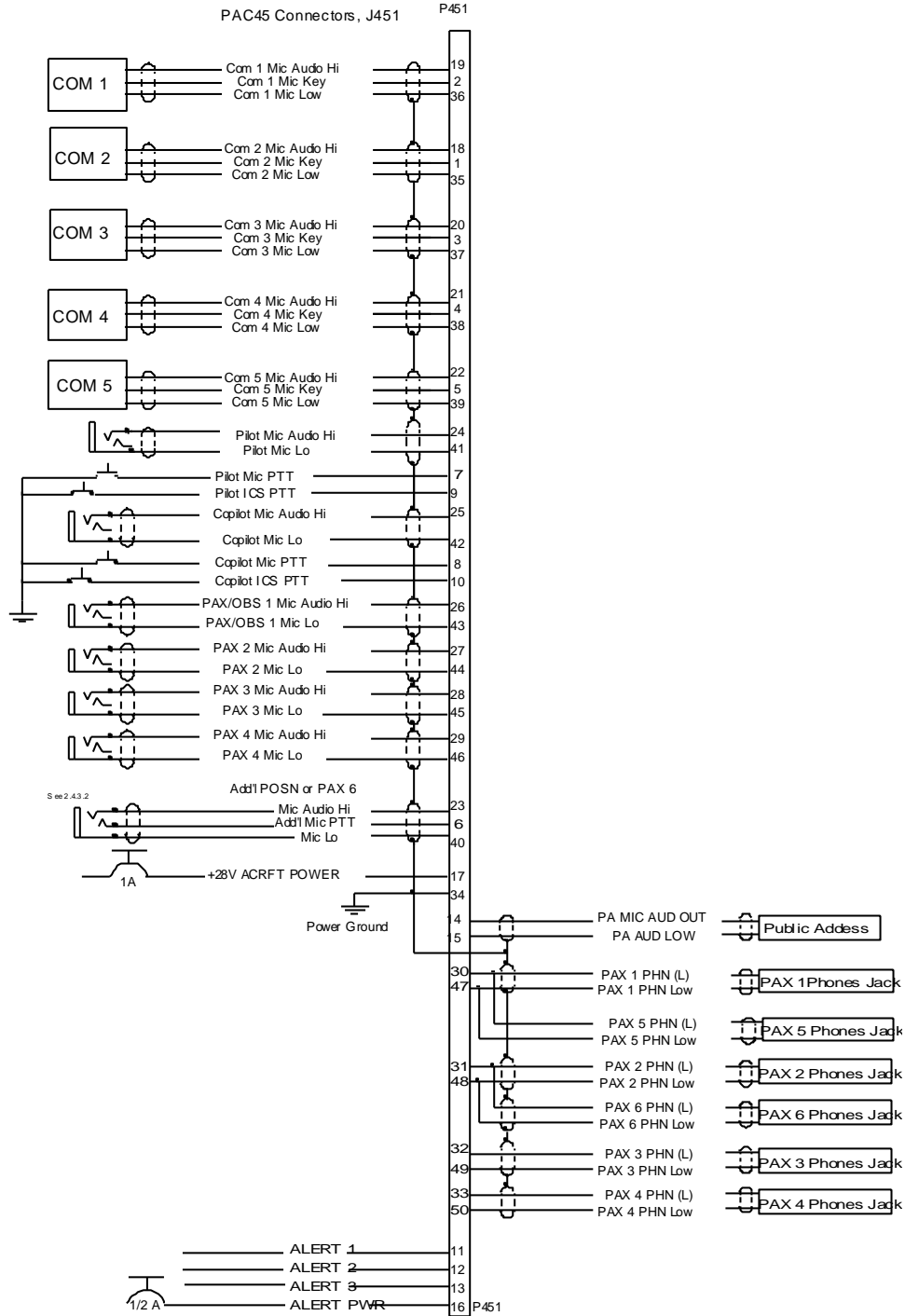


## Appendix D – Control Head Interconnect Wiring



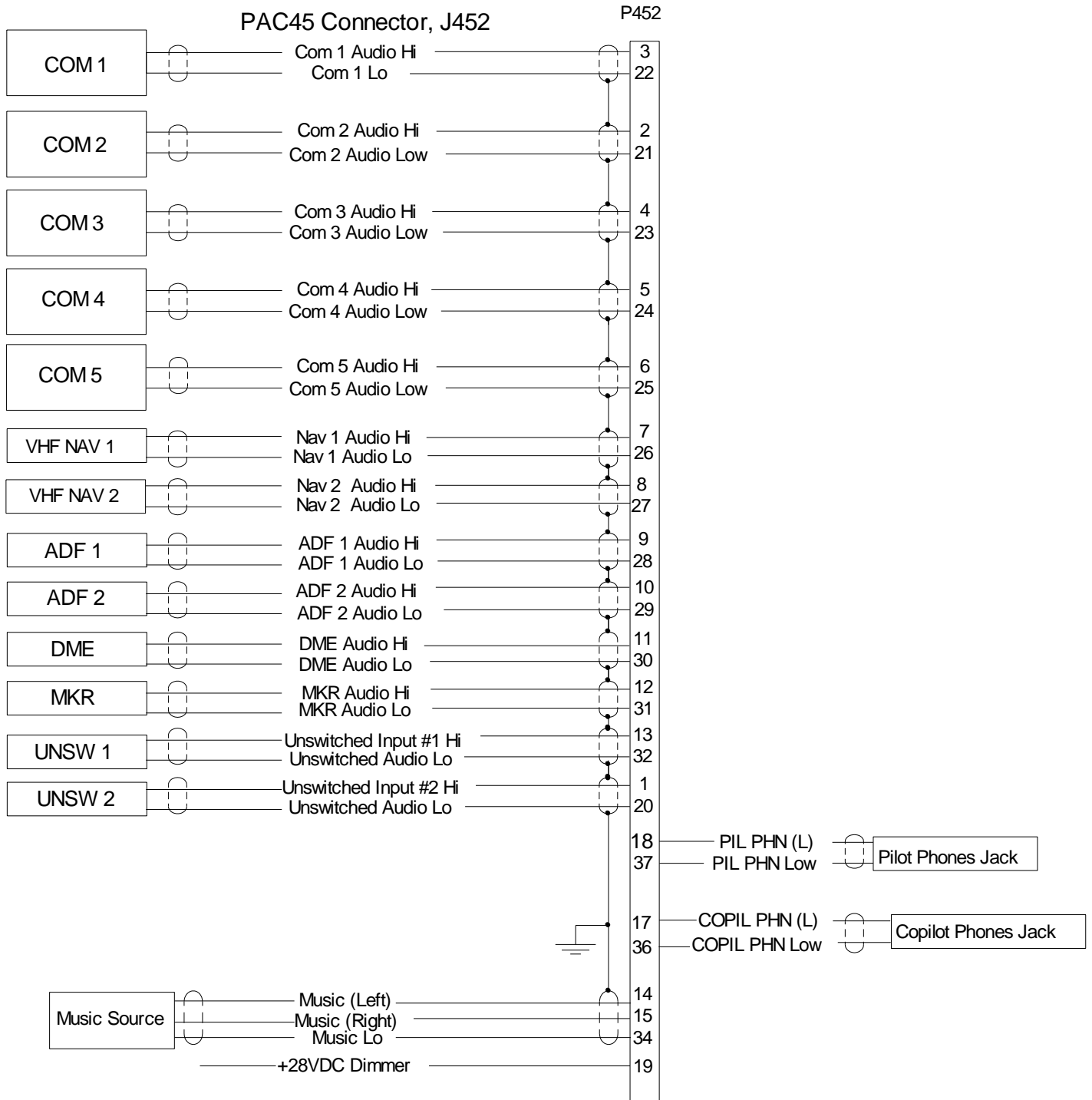
## Appendix E, Unit Connector Wiring Reference

### 9.1 J451 Connections

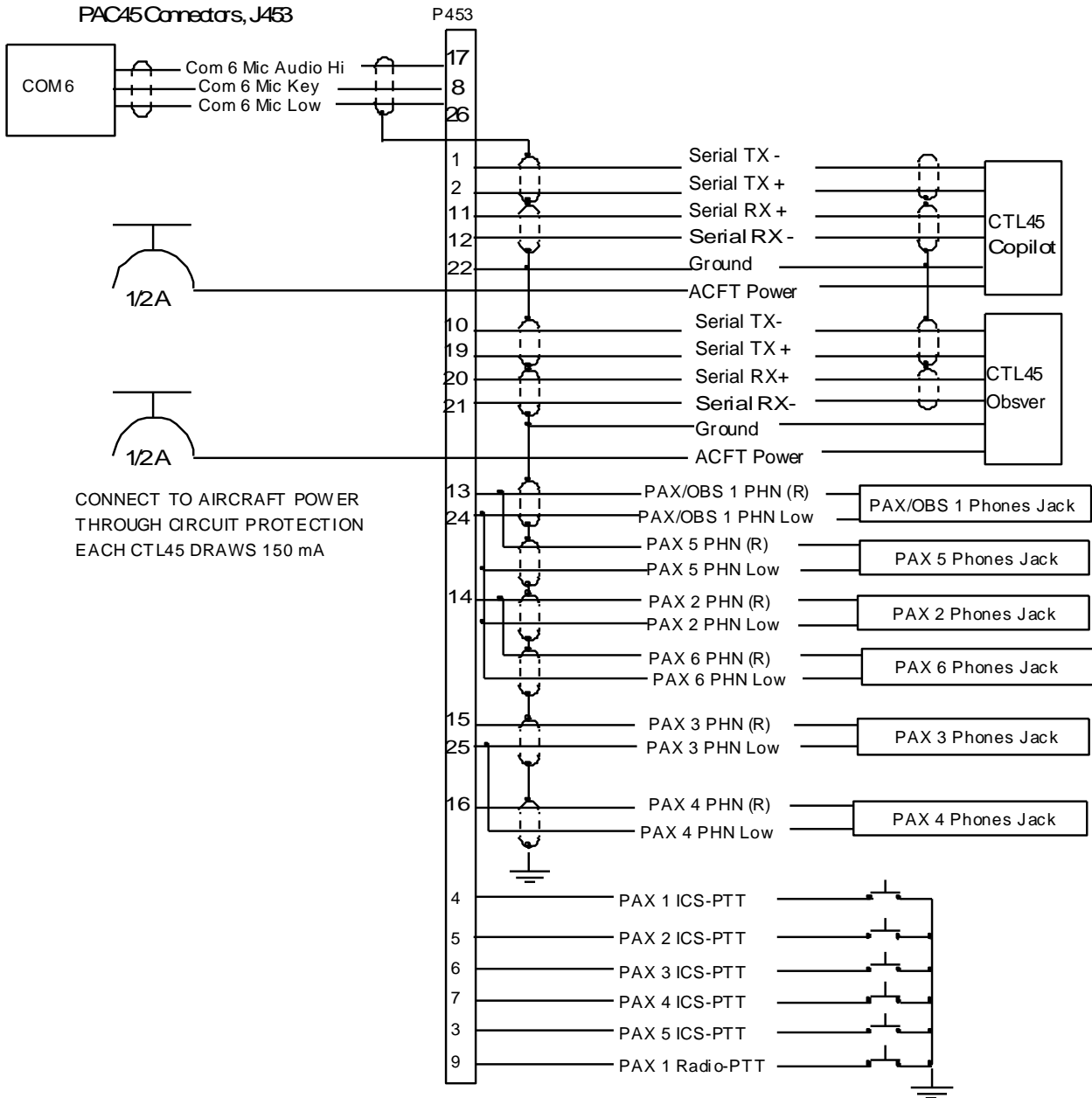




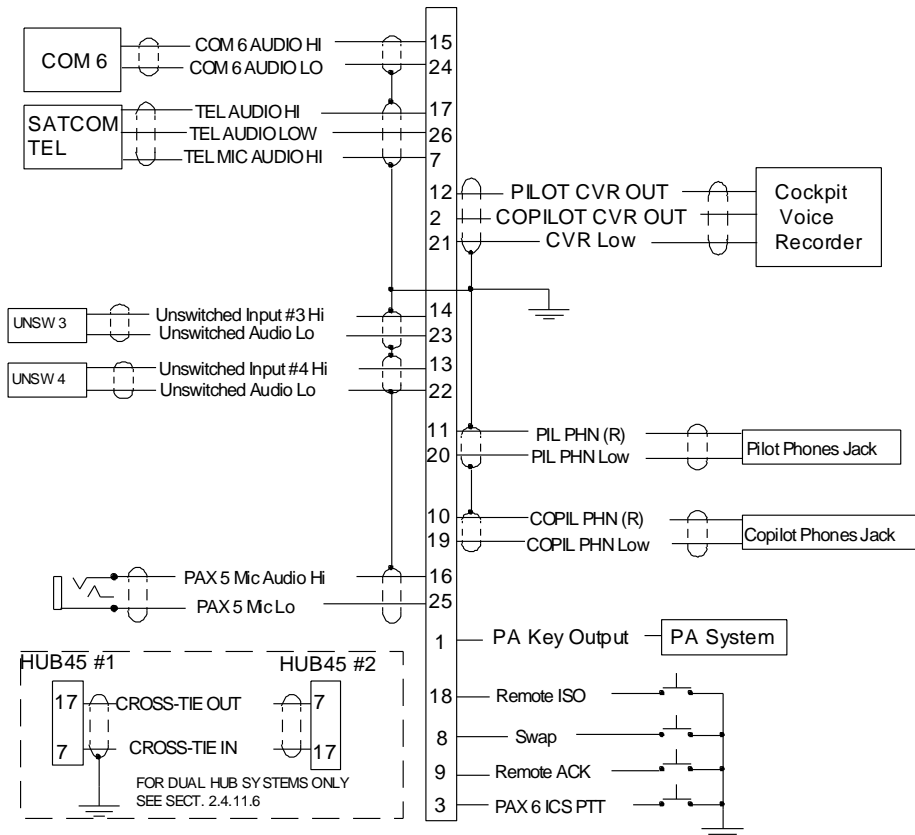
## 9.2 J452 Connections



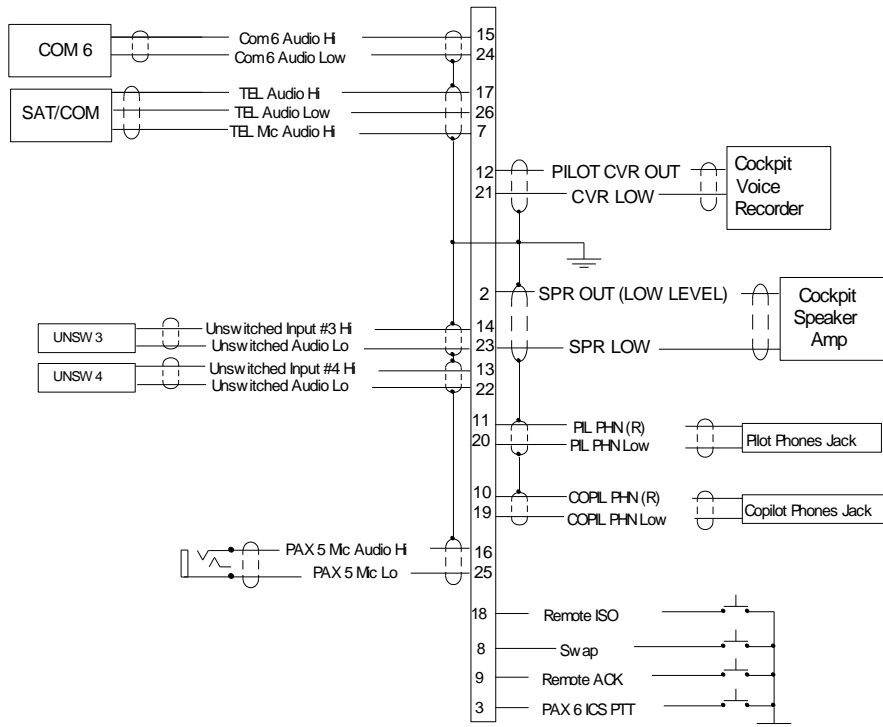
### 9.3 J453 Connections



### 9.4 J454 Connections



J454 Connections with Single CVR and Speaker Output (050-045-0002 and 050-045-0102)



## Appendix F – Instructions for FAA Form 337 and continuing airworthiness

### 10.1 Instructions for FAA Form 337, Audio controllers

One method of airworthiness approval is through an FAA Form 337, *Major Repair and Alteration (Airframe, Powerplant, Propeller, or Appliance)* In the case of the PAC45, you may use the following text as a guide.

Installed audio selector and 6-place intercom, PS Engineering PAC45, part number 050-045-(XXXX) in ( location ) at station \_\_\_\_ Installed per AC43.13-2, Chapter 2, paragraph 23 (Instrument Panel Mounting). Installed per PS Engineering *Installation Operators Manual* p/n 200-045-(XXXX), revision ( ), dated ( ).

These units are FAA-Approved under TSO C139A for audio amplifiers, and meets environmental qualifications outlined in RTCA DO-160G as appropriate or this aircraft.

Interface to existing aircraft radios in accordance with installation manual and in compliance with practices listed in AC43.13-2, Chapter 2. All wires are Mil-Spec 22759 or 27500. Connection to aircraft dimmer bus is \_\_\_\_\_.

Power is supplied to the unit through a #A circuit breaker (type and part number), and total electrical load does not exceed \_\_\_\_% of the electrical system capacity with the PAC45 added.

Aircraft equipment list, weights and balance amended. Compass compensation checked. A copy of the operation instructions, contained in PS Engineering document 202-045-( ), revision ( ), dated ( ), is placed in the aircraft records. All work accomplished listed on Work Order \_\_\_\_\_.

### 10.2 Instructions for Continuing Airworthiness, Audio System

Sample ICA Checklist for PS Engineering PAC45 Audio System:

| Section | Item                                | Information   |
|---------|-------------------------------------|---|
| 1       | Introduction                        | Installation of audio control panel with intercommunications system, with integrated audio alert system.  |
| 2       | Description                         | Installation as described in manufacturer's installation manual referenced on installation documentation (FAA Form 337, etc.), including interface with other avionics audio as required.   |
| 3       | Controls                            | See installation and operator's guide referenced on installation documentation.   |
| 4       | Servicing                           | None Required   |
| 5       | Maintenance Instructions            | On Condition, no special instructions   |
| 6       | Troubleshooting                     | In the event of a unit problem, place the unit into "off," "fail-safe" and/or "emergency" mode. This allows pilot communications using COM 1, and unswitched audio for critical alerts, copilot communications on COM 2, pilot navigation audio 1 if stereo headsets are used,. Follow checkout instructions in the installation manual referenced on the FAA Form 337. For a specific unit fault, contact the manufacturer at (865) 988-9800 for special instructions.   |
| 7       | Removal and replacement information | <u>Removal:</u> The PAC45/CTL45 is attached to the aircraft using ¼-turn Dzus fasteners. To release, insert a slotted screwdriver into the head and turn counter-clockwise. Release the wiring connectors by sliding the latches from the retaining standoff.<br><br>The HUB45R is attached to the aircraft using four #6 screws on the flanges.<br><u>Installation:</u> Reverse the connector installation process. Place the unit against the Dzus rail and with the slotted screwdriver push gently and turn ¼-turn to secure. |
| 8       | Diagrams                            | Not applicable  |
| 9       | Special Inspection Requirements     | Not Applicable  |
| 10      | Protective Treatments               | Not Applicable  |
| 11      | Structural Data                     | Not Applicable  |
| 12      | Special Tools                       | None  |
| 13      | Not Applicable                      | Not Applicable  |
| 14      | Recommended Overhaul Periods        | None  |
| 15      | Airworthiness Limitations           | Not Applicable  |
| 16      | Revision                            | To be determined by installer   |

## Appendix G – RTCA DO160G Environmental Qualification Form

### 11.1 Model Number PAC45 Audio Selector Panel/Intercom Remote Hub

Part Number: 050-045-( )

FAA TSO Number: C139a,

Manufacturer: PS Engineering Incorporated      9800 Martel Road      Lenoir City TN 37772

| Conditions                                 | Section | Conducted Tests  |
|--|---------|--|
| Temperature and Altitude                   | 4.0     | Equipment tested to CAT D2   |
| Low Temperature                            | 4.5.1   | -45°C Low Operating  |
|  | 4.5.2   | -55° C Survival,   |
|  | 4.5.4   | -45°C Low Short-Term Operating   |
| High Temperature                           | 4.6.1   | +85°C Survival,  |
|  | 4.6.2   | +70°C High Operating   |
|  | 4.6.3   | +70°C High Short Time Operating  |
| In-flight Loss of Cooling                  |         | Not Applicable, no cooling required  |
| Altitude                                   |         | 50,000' unpressurized (D2)   |
| Decompression                              |         | Not Applicable   |
| Overpressure                               |         | Not Applicable   |
| Temperature variation                      | 5.2     | Equipment tested to Category B   |
| Humidity                                   | 6.0     | Equipment tested to Category A   |
| Shock                                      | 7.0     | Equipment tested to Category B Standard operational shock and crash safety |
| Vibration                                  | 8.0     | Equipment tested to Category SM, SB, U2FF1, Helicopter Random              |
| Explosion                                  | 9.0     | Category X, not tested   |
| Waterproofness                             | 10.0    | Category X, not tested   |
| Fluids Susceptibility                      | 11.0    | Category X, not tested   |
| Sand and Dust                              | 12.0    | Category X, not tested   |
| Fungus                                     | 13.0    | Category X, not tested   |
| Salt Spray                                 | 14.0    | Category X, not tested   |
| Magnetic Effect                            | 15.0    | Equipment tested to Category Z   |
| Power input                                | 16.0    | Equipment tested to Category Z (28V)                                       |
| Voltage Spike                              | 17.0    | Equipment tested to Category A (600V)                                      |
| Audio Frequency Susceptibility             | 18.0    | Equipment tested to Category Z   |
| Induced Frequency Susceptibility           | 19.0    | Equipment tested to Category ZC  |
| Radio Frequency Susceptibility             | 20.0    | Equipment tested to Category T   |
| Radio Frequency Emission                   | 21.0    | Equipment tested to Category B   |
| Lightning Induced Transient Susceptibility | 22.0    | Equipment tested to Category A3J33   |
| Lightning Direct Effects                   | 23.0    | Category X, not tested   |
| Icing                                      | 24.0    | Category X, not tested   |
| ESD  | 25.0    | Category A   |

## 11.2 Model Number CTL45, Audio Selector Control Panel

Part Number: 050-045-(02XX, -03XX, -62XX, -63XX )

FAA TSO Number: C139a

Manufacturer: PS Engineering Incorporated      9800 Martel Road      Lenoir City TN 37772

| Conditions                                 | Section | Conducted Tests  |
|--|---------|--|
| Temperature and Altitude                   | 4.0     | Equipment tested to CAT D2   |
| Low Temperature                            | 4.5.1   | -45°C Low Operating  |
|  | 4.5.2   | -55° C Survival,   |
|  | 4.5.4   | -45°C Low Short Time Operating   |
| High Temperature                           | 4.6.1   | +85°C Survival,  |
|  | 4.6.2   | +70°C High Operating   |
|  | 4.6.3   | +70°C High Short Time Operating  |
| In-flight Loss of Cooling                  |         |  |
| Altitude                                   |         | Not Applicable, no cooling required  |
| Decompression                              |         | 50,000' unpressurized (D2)   |
| Overpressure                               |         | Not Applicable   |
|  |         | Not Applicable   |
| Temperature variation                      | 5.2     | Equipment tested to Category B   |
| Humidity                                   | 6.0     | Equipment tested to Category B (Severe)                                    |
| Shock                                      | 7.0     | Equipment tested to Category B Standard operational shock and crash safety |
| Vibration                                  | 8.0     | Equipment tested to SM, SB, U2FF1, Helicopter Random                       |
| Explosion                                  | 9.0     | Category X, not tested   |
| Waterproofness                             | 10.0    | Category X, not tested   |
| Fluids Susceptibility                      | 11.0    | Category X, not tested   |
| Sand and Dust                              | 12.0    | Category X, not tested   |
| Fungus                                     | 13.0    | Category X, not tested   |
| Salt Spray                                 | 14.0    | Category X, not tested   |
| Magnetic Effect                            | 15.0    | Equipment tested to Category Z   |
| Power input                                | 16.0    | Equipment tested to Category Z (28V)                                       |
| Voltage Spike                              | 17.0    | Equipment tested to Category A (600V)                                      |
| Audio Frequency Susceptibility             | 18.0    | Equipment tested to Category Z   |
| Induced Frequency Susceptibility           | 19.0    | Equipment tested to Category ZC  |
| Radio Frequency Susceptibility             | 20.0    | Equipment tested to Category T   |
| Radio Frequency Emission                   | 21.0    | Equipment tested to Category B   |
| Lightning Induced Transient Susceptibility | 22.0    | Equipment tested to Category A3J33   |
| Lightning Direct Effects                   | 23.0    | Category X, not tested   |
| Icing                                      | 24.0    | Category X, not tested   |
| ESD  | 25.0    | Category A   |