

PAC24 Configuration Quick Reference Guide

HYPERLINKED QUICK REFERENCE:

If you have:	Use Section	If you have:	Use Section
Single PAC24	§2.1	Single PAC24 with expansion	§2.2
Dual PAC24	§2.3	Dual PAC24 with expansion	§2.4
Observer PAC24	§5.1	Observer PAC24 with expansion	§5.2
Single PAC24 Vertical	§2.1	Single PAC24 Vertical with expansion	§2.2
Dual PAC24 Vertical	§2.3	Dual PAC24 Vertical with expansion	§2.4

[This document is intended to augment the PAC24 Installation Manual, Document 200-240-0010](#)

Table of Contents

1.0	Introduction	3
1.1	Applicability	3
1.2	Detail unit description	4
2.0	PAC24 Standard (050-240-0100) DIP switch Configurations	4
2.1	Single PAC24	4
2.2	Single PAC24 with Expansion	5
2.3	Dual PAC24	7
2.3.1	Dual PAC24 installation, Pilot’s Audio Panel.....	7
2.3.2	Dual PAC24 installation, Copilot’s Audio Panel	9
2.4	Dual PAC24 Installation, with Expansion	9
2.4.1	Dual PAC24 with Expansion, Pilot’s panel	10
2.4.2	Dual Installation, Copilot’s audio panel.....	11
3.0	Circuit jumper positions.....	12
3.1	Single Panel or Pilot’s Panel Jumper Configuration	12
3.2	Dual PAC24 Copilot’s or Observer’s Panel Jumper Configuration.....	13
4.0	Other Switch settings.....	13
4.1	Switch 4.....	13
4.2	S5 Position 4, TEL.....	14
5.0	PAC24 Observer versions (050-240-0400)	14
5.1	Dual PAC24 Observer, with 1 passenger (no expansion).....	15
5.1.1	PAC24 Observer version, Crew’s audio panel.....	16
5.1.2	PAC24 Observer version, Observer’s audio panel	17
5.2	PAC24 Observer Installation with Expansion	18
5.2.1	PAC24 Observer version with Expansion, Crew’s audio panel.....	19
5.2.2	PAC24 Observer version (-0400), Observer’s panel	20
6.0	DIP Switch Cross reference.....	21
6.1	DIP Switch tables by configuration.....	22

Table of Figures & Tables

Figure 1	System Diagram, Single PAC24.....	5
Table 1	Switch Settings, Single PAC24 (Default from factory).....	5
Figure 2	Switch Positions, PAC24 Single Unit Standard	5
Table 2	Switch Settings, Single PAC24 with expansion.....	6
Figure 3	Switch Positions, PAC24 Single Panel with expansion	6
Table 3	Switch settings, Dual installation, Pilot's audio panel (050-240-0100).....	8
Figure 4	Switch positions, Dual PAC24 (-0100), Pilot Side Audio Panel	8
Table 4	Switch settings, Dual PAC24, Copilot's audio panel.....	9
Figure 5	Switch positions, Dual PAC24 Copilot's audio panel	9
Figure 6	Diagram of Dual PAC24 with expansion.....	10
Table 5	Switch settings, Dual PAC24 with expansion, pilot's audio panel.....	10
Figure 7	Switch positions, Dual PAC24 with expansion, plot's audio panel (-0100)	11
Table 6	Switch settings, Dual PAC24 with expansion, Copilot's audio panel.....	11
Figure 8	Switch positions, Dual PAC24 with expansion, Copilot's panel.....	12
Table 7	Pilot/Single PAC24 Jumper configuration	12
Figure 9	Jumpers J4 and J5 positions	13

Table 8 Copilot’s or Observer’s panel PAC24 Jumper configuration 13
 Figure 10 Jumpers J4 and J5 positions 13
 Table 9 S4 Switch functions 14
 Figure 11 S4 Switch positions 14-Volt 28-volt 14
 Table 10 SW5 COM 5 Duplex Enable 14
 Figure 12 S5 Switch positions COM 5 Duplex TEL mode..... 14
 Figure 13 System diagram Dual PAC24 Observer without expansion. 15
 Table 11 Switch Settings, Dual PAC24 Observer, Crew’s panel 16
 Figure 14 Switch positions, Dual PAC24 Observer, Crew’s panel 16
 Table 12 Switch Settings, Dual PAC24 Observer, Observer’s panel 17
 Figure 15 Switch positions, Dual PAC24 Observer, Observer’s panel..... 17
 Figure 16 Diagram of PAC24 Observer configuration with 6-place expansion 18
 Table 13 Switch Settings, Dual PAC24 Observer with expansion, Crew’s panel 19
 Figure 17 Switch positions, Dual PAC24 Observer with expansion, Crew’s panel 19
 Table 14 Switch Settings, Dual PAC24 Observer with expansion, Observer’s panel 20
 Figure 18 Switch positions, Dual PAC24 Observer with expansion, Observer’s panel..... 20
 Figure 19 DIP Switch Schematic representation 21
 Table 6-1 Single Audio Panel DIP switch settings 22
 Table 6-2 Dual Audio Panel DIP Switch Settings without expansion 22
 Table 6-3 Dual Audio Panel DIP Switch Settings with expansion 22
 Table 6-4 Dual Audio Panel with Observer Function, DIP switch settings 22
 Table 6-5 Dual Audio Panel with observer and with Expansion 23

1.0 Introduction

This document describes the internal configuration settings for the different applications of the PAC24 Audio Control Panel. Switch settings are described in several different ways, text, table and graphically. So if it seems redundant or complicated, don’t worry. Just pick the representation that works best for you.

In pictures where the switches are grayed out, these switch settings are not relevant to the settings being described, but will be detailed in a different location.

To further help avoid confusion, the specific audio panel settings for the second audio panel in dual systems are color coded, **Copilot** audio panel and **Observer’s** audio panel.

1.1 Applicability

This document applies to PAC24-series units:

Model	Description	Part Number
PAC24	Standard	050-240-0100
PAC24	Observer	050-240-0400
PAC24	Vertical	050-240-0500

1.2 Detail unit description

PAC24 Standard (050-240-0100) is applicable to single or dual installations. It will directly replace a King KMA24H -71.

Note: Some installations may have a privacy/isolate switch or switches installed. These may have to be removed and/or bypassed. See complete installation manual for details.

The PAC24 Observer version (050-240-0400) is a special model that will accommodate three crew members transmitting, using two audio panels. One audio panel is for the crew (pilot and copilot) and the Observer's audio panel services that position, and dedicated communications radios. **This version is ALWAYS installed as a dual system, and the two units *always* have identical part numbers.**

The PAC24 is available in Vertical Orientation (050-240-0500). These units are configured in the same manner as the -0100 units.

The PAC24 (050-240-0503) was also sold into special mission versions, which are beyond the scope of this document. Contact the factory if details are needed.

2.0 PAC24 Standard (050-240-0100) DIP switch Configurations

To change the DIP (Dual Inline Package) switch, remove the TOP cover of the PAC24 by removing the two screws at the sides. The switches will be visible at the rear of the unit. Use a small screwdriver or pencil to slide the switch "On" or "Off." Be careful not to break the switch.

2.1 Single PAC24

As originally shipped from PS Engineering, the units are configured as Single Panel installation, 28-volt aircraft, without expansion. This is suitable for a single panel, pilot and copilot operation, with up to three passengers. The passenger headphone audio is paralleled with the copilot, so a true "crew" mode is not possible.

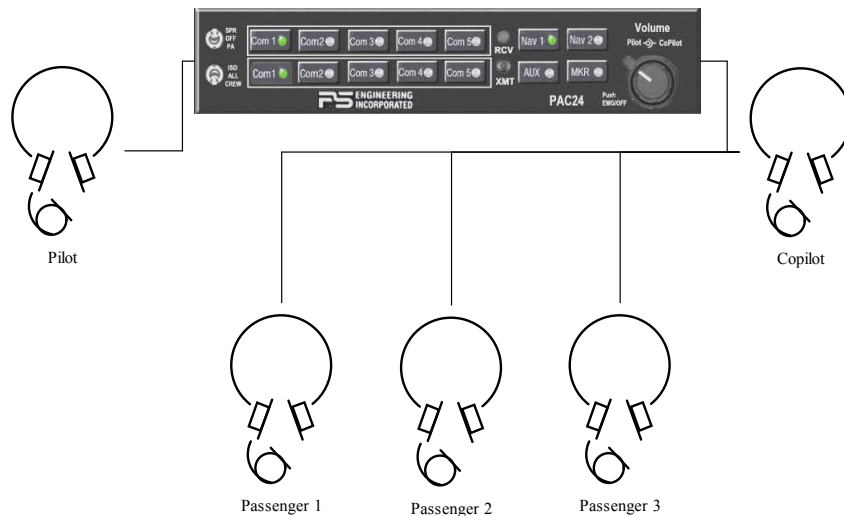

Figure 1 System Diagram, Single PAC24

Function	Switch	Setting	Function	Switch	Setting
S2			S3		
CVR Audio	1	On	Pass 1 Mic	1	On
Playback	2	Off	Expansion In	2	Off
Pass 3 Mic	3	On	Pass 2 Mic	3	On
Expansion Power	4	Off	Expansion Out	4	Off
S4			S5		
14 V lights	1	Off	Expansion Active	1	Off
Swap	2	On	Dual System	2	Off
28V lights	3	On	Copilot Unit	3	Off
Swap	4	Off	TEL Duplex	4	Off

Table 1 Switch Settings, Single PAC24 (Default from factory)

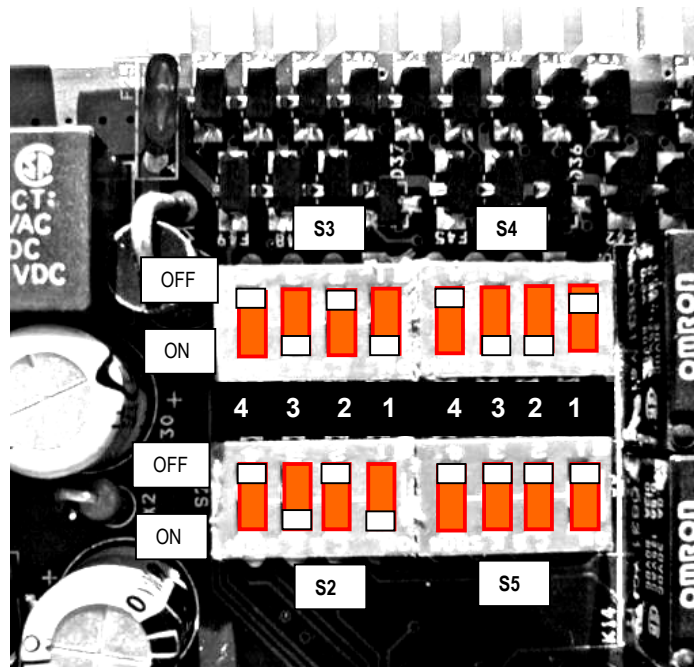

Figure 2 Switch Positions, PAC24 Single Unit Standard

NOTE: Circuit Jumpers J4 and J5 MUST be configured as described in § 3.1

2.2 Single PAC24 with Expansion

The PAC24 (-0100) can be expanded. This will add up to 6 places for passenger intercom, and a stereo music input for them. It will also give the system a true “crew” mode, where the pilot and copilot positions will not hear the passengers, the passengers will not hear the crew, or the aircraft radios in the CREW mode.

PS Engineering
PAC24 Series Audio Selector Panel and Intercom System
Configuration Setup Guide

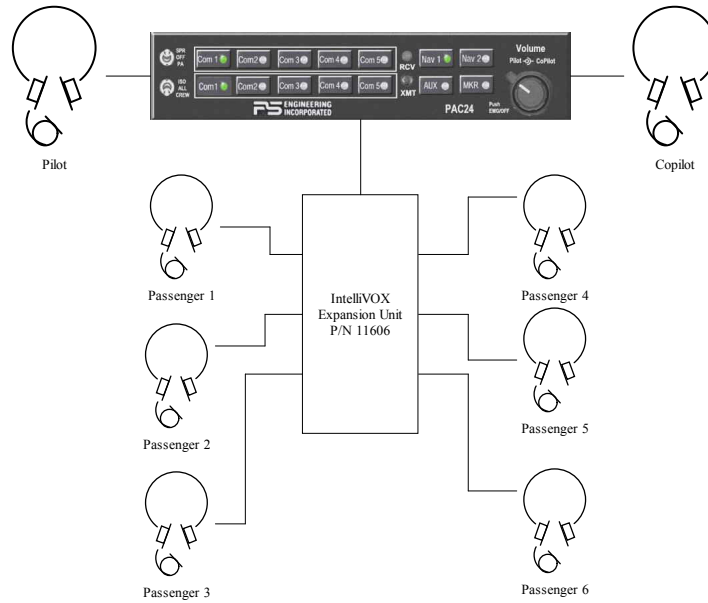

This configuration requires that S2, S3 and S5 to be changed.

S2		S3	
Switch 3	Off	Switch 1	Off
Switch 4	On	Switch 2	On
S5		Switch 3	Off
Switch 1	On	Switch 4	On

Table 2 Switch Settings, Single PAC24 with expansion

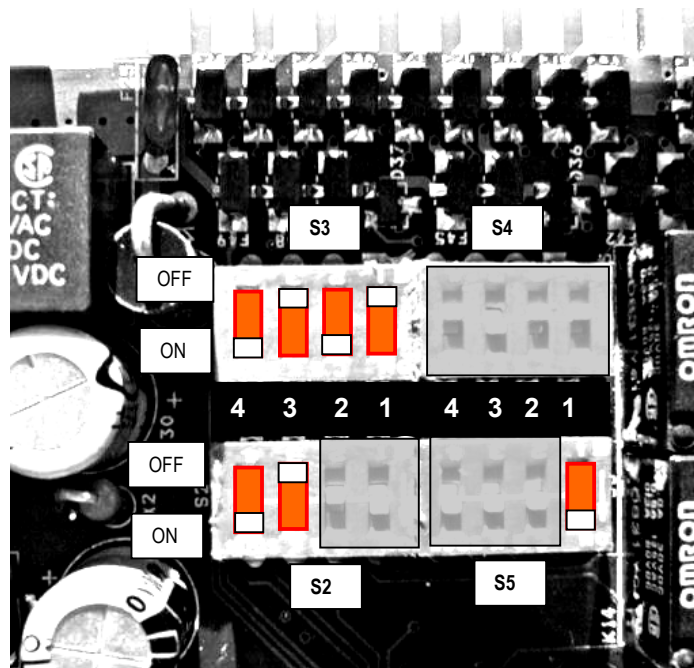

Figure 3 Switch Positions, PAC24 Single Panel with expansion

Refer to Section [4.0](#) for settings of S4 and S5, Switch 4.

NOTE: Circuit Jumpers J4 and J5 MUST be configured as described in § 3.1

2.3 Dual PAC24

Two PAC24s can be combined to give full audio control to both pilot and copilot positions. Function logic is shared between units to prevent any unusable states from occurring, such as two pilots transmitting on the same radio. The audio panel that is designated as Pilot’s will have priority in transmitting, and that audio panel intercom mode selector (ISO/ALL/Crew) will be functional.

Up to three passengers can be connected to each audio panel, and these positions will hear the other panel’s passengers. Note: Passengers headphones are shared with the copilots so CREW function will not work unless expansion 11606 is installed.

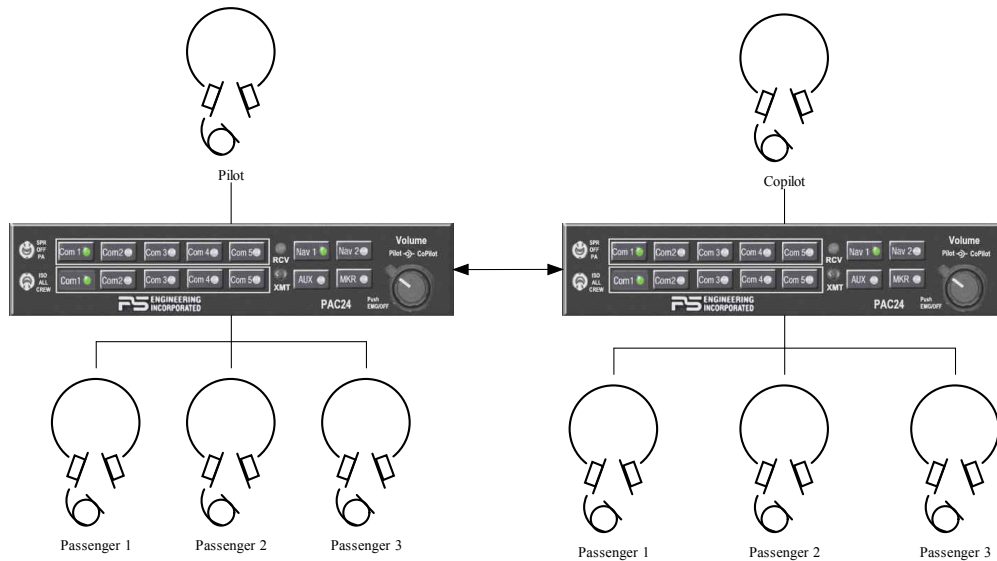

2.3.1 Dual PAC24 installation, Pilot’s Audio Panel

S5		
Switch 2	Dual System	On
Switch 3	Copilot Panel	Off

Table 3 Switch settings, Dual installation, Pilot's audio panel (050-240-0100)

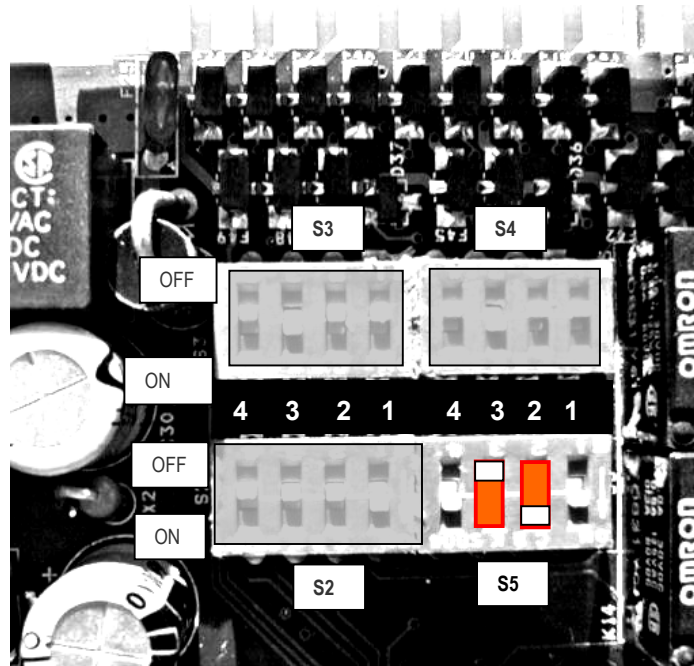

Figure 4 Switch positions, Dual PAC24 (-0100), Pilot Side Audio Panel.

[NOTE: Circuit Jumpers J4 and J5 MUST be configured as described in § 3.1](#)

Dual PAC24 installation, Copilot's Audio Panel

S5		
Switch 2	Dual System	On
Switch 3	Copilot Panel	On

Table 4 Switch settings, Dual PAC24, **Copilot's** audio panel

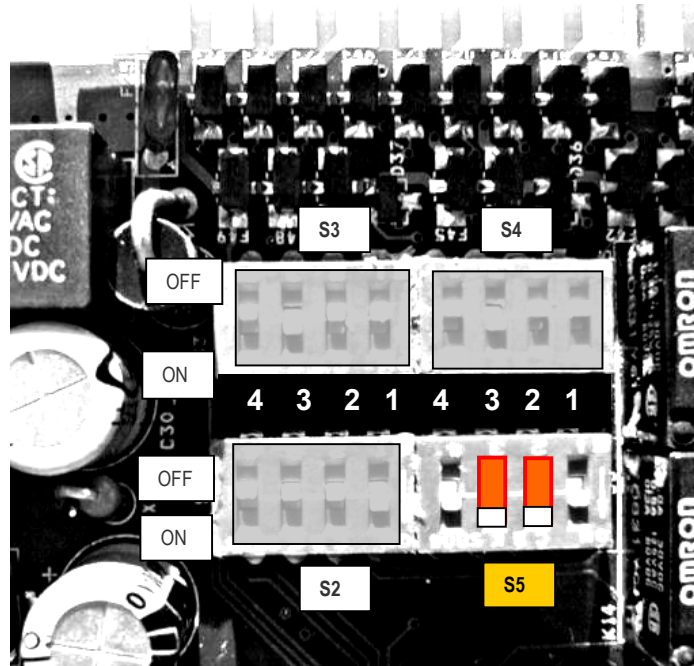

Figure 5 Switch positions, Dual PAC24 **Copilot's** audio panel

NOTE: Circuit Jumpers J4 and J5 MUST be configured as described in § 3.2

2.4 Dual PAC24 Installation, with Expansion

Two PAC24s can be combined with IntelliVox™ expansion units. This provides up to 12 passengers and 2 crew positions. This configuration provides a true “crew” mode, where the passengers can be isolated from the crew and will not hear aircraft radios.

This configuration requires that S2, S3 and S5 be changed.

PS Engineering
PAC24 Series Audio Selector Panel and Intercom System
Configuration Setup Guide

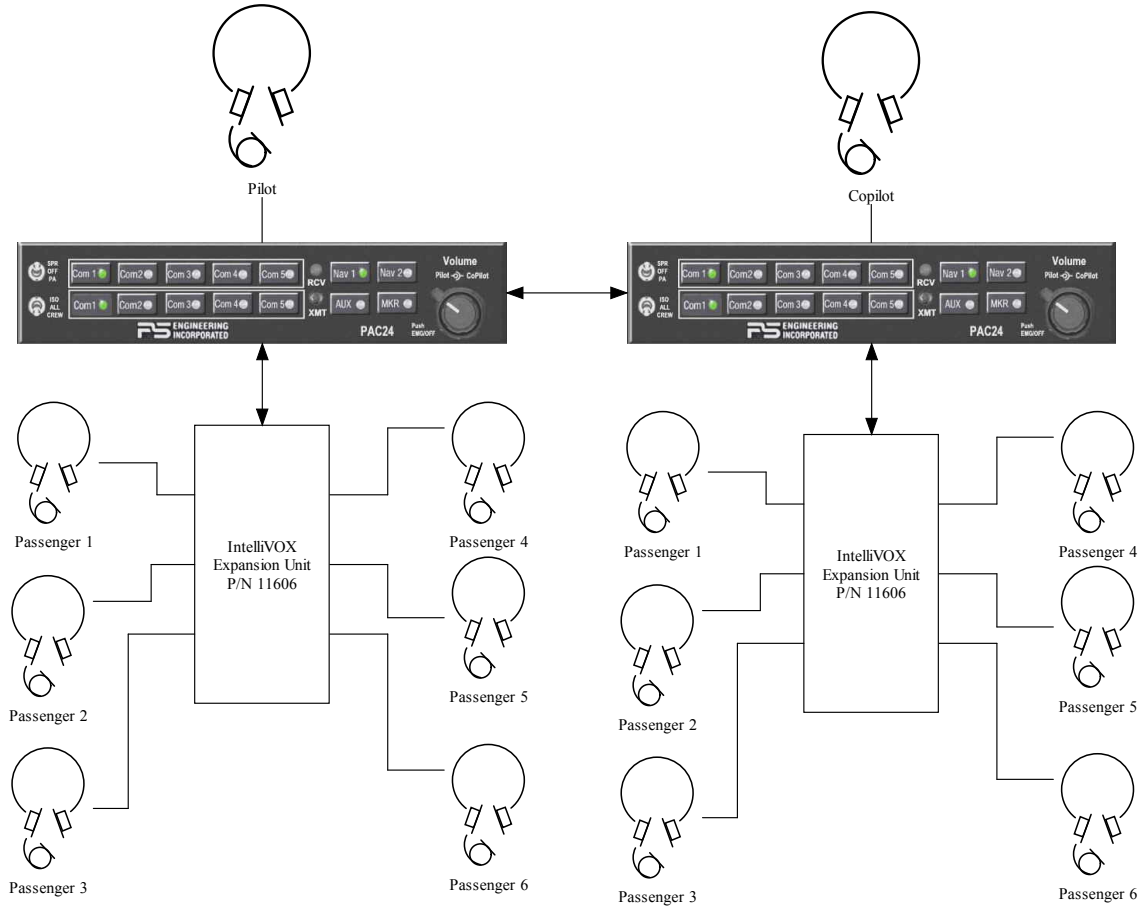

Figure 6 Diagram of Dual PAC24 with expansion

2.4.1 Dual PAC24 with Expansion, Pilot's panel

S2		S3	
Switch 3	Off	Switch 1	Off
Switch 4	On	Switch 2	On
S5		Switch 3	Off
Switch 1	On	Switch 4	On
Switch 2	On		
Switch 3	Off		

Table 5 Switch settings, Dual PAC24 with expansion, pilot's audio panel

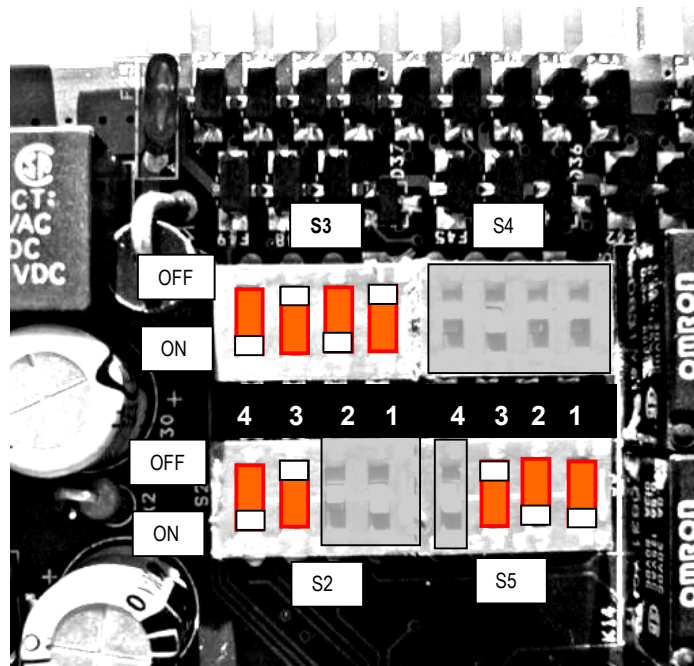

Figure 7 Switch positions, Dual PAC24 with expansion, pilot's audio panel (-0100)

NOTE: Circuit Jumpers J4 and J5 MUST be configured as described in § 3.1

2.4.2 Dual Installation, Copilot's audio panel

The copilot's audio panel does not have transmit priority, and the ICS mode switch is inactive.

S2		S3	
Switch 3	Off	Switch 1	Off
Switch 4	On	Switch 2	On
S5		Switch 3	Off
Switch 1	On	Switch 4	On
Switch 2	On		
Switch 3	On		

Table 6 Switch settings, Dual PAC24 with expansion, Copilot's audio panel

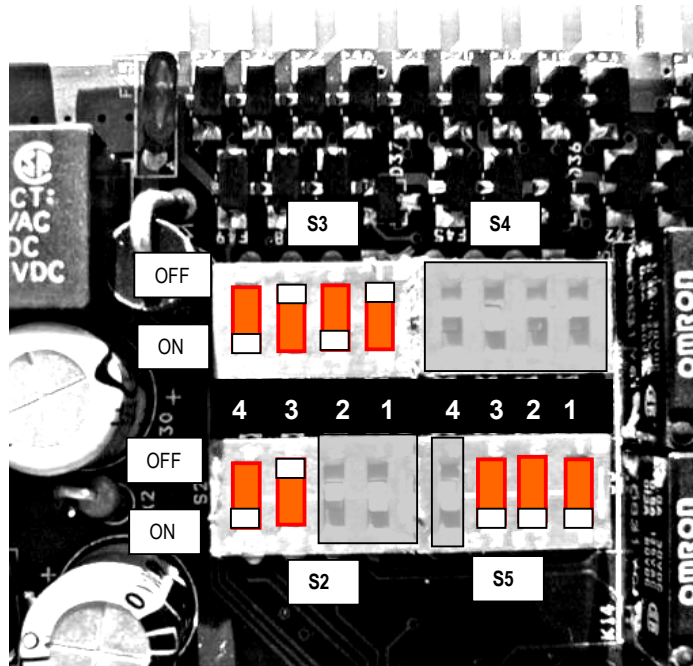

Figure 8 Switch positions, Dual PAC24 with expansion, [Copilot's panel](#)

[NOTE: Circuit Jumpers J4 and J5 MUST be configured as described in § 3.2](#)

3.0 Circuit jumper positions

Two circuit jumpers are used to control the microphone audio and radio P-T-T path for fail safe configuration. These jumpers are located at the rear corner of the PAC24. Remove the top cover as described in [§ 2.0](#).

3.1 Single Panel or Pilot's Panel Jumper Configuration

This is the jumper configuration used in a single panel installation, or the pilot audio panel in a dual installation.

Pilot Panel or Single Installation		
Failsafe radio P-T-T Jumper	J4	On
Failsafe Mic Audio Jumper	J5	Pins 1 & 2

Table 7 Pilot/Single PAC24 Jumper configuration

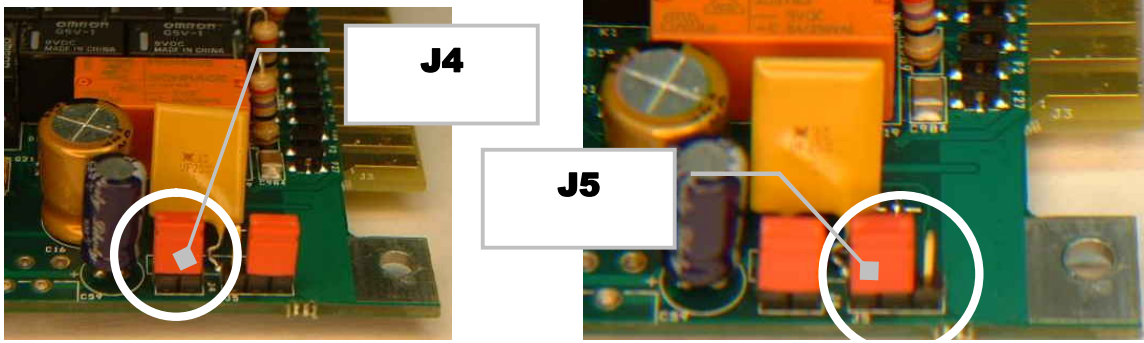

J4 jumper for single or Pilot's audio panel J5 jumper for single or Pilot's audio panel

Figure 9 Jumpers J4 and J5 positions

3.2 Dual PAC24 Copilot's or Observer's Panel Jumper Configuration

This is the jumper configuration used for the copilot's or observer's audio panel in a dual panel installation.

Copilot or Observer Panel Dual Installation		
Failsafe radio P-T-T Jumper	J4	Off
Failsafe Mic Audio Jumper	J5	Pins 2 & 3

Table 8 Copilot's or Observer's panel PAC24 Jumper configuration

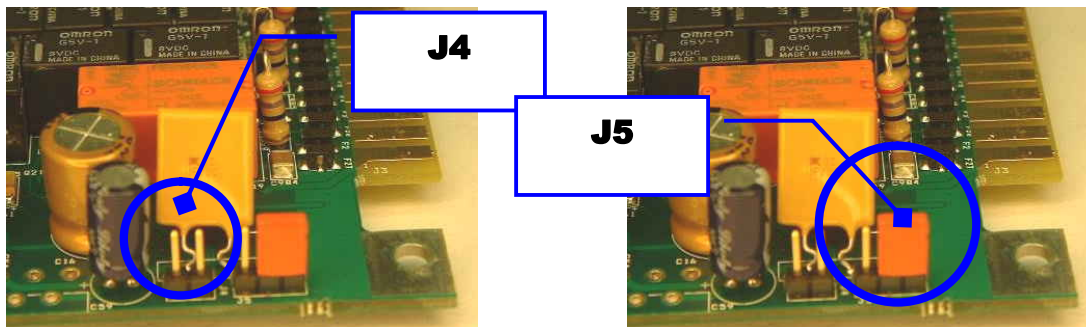

J4 jumper for copilot /observer's panel J5 jumper for copilot /observer's panel

Figure 10 Jumpers J4 and J5 positions

4.0 Other Switch settings

4.1 Switch 4

The PAC24 has PS Engineering's patented "swap" mode that allows the pilot to switch the com radio selected for transmit by pushing an optional momentary switch located on the yoke, panel or cyclic as convenient. This allows changing the radio without having to let go of the controls and reach the audio panel.

This "swap input is shared with the lighting bus, such that in a 28-volt aircraft, the lighting bus is input on pin U, and swap is implemented by grounding pin 18. In a 14-volt

aircraft, the pin assignments are reversed, and S4 is changed to accommodate this configuration.

S4	Function	14-Volt	28-Volt
1	14V Light	On	Off
2	Swap	Off	On
3	28V Light	Off	On
4	Swap	On	Off

Table 9 S4 Switch functions

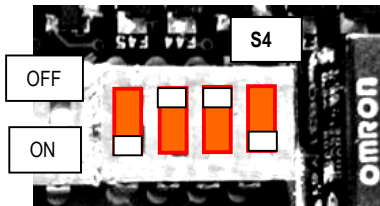

14-Volt lighting

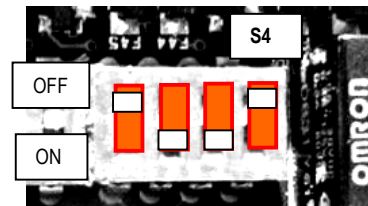

28-Volt lighting

Figure 11 S4 Switch positions 14-Volt 28-volt

4.2 S5 Position 4, TEL

The PAC24 can be used to interface a cellular or satellite telephone into the aircraft audio system, as COM 5. In this case, S5, position 4 must be in the “ON” position to allow a full duplex operation on COM 5.

S5	VHF COM	Cellular or Satellite phone
4	Off	On

Table 10 SW5 COM 5 Duplex Enable

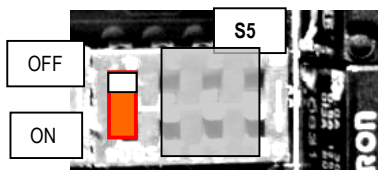

COM 5 VHF/HF

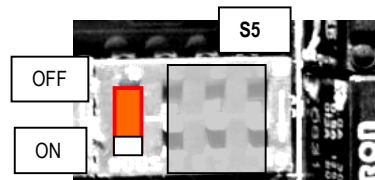

COM 5 Duplex TEL

Figure 12 S5 Switch positions COM 5 Duplex TEL mode

5.0 PAC24 Observer versions (050-240-0400)

This configuration allows three transmit positions, with the observer access to the communications transceivers connected to the audio panel designated as observer. These can be, but are not necessarily the ones used by the crew, or a combination thereof. The Observer version is a **special part number** of the PAC24 (-0400).

This is *always* a dual installation, and both part numbers *must* be the same (-0400).

The DIP switches are set at the factory, and the audio panels are individually labeled “Crew” and “Observer.” The settings are provided here for reference.

5.1 Dual PAC24 Observer, with 1 passenger (no expansion).

In this configuration, the observer unit can support one additional passenger on the intercom, for a total of four persons on the aircraft audio system. This configuration can only support one passenger besides the crew and observer because the microphone inputs are used for the observer panel interface.

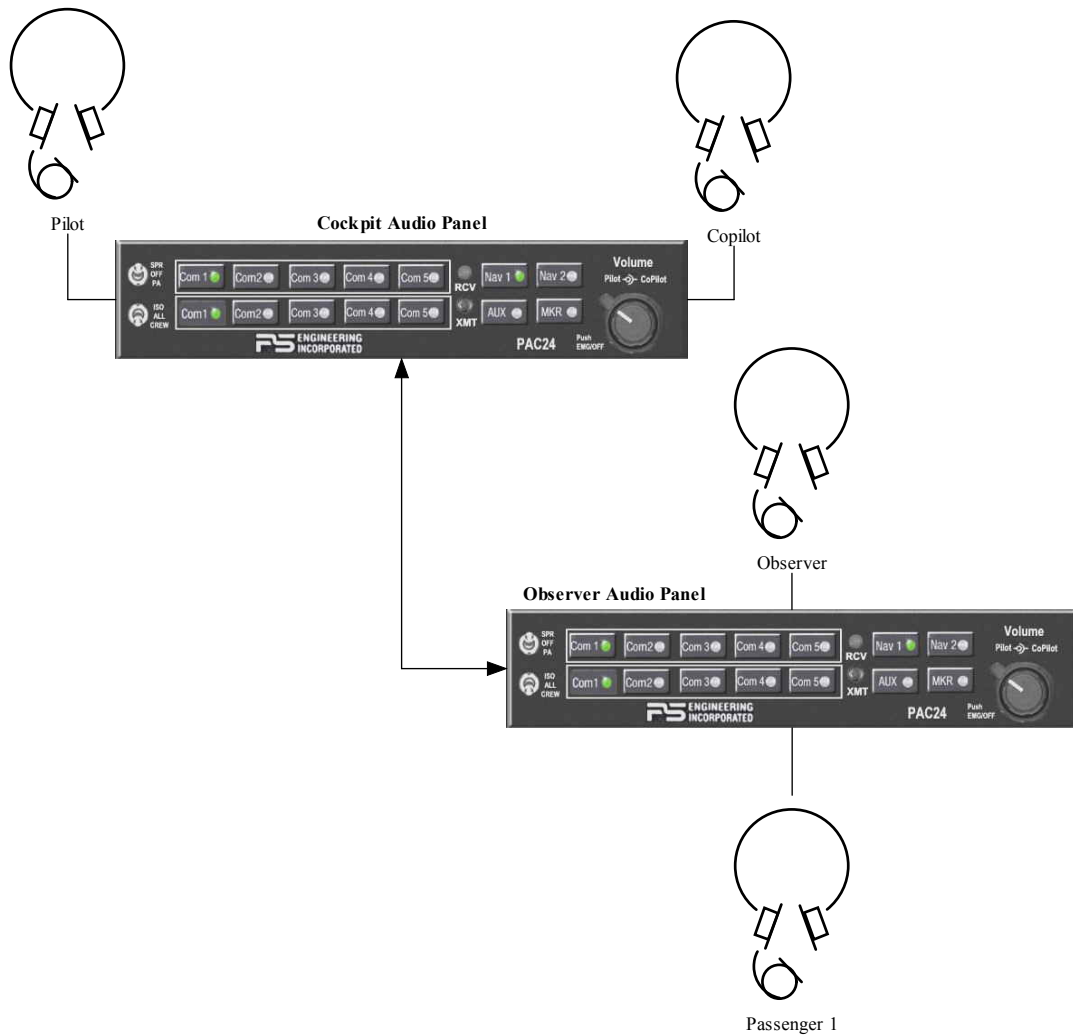

Figure 13 System diagram Dual PAC24 Observer without expansion.

5.1.1 PAC24 Observer version, Crew's audio panel

S2		S3	
Switch 1	On	Switch 1	Off
Switch 2	Off	Switch 2	On
Switch 3	On	Switch 3	Off
Switch 4	Off	Switch 4	On
S5			
Switch 1	Off		
Switch 2	On		
Switch 3	Off		

Table 11 Switch Settings, Dual PAC24 Observer, Crew's panel

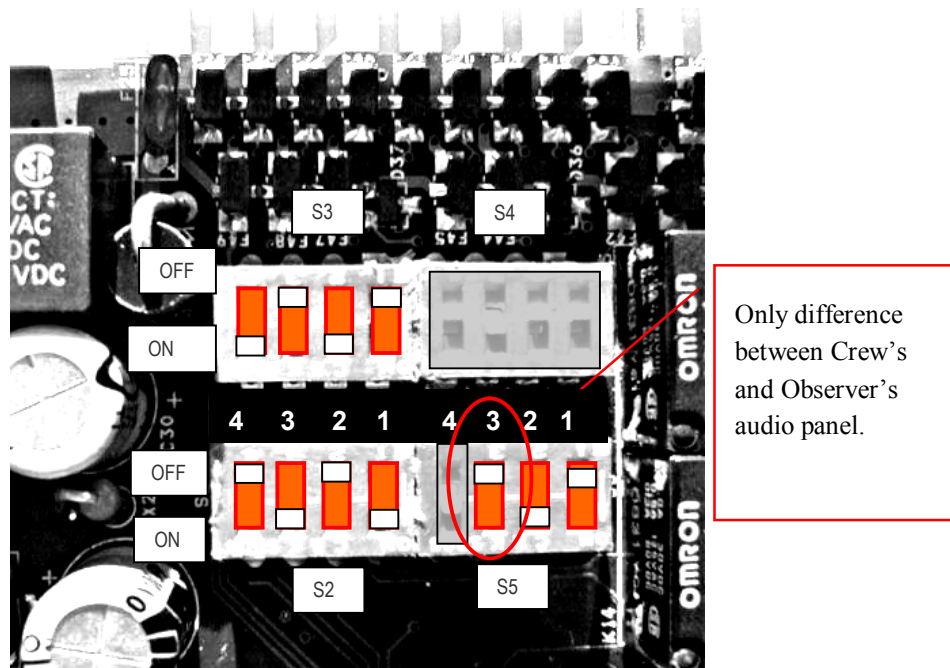

Figure 14 Switch positions, Dual PAC24 Observer, Crew's panel

Refer to Section [4.0](#) for settings of S4 and S5, Switch 4.

5.1.2 PAC24 Observer version, Observer's audio panel

S2		S3	
Switch 1	On	Switch 1	Off
Switch 2	Off	Switch 2	On
Switch 3	On	Switch 3	Off
Switch 4	Off	Switch 4	On
S5			
Switch 1	Off		
Switch 2	On		
Switch 3	On		

Table 12 Switch Settings, Dual PAC24 Observer, Observer's panel

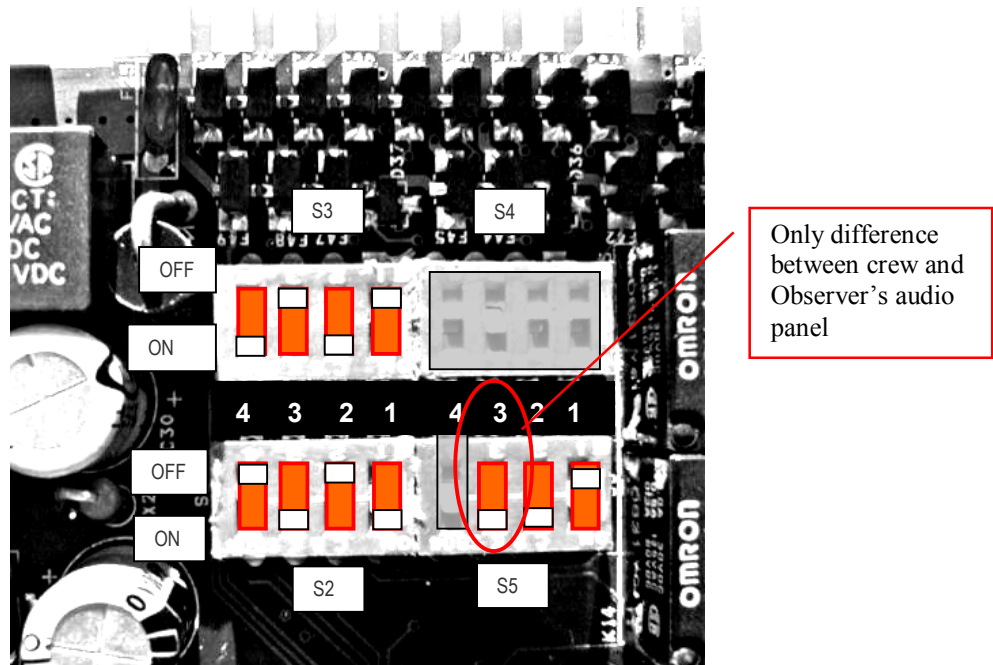

Figure 15 Switch positions, Dual PAC24 Observer, Observer's panel

Refer to Section [4.0](#) for settings of S4 and S5, Switch 4.

[NOTE: Circuit Jumpers J4 and J5 MUST be configured as described in § 3.2](#)

5.2 PAC24 Observer Installation with Expansion

If up to six additional intercom positions are desired, an IntelliPax expansion unit, P/N 11606, can be interfaced with the Observer's audio panel. These intercom positions will be heard in both crew and observer panels, unless the intercom is in "Crew" mode.

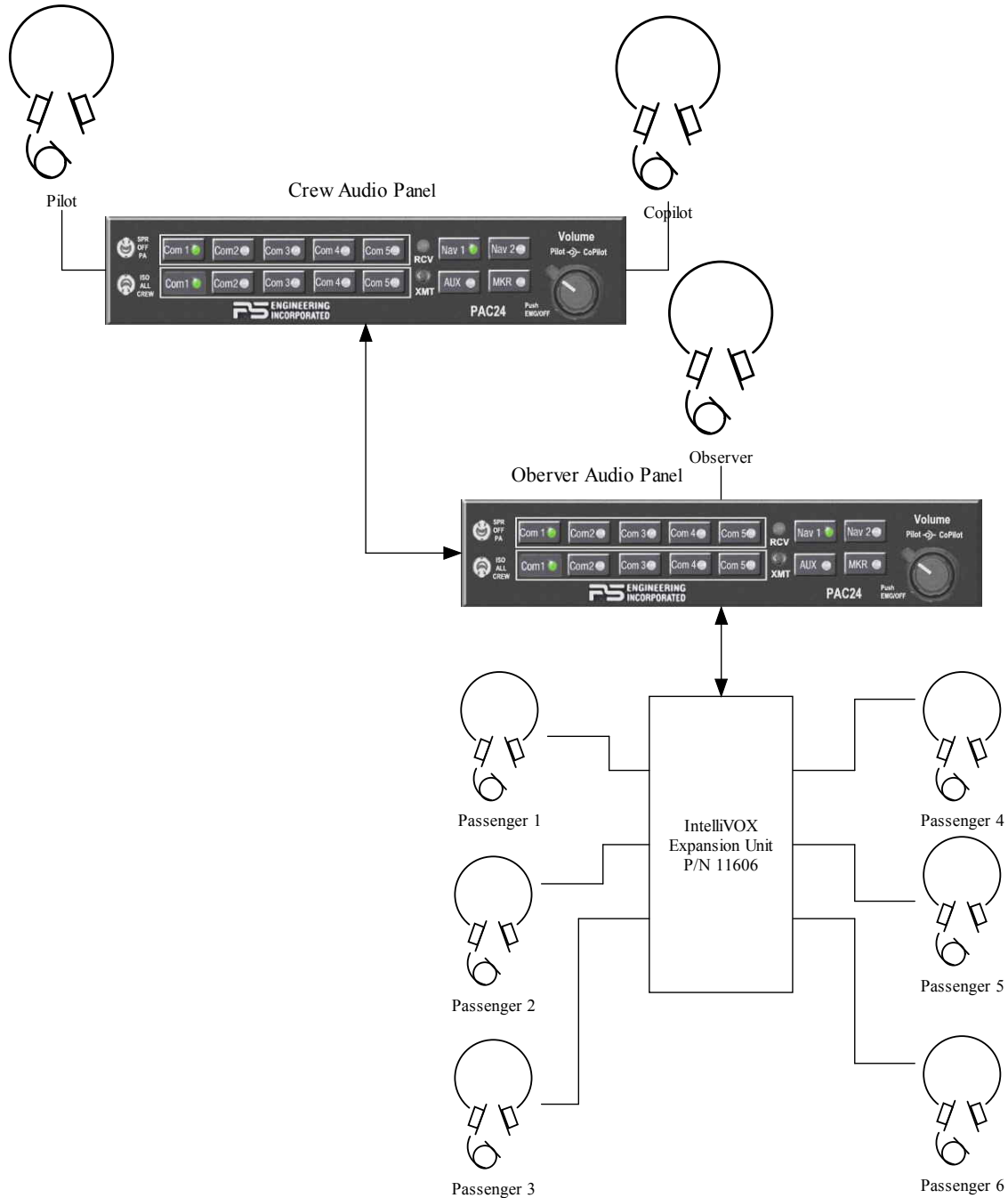

Figure 16 Diagram of PAC24 Observer configuration with 6-place expansion

5.2.1 PAC24 Observer version with Expansion, Crew's audio panel

S2		S3	
Switch 1	On	Switch 1	On
Switch 2	Off	Switch 2	Off
Switch 3	Off	Switch 3	Off
Switch 4	On	Switch 4	On
S5			
Switch 1	On		
Switch 2	On		
Switch 3	Off		

Table 13 Switch Settings, Dual PAC24 Observer with expansion, Crew's panel

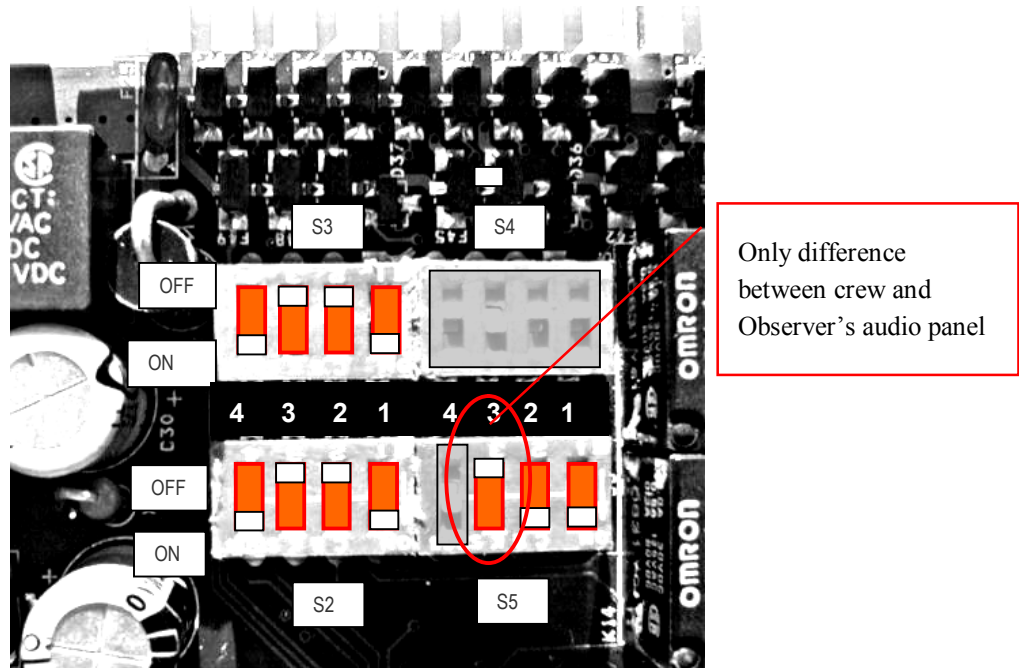

Figure 17 Switch positions, Dual PAC24 Observer with expansion, Crew's panel

Refer to Section [4.0](#) for settings of S4 and S5, Switch 4.

NOTE: Circuit Jumpers J4 and J5 MUST be configured as described in § 3.1

5.2.2 PAC24 Observer version (-0400), **Observer's panel.**

S2		S3	
Switch 1	On	Switch 1	On
Switch 2	Off	Switch 2	Off
Switch 3	Off	Switch 3	Off
Switch 4	On	Switch 4	On
S5			
Switch 1	On		
Switch 2	On		
Switch 3	On		

Table 14 Switch Settings, Dual PAC24 Observer with expansion, **Observer's panel**

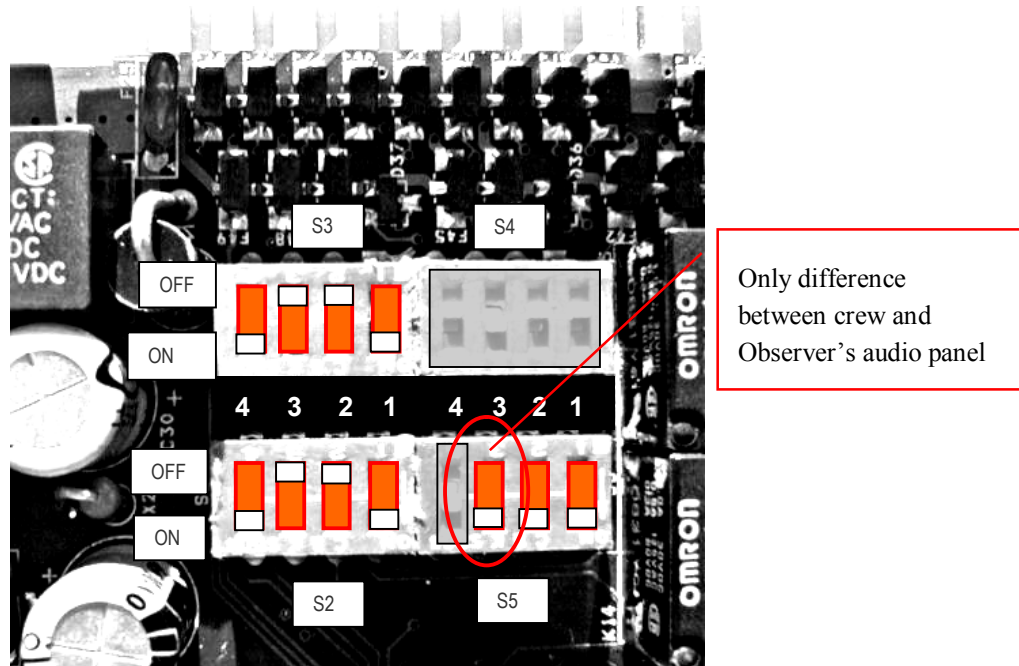

Figure 18 Switch positions, Dual PAC24 Observer with expansion, **Observer's panel**

Refer to Section [4.0](#) for settings of S4 and S5, Switch 4.

[NOTE: Circuit Jumpers J4 and J5 MUST be configured as described in § 3.2](#)

6.0 DIP Switch Cross reference.

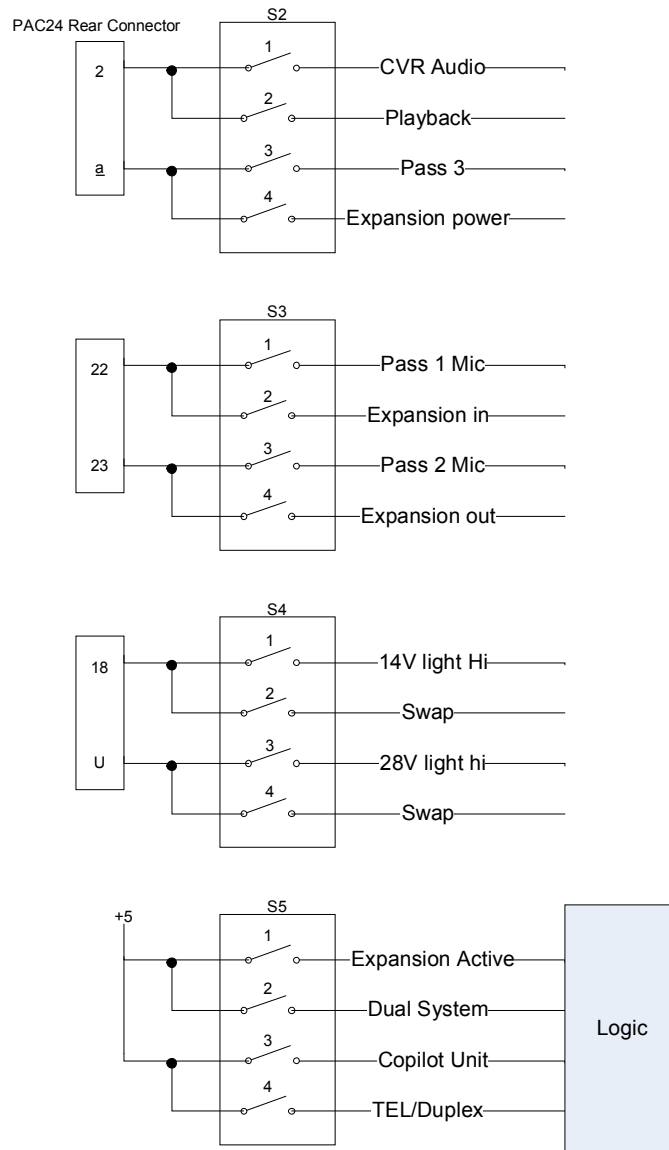

Figure 19 DIP Switch Schematic representation

6.1 DIP Switch tables by configuration

Single Installation- 28 Volt Aircraft					Single panel with Expansion - 28 Volt Aircraft				
	SW2	SW3	SW4	SW5		SW2	SW3	SW4	SW5
1	ON	ON	OFF	OFF	1	OFF	OFF	OFF	ON
2	OFF	OFF	ON	OFF	2	ON	ON	ON	OFF
3	ON	ON	ON	OFF	3	OFF	OFF	ON	OFF
4	OFF	OFF	OFF	See notes	4	ON	ON	OFF	See notes
J4- On/ J5- Pins 1 & 2					J4- On/ J5- Pins 1 & 2				

Table 6-1 Single Audio Panel DIP switch settings

Dual PAC24 - Pilot Panel- 28 Volt Aircraft					Dual PAC24- Copilot Panel- 28 Volt Aircraft				
	SW2	SW3	SW4	SW5		SW2	SW3	SW4	SW5
1	ON	ON	OFF	OFF	1	ON	ON	OFF	OFF
2	OFF	OFF	ON	ON	2	OFF	OFF	ON	ON
3	ON	ON	ON	OFF	3	ON	ON	ON	ON
4	OFF	OFF	OFF	See notes	4	OFF	OFF	OFF	See notes
J4- On/ J5- Pins 1 & 2					J4- Off J5- Pins 2 & 3				

Table 6-2 Dual Audio Panel DIP Switch Settings without expansion

Dual PAC24 with Expansion- Pilot Panel- 28 Volt Aircraft					Dual PAC24 with Expansion- Copilot Panel- 28 Volt Aircraft				
	SW2	SW3	SW4	SW5		SW2	SW3	SW4	SW5
1	ON	OFF	OFF	ON	1	ON	OFF	OFF	ON
2	OFF	ON	ON	ON	2	OFF	ON	ON	ON
3	OFF	OFF	ON	OFF	3	OFF	OFF	ON	ON
4	ON	ON	OFF	See notes	4	ON	ON	OFF	See notes
J4- On/ J5- Pins 1 & 2					J4- Off/ J5- Pins 2 & 3				

Table 6-3 Dual Audio Panel DIP Switch Settings with expansion

Dual PAC24 Observer- Cockpit Panel- 28 Volt Aircraft					Dual PAC24 Observer- Observer Panel- 28 Volt Aircraft				
	SW2	SW3	SW4	SW5		SW2	SW3	SW4	SW5
1	ON	OFF	OFF	OFF	1	ON	OFF	OFF	OFF
2	OFF	ON	ON	ON	2	OFF	ON	ON	ON
3	ON	OFF	ON	OFF	3	ON	OFF	ON	ON
4	OFF	ON	OFF	See notes	4	OFF	ON	OFF	See notes
J4 - On/ J5- Pins 1 & 2					J4 - Off/ J5- Pins 2 & 3				

Table 6-4 Dual Audio Panel with Observer Function, DIP switch settings

Dual PAC24 Observer w Expansion- Cockpit Panel- 28 Volt Aircraft					Dual PAC24 Observer w Expansion- Observer Panel- 28 Volt Aircraft				
	SW2	SW3	SW4	SW5		SW2	SW3	SW4	SW5
1	ON	OFF	OFF	ON	1	ON	OFF	OFF	ON
2	OFF	ON	ON	ON	2	OFF	ON	ON	ON
3	OFF	OFF	ON	OFF	3	OFF	OFF	ON	ON
4	ON	ON	OFF	See notes	4	ON	ON	OFF	See notes
J4- On/ J5- Pins 1 & 2					J4- Off/ J5- Pins 2 & 3				

Table 6-5 Dual Audio Panel with observer and with Expansion

General Notes

- If telephone is connected, turn SW5-4 to ON for all panels. Otherwise set it to OFF
- For 14V aircraft, change SW4 1-4 to ON, OFF, OFF, ON
- For CVR output, change SW2 1-2 to ON, OFF. NOTE: IRS cannot be used
- For IRS, change SW2 1-2 to OFF, ON. NOTE: CVR cannot be used