



9800 Martel Road  
Lenoir City, TN 37772

**PXE7300-SR**  
High-fidelity Stereo  
In-Flight Entertainment System  
With MP3/Compact Disc Player  
AM/FM Radio Receiver  
With Satellite Radio Option



**FAA-STC/PMA Approved**

Document P/N 200-739-0001  
Revision 2  
January 2005



**Installation and Operation Manual**

**In certified aircraft, warranty is not valid unless this product is installed by an Authorized PS Engineering dealer.**

**PS Engineering, Inc. 2005 ©**  
*Copyright Notice*  
Any reproduction or retransmittal of this publication, or any portion thereof, without the expressed written permission of PS Engineering, Inc. is strictly prohibited. For further information contact the Publications Manager at PS Engineering, Inc., 9800 Martel Road, Lenoir City, TN 37772. Phone (865) 988-9800.

Table of Contents

<b>SECTION I GENERAL INFORMATION</b> .....	<b>1-1</b>
<b>1.1 INTRODUCTION</b> .....	<b>1-1</b>
<b>1.2 SCOPE</b> .....	<b>1-1</b>
<b>1.3 EQUIPMENT DESCRIPTION</b> .....	<b>1-1</b>
<b>1.4 APPROVAL BASIS</b> .....	<b>1-1</b>
<b>1.5 SPECIFICATIONS</b> .....	<b>1-2</b>
<b>1.6 EQUIPMENT SUPPLIED</b> .....	<b>1-3</b>
<b>1.7 EQUIPMENT REQUIRED BUT NOT SUPPLIED</b> .....	<b>1-3</b>
<b>1.8 APPROVED AUDIO SYSTEMS</b> .....	<b>1-4</b>
<b>1.9 LICENSE REQUIREMENTS</b> .....	<b>1-4</b>
<b>1.10 SUBSCRIPTION REQUIREMENTS (OPTION SR ONLY)</b> .....	<b>1-4</b>
<b>SECTION II - INSTALLATION</b> .....	<b>2-1</b>
<b>2.1 GENERAL INFORMATION</b> .....	<b>2-1</b>
2.1.1 SCOPE .....	2-1
<b>2.2 UNPACKING AND PRELIMINARY INSPECTION</b> .....	<b>2-1</b>
<b>2.3 EQUIPMENT INSTALLATION PROCEDURES</b> .....	<b>2-1</b>
2.3.1 COOLING REQUIREMENTS .....	2-1
2.3.2 MOUNTING REQUIREMENTS .....	2-1
2.3.3 PXE7300 MOUNTING RACK INSTALLATION .....	2-2
2.3.4 CONNECTOR ASSEMBLY .....	2-3
<b>2.4 CABLE HARNESS WIRING</b> .....	<b>2-3</b>
2.4.1 NOISE .....	2-3
2.4.2 POWER.....	2-4
2.4.3 BACKLIGHTING .....	2-4
2.4.4 AM/FM ANTENNA .....	2-4
2.4.5 UNSWITCHED SUMMED AUDIO .....	2-5
2.4.6 AUX ENTERTAINMENT AUDIO AND AUX ENABLE .....	2-5
<b>2.5 INTERNAL ADJUSTMENTS</b> .....	<b>2-5</b>
<b>2.6 PSM7390 SIRIUS MODULE INSTALLATION</b> .....	<b>2-5</b>
2.6.1 MOUNTING RACK INSTALLATION .....	2-5
2.6.2 SATELLITE RADIO ANTENNA INSTALLATION .....	2-6
<b>2.7 POST INSTALLATION CHECKOUT</b> .....	<b>2-7</b>
<b>2.8 UNIT INSTALLATION</b> .....	<b>2-7</b>
2.8.1 SYSTEM CHECKOUT .....	2-7
2.8.2 SIRIUS MODULE CHECKOUT .....	2-8
<b>2.9 FINAL INSPECTION</b> .....	<b>2-9</b>
<b>SECTION III OPERATION</b> .....	<b>3-1</b>
<b>3.1 SCOPE</b> .....	<b>3-1</b>
<b>3.2 OPERATING CONTROLS</b> .....	<b>3-1</b>
3.2.1 POWER/VOLUME CONTROL (1).....	3-1
3.2.2 STOP/EJECT BUTTON (2) .....	3-1
3.2.3 PLAY/PAUSE BUTTON (3).....	3-1
3.2.4 THE R/S BUTTON (4).....	3-2
3.2.5 THE DATA KNOB (5) .....	3-2
3.2.6 THE MODE BUTTON (6).....	3-2

**3.3 RADIO RECEPTION ..... 3-2**

**3.4 RADIO PRESET FUNCTION..... 3-2**

**3.5 SIRIUS MODULE OPERATION..... 3-3**

3.5.1 SIRIUS SIGNAL DROP OUT: ..... 3-4

**3.6 DISPLAY DIMMING (7)..... 3-4**

**SECTION IV- WARRANTY AND SERVICE..... 4-1**

**4.1 WARRANTY ..... 4-1**

**4.2 FACTORY SERVICE ..... 4-1**

**APPENDIX A – MP3 CREATION ..... A**

**5.1 CREATING MP3S FROM AN AUDIO CD..... A**

**APPENDIX B – INSTALLATION DRAWINGS ..... B**

**APPENDIX C CONNECTOR INTERCONNECT..... C**

**APPENDIX D- STC INFORMATION AND INSTRUCTIONS FOR CONTINUING AIRWORTHINESS ..... D**

**8.1 INSTRUCTIONS FOR FAA FORM 337, PXE7300-SR ..... D**

**8.2 INSTRUCTIONS FOR CONTINUING AIRWORTHINESS, PXE7300 SYSTEM..... D**

**8.3 MASTER DRAWING LIST ..... D**

**8.4 USE OF APPROVED MODEL LIST ..... D**

**APPENDIX E RTCA DO160D/EUROCAE ED-14D ENVIRONMENTAL QUALIFICATION FORM..... E**

*Table of Figures*

Figure 2-2 Avionics Mounting Rails (Typical) ..... 2-2

Figure 2-3 Completed panel opening (Typical) ..... 2-3

Figure 3-1 PSM7390 Installation ..... 2-6

Figure 3-2 SR mounting Tray Hole Pattern ..... 2-6

Figure 3-3 Typical Antenna Installation..... 2-7

Figure 3-1 Front Panel Controls..... 3-1

Figure 7-1 Panel Location Drawing (Typical) 120-973-8801 ..... B

Figure 7-2 PXE7300 Installation Diagram (Typical) 120-974-2488 ..... C

Figure 7-3 Tray Installation Drawing, 002-973-0430 ..... D

Figure 7-4 - Satellite Radio Antenna Mounting NOT TO SCALE (120-230-2488)..... E

Figure 7-5 Circuit breaker installation drawing 120-973-8802 (typical) ..... F

Revision History

Rev	By	Date	Revision
1	GLP	2/2004	New STC release SA02795AT
2	GLP	1/2005	Added text regarding SIRIUS Satellite Radio signal availability

## Section I GENERAL INFORMATION

### 1.1 INTRODUCTION

Quality cockpit and cabin entertainment has long been an elusive dream in general aviation. Whether it was marginal performance or unapproved parts, pilots couldn't enjoy the same music in their aircraft as they could in the family car. The marketplace needed a product designed, built and manufactured for general aviation.

The PXE7300-Series represents such a product. This one unit combines a compact disk (CD) player with MP3 capability and an AM/FM radio for ultimate in-flight entertainment capability.

The optional SIRIUS satellite Radio Module provides over 100 audio streams of entertainment, most of them commercial free. These signals are available anywhere over the contiguous United States, so you won't lose your favorite station in flight.

Before installing and/or using this product, please read this manual completely. This will ensure that you will take full advantage of all the advanced features in the PXE7300.

### 1.2 SCOPE

This manual provides detailed installation and operation instructions for the PS Engineering PXE7300-series of IFE Systems. This includes the following units:

Model	Part Number	Description
PXE7300-SR	11970 Option -SR	SIRIUS Satellite Radio receiver option

Where the functions are identical to all units, it will be referred to herein as a PXE7300. Otherwise, the applicable units will be specified.

### 1.3 EQUIPMENT DESCRIPTION

The PXE7300 System is a single panel mounted unit that contains a CD player with MP3 media capability and an AM/FM radio receiver. It also contains a high-fidelity stereo amplifier to provide the entertainment output to the aircraft audio system.

An 8-digit LED display provides information about the systems, modes, and media in use.

### 1.4 APPROVAL BASIS

The PXE7300 is FAA approved FAA-STC SA02795AT and manufactured under PMA. PQ1336CE.

All systems comply with relevant portions of EUROCAE ED-14D/DO-160D (*Environmental Conditions and Test Procedures for Airborne Equipment*), ED12B/DO-178B (*Software Considerations for Airborne Equipment*) and ED- 18/DO-214 (*Audio Systems Characteristics and Minimum Operational Performance Standards for Aircraft Audio Systems*).

STC SA02795AT can be used as a basis for approval in other aircraft provided the generic installation manual, Document Number 200-739-0001 or later approved revision, is followed.

Advisory Circulars AC43.13-1B Acceptable Methods, Techniques, and Practices - Aircraft Inspection and Repair, and 43.13-2A - Acceptable Methods, Techniques, And Practices - Aircraft Alterations are to be used to resolve any issues not specifically addressed by the Installation Manual. Instructions for Continuing Airworthiness (ICA) are provided in the supplied data.

Operation is subject to the following conditions:

This device may not cause harmful interference.

This device must accept any interference received, including interference that may cause undesired operation.

**1.5 SPECIFICATIONS**

<b>FAA-PMA COMPLIANCE</b>	
APPLICABLE DOCUMENTS:	RTCA/DO-214 RTCA/DO-160D RTCA/DO-178B (Level E)
ENVIRONMENTAL Qualifications:	B1CABSXXXXXXXXZBBBAUHXXX
<i>Temperature Range:</i> Operating: Storage:	-15° C to 55° C -40° C to 85° C
<i>Altitude:</i>	Up to 25,000 feet in a non-pressurized area of the cockpit.
DIMENSIONS:	Height: 2.0 in. (5.1 cm) Width: 6.25 in. (15.9 cm) Depth: 7.7 in. (19.8 cm)
WEIGHT (With Rack & Connectors):	2.6 lb. (1.2 kg)
<b>POWER REQUIREMENTS (Including Internal Lighting):</b>	
<i>Voltage:</i>	11 to 33 VDC
<i>Maximum Current:</i> 11970 11971	1.5 Amp (Externally protected by a 2 Amp circuit pull-type breaker.) 2.5 A (Externally protected by a 5 Amp circuit pull-type breaker.)
<i>Typical operating current:</i> Lighting Current	800 mA 5 mA
<b>Audio Specifications</b>	
<i>Output Impedance:</i>	150 - 1000 Ω
<i>Audio Output:</i>	38 mW each channel, no clipping <1% THD
<i>Distortion:</i>	<1% THD
<i>Music Freq. Response, 3 dB:</i>	14 Hz –22 kHz
<b>FCC Type Acceptance</b>	
<i>Part 15</i>	Verification to Part 15
<b>Radio Tuning</b>	
<i>North America</i>	AM: 530 – 1710 kHz, 10 kHz steps FM: 87.7 – 107.9 MHz, 200 kHz steps
<i>European (Option E)</i>	AM: 531 - 1602kHz, 9kHz steps FM: 87.5 - 107.9MHz, 100kHz steps
<b>PSM7390 SIRIUS Module</b>	
DIMENSIONS:	Height: 5.5 in. (14.0 cm) Width: 1.50 in. (3.8 cm) Depth: 7.75 in. (19.7 cm)
WEIGHT (With Rack & Connectors):	2.6 lb. (1.2 kg)
<b>POWER REQUIREMENTS:</b>	
<i>Voltage:</i> <i>Maximum Current</i>	11 to 33 VDC 0.9 Amp (Power provided by PXE7300-SR Unit)

**1.6 EQUIPMENT SUPPLIED**

1 ea. of the following units:

**SIRIUS Radio Option, PXE7300-SR**

Model	Part Number	Description
PXE7300-SR	11970, Option SR	IFE System for use with SIRIUS Radio Module

PXE7300 Installation Kit: 250-730-0001

Part Number	Description	Quantity
430-730-0020	Tray	1
430-730-0025	Tray Shield	1
120-425-4402	44 Pin Connector Key 4/5	1
425-001-0002	Gold Plated Crimp Pins	30
475-440-0007	4-40x7/16" Phil-Pan w/Nylon Patch	4
475-630-0002	6-32 Clip Nut	6
475-632-0012	6-32 x 1/2 Phil-flat screws	6
202-730-00XX	Pilots Guide	1
510-730-0001	Passive AM/FM Antenna	1

**1.6.1 SIRIUS Radio Module**

Model	Part Number	Description
PSM7390	010-731-1030	SIRIUS Radio Module

**1.6.2 SIRIUS Radio Module Kit: 250-973-0500**

430-739-5000	Mounting rack	1
475-739-5268	Mounting Screws, #8-32 x 1/2"	6
475-739-9600	Washers #8	12
475-739-0832	Self Locking Nuts, #8	6
425-000-1310	Satellite Antenna Connector (Blue) RG316	1
425-012-1759	Connector Housing (12 position)	1
425-040-1739	Connector Pins	8

**1.7 EQUIPMENT REQUIRED BUT NOT SUPPLIED**

- a) Circuit Breaker, PULL TYPE: 1 ea. 5A
- b) Aircraft Audio System (See section 1.8 for approved system list)
- c) Interconnect Wiring
- d) SIRIUS Satellite Radio Antenna (Antenna Specialists AT2300 PS E part Number 510-739-2300, or equiv).

For antenna installation:

Doubler plate, p/n 430-230-2488, or equiv.

4 ea. #6-32 screws AN520 (or equiv.) SS PPHD

4 ea. #6 flat washer AN960 (or equiv.)

4 ea. #6-32 locking nuts (may be part of doubler plate or backing plate) MS21042-06 (or equiv.)

Silicone sealer or other aviation type sealer

SMA Antenna Connector: PS P/N, 425-000-2211, Mfr P/N Tyco 221117-2

Pre-made SIRIUS Antenna Cable: 010-0316-0010 (10' cable)

010-0316-0020 (20' cable)

**1.8 APPROVED AUDIO SYSTEMS**

This is a list of audio system that the PXE7300 should interface with adequately.

*Approved Audio Systems, PXE7300*

Certified interface is approved only for audio systems that are FAA-TSO approved.

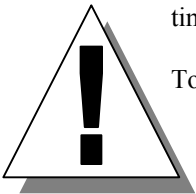
Make	Model	Part Number
PS Engineering	PM1000II	11920,11922
	PM3000	11931, 11932
	PMA6000-Series	6000 (all)
	PMA7000-Series	7000 (all)
	PCD7100	11950, 11951
	PMA4000	11942
	PAC24	050-240-(all)
GARMIN AT	SL10-Series	430-6060-XX
	SL15-Series	430-6065-XX
Bendix/King	KMA28	066-01176-0101
GARMIN International	GMA340	010-00152-XX

**1.9 LICENSE REQUIREMENTS**

None

**1.10 SUBSCRIPTION REQUIREMENTS (Option SR Only)**

The SIRIUS Satellite Receiver requires an activation and periodic subscription. Monthly, annual and life-time plans are available.



To activate the module, you will need to do the following:

- The SID/ESN number from your SIRIUS receiver.
- A major credit card.
- The SIRIUS tuner installed, the aircraft outside with a clear view of the sky.
- Turn your SIRIUS tuner on and tune it to channel 184.



When you activate online you pay only \$5.00 at [www.sirius.com](http://www.sirius.com). If you choose to activate by phone the charge is \$15. You can either call 1.888.539.SIRIUS (7474) or activate online.

Keep in mind that there may be additional fees when you activate, based on the following criteria:

- \$5 charge to reactivate a receiver that has been inactive for over six months.
- \$5 late fee for monthly payments made after bill due date.
- Printed copies of account information less than 18 months old cost \$2.50 per request.
- Printed copies of account information more than 18 months old cost \$10 per request.
- Termination of service prior to the end of a prepaid subscription or committed subscription period will result in a \$75 cancellation fee. Fee does not apply for monthly plans.
- You are responsible for all taxes or other government fees and charges, if any, based on the address on your account.

NOTE: Prices subject to change without notice

**Record your Radio ID here for future reference.**

## Section II - Installation



### 2.1 GENERAL INFORMATION

**NOTE: RECORD SIRIUS RADIO BEFORE DISCARDING BOX OR INSTALLING MODULE.**  
Record the number in space provided on page 1-4, Section 1.10.

#### 2.1.1 SCOPE

These sections provide detailed installation and interconnect instructions for the PXE7300 In-Flight Entertainment System with integrated Compact Disc (CD/MP3) Media Player, AM/FM radio receiver and remote mounted SIRIUS Radio Module (PSM7390).

Please read this manual carefully before beginning any installation to prevent damage and post-installation problems. Installation of this equipment requires special tools and knowledge.

#### **NOTE:**

**An appropriately rated Certified Aircraft Repair Station must install this equipment in accordance with applicable regulations. PS Engineering, Incorporated warranty is not valid unless the equipment is installed by an authorized PS Engineering, Incorporated dealer. Failure to follow any of the installation instructions, or installation by a non-certified individual or agency will void the warranty, and may result in an unairworthy installation.**

### 2.2 Unpacking and Preliminary Inspection

Use care when unpacking the equipment. Inspect the units and parts supplied for visible signs of shipping damage. Examine the unit for loose or broken buttons, bent knobs, etc. Verify the correct quantity of components supplied with the list in Section 1.6 (B). If any claim is to be made, save the shipping material and contact the freight carrier. Do NOT return units damaged in shipping to PS Engineering. If the unit or an accessory shows any sign of external shipping damage, contact PS Engineering to arrange for a replacement. Under no circumstances attempt to install a damaged unit in an aircraft. Equipment returned to PS Engineering for any other reason should be shipped in the original PS Engineering packaging, or other UPS approved packaging.

### 2.3 Equipment Installation Procedures

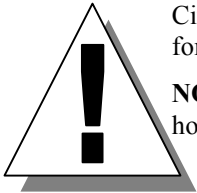
#### 2.3.1 Cooling Requirements

Forced air-cooling of the PXE7300 and PSM7390 are not required. However, the unit should be kept away from heat producing sources (i.e. defrost or heater ducts, dropping resistors, heat producing avionics) without adequate cooling air provided.

#### 2.3.2 Mounting Requirements

The PXE7300 must be rigidly mounted to the instrument panel or other structure of the aircraft structure and within view and reach of the persons wishing access. Installation must comply with FAA Advisory Circular AC 43.13-2A (or later revision). The unit may be mounted in any area where adequate clearance for the unit and associated wiring bundle exist.

**NOTE:** The PXE7300 unit must be installed within  $\pm 30^\circ$  of horizontal along the pitch axis, and  $\pm 10^\circ$  of horizontal along the roll axis in level flight.





Avoid installing the PXE7300 close to high current devices or systems with high-voltage, pulse type outputs, such as DME or transponders.

The PSM7390 must be rigidly mounted to the aircraft structure in an area where avionics are typically installed, in accordance with FAA Advisory Circular AC 43.13-2A (or later revision) Chapter 2, Section 24, and this manual.

### 2.3.3 PXE7300 Mounting Rack Installation

Remove the unit from the mounting tray by unscrewing the 3/32" hex-head screw that is near the left edge of the unit. Carefully slide the unit free of the tray. Set the unit aside in a safe location until needed. Install the tray using six FHP 6-32 x 1/2" screws. The unit must be supported at front and rear of the mounting tray. See Appendix B.

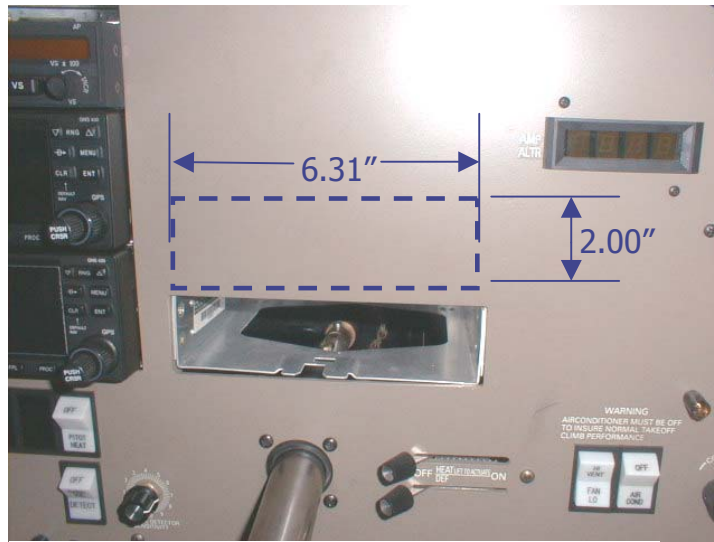


Figure 2-1 Typical Panel Unit Installation Location

The tray mounting can be made in any area that exists for adding additional avionics. Instrument panel mounting is accomplished in accordance with AC 43.13-2A, Chapter 2.

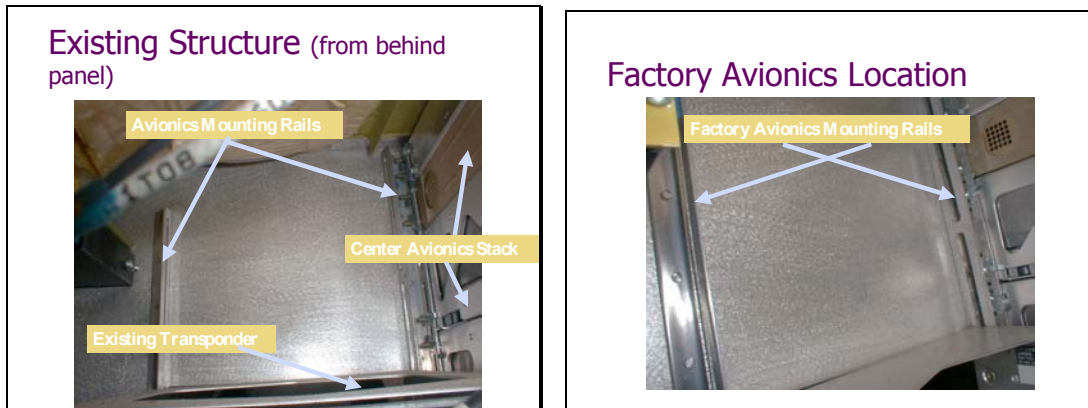
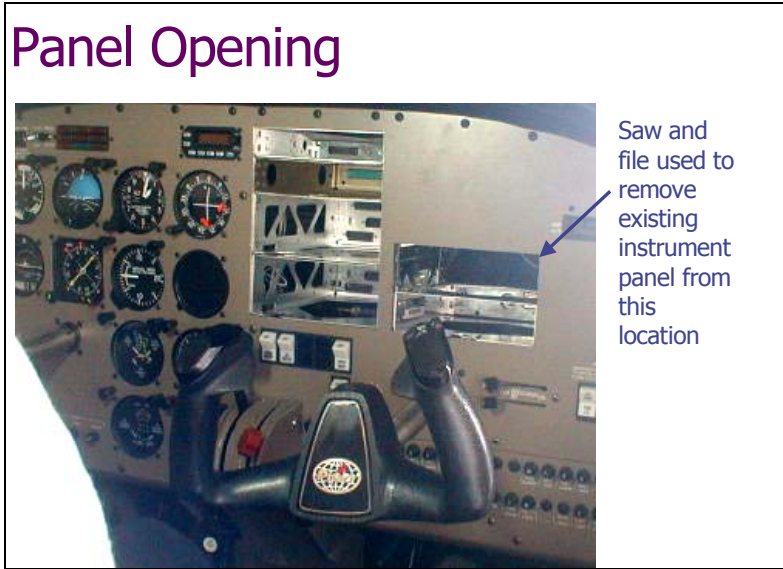


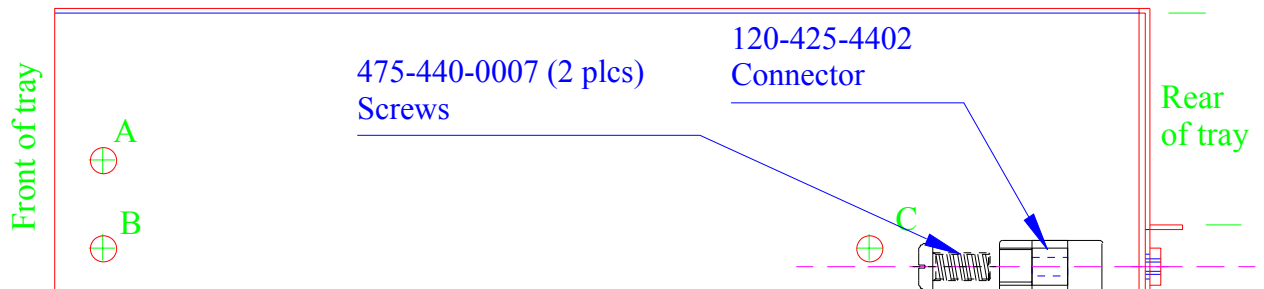
Figure 2-2 Avionics Mounting Rails (Typical)



**Figure 2-3 Completed panel opening (Typical)**

### 2.3.4 Connector Assembly

The unit connector mates directly with the circuit boards in the PXE7300. The connector (part number 120-425-4402 is a Molex crimp-type, and requires the use of a Molex hand crimp tool, EDP P/N 11-01-0203, CR6115B (or equiv.). The connector is mounted to the unit tray with 2 ea. #4-40 screws, from the inside of the tray. Ensure that proper strain relief and chafing precautions are made during wiring and installation.



## 2.4 Cable Harness Wiring

Referring to the appropriate Appendix, assemble a wiring harness as required for the installation. All wires must be MIL-SPEC in accordance with current regulations. Two- and three-conductor shielded wire must be used where indicated, and be MIL-C-27500 or equivalent specification. Proper stripping, shielding and soldering technique must be used at all times. It is imperative that correct wire be used.

Refer to FAA Advisory Circular 43.13-1B and 2A for more information. Failure to use correct techniques may result in improper operation, electrical noise or unit failure. Damage caused by improper installation will void the PS Engineering warranty. PS Engineering can provide a custom made harness, visit [www.ps-engineering.com](http://www.ps-engineering.com) for more information.

### 2.4.1 Noise

Due to the variety and the high power of radio equipment often found in today's general aviation aircraft, there is a potential for both radiated and conducted noise interference.

**PS Engineering**  
PXE7300-SR IFE System  
Installation and Operator's Manual

The PXE7300 power supply is specifically designed to reduce conducted electrical noise on the aircraft power bus by at least 50dB. Although this is a large amount of attenuation, it may not eliminate all noise, particularly if the amplitude of noise is very high. There must be at least 12 VDC present at the connector pin 21, of the PXE7300 for the power supply to work in its designed regulation. Otherwise, it cannot adequately attenuate power line noise. Shielding can reduce or prevent radiated noise (i.e., beacon, electric gyros, switching power supplies, etc.) However, installation combinations can occur where interference is possible. The PXE7300 was designed in a RFI hardened chassis and has internal Electromagnetic Interference (EMI) filters on all inputs and outputs.

Ground loop noise occurs when there are two or more ground paths for the same signal (i.e., airframe and ground return wire). Large cyclic loads such as strobes, inverters, etc., can inject noise signals onto the airframe that are detected by the audio system. Follow the wiring diagram very carefully to help ensure a minimum of ground loop potential. Use only Mil Spec shielded wires (MIL-C-275000, or better).

### 2.4.2 Power

The PXE7300-Series units are compatible with both 14 and 28 Volt DC systems. A five (5) Amp PULL-TYPE breaker is required for PXE7300-SR. Power and ground wires must be a twisted #18 AWG pair. Connect airframe power ground to Pin 22 only.

See Appendix B for typical circuit breaker layout.



Figure 2-4 Circuit breaker location (Typical)

### 2.4.3 Backlighting

The PXE7300 has an automatic dimming of the pushbutton annunciator LEDs controlled by a photocell. A dimmer control allows the bezel text backlighting to be controlled by the aircraft dimmer. Connect the 14 V dimmer control to pin 1, the 28 V dimmer to pin A, as required, using #22 AWG as a minimum size.

### 2.4.4 AM/FM Antenna

The passive AM/FM antenna, part number 510-730-0001 (included) is optimized for FM radio performance. Therefore, when used for AM reception, the operator may only receive the most powerful 3 to 5 AM stations. In contrast to an ADF, where audio fidelity is not important, the PXE7300 requires higher signal levels to ensure fidelity.

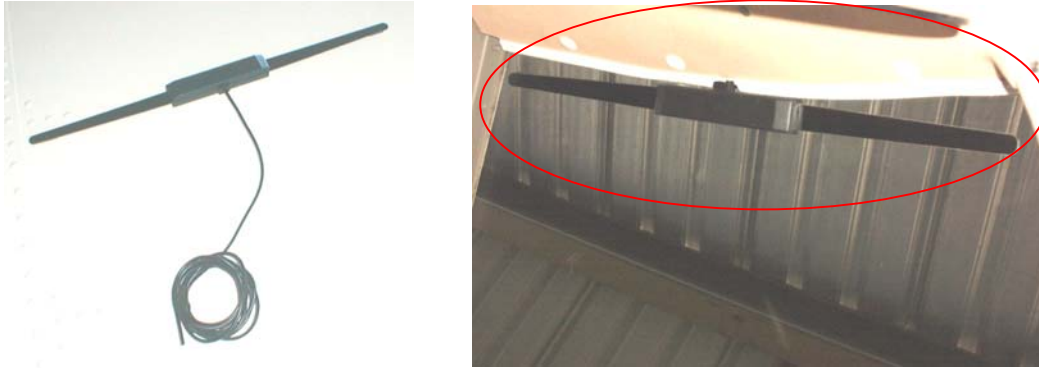
For optimum performance, some installers may desire an external AM/FM antenna. PS Engineering recommends a Comant CI-222-series, installed in accordance with AC43.13-1A, Chapter 3.

Another AM performance-enhancing alternative is to connect the PXE7300 antenna input to an unused VOR port of the VHF NAV antenna splitter. Do NOT add another splitter in series.



The included antenna can be mounted wherever convenient inside the cockpit, as long as it is in a window. Verify that the antenna is not an impediment to crew vision outside the cockpit when installed,

For optimal operation, it should be near the windshield. Clean the mounting surface with appropriate means (glass cleaner, etc), and apply adhesive (supplied with antenna). Route the antenna cable along edge to the glareshield, and then connect to the PXE7300 connector. Avoid running the antenna cable near high-current carrying wires, such as windshield heat, etc.



**Figure 2-5 Antenna Installation**

The antenna cable center conductor is connected to Pin 2, braid is connected to pin B.

#### **2.4.5 Unswitched Summed Audio**

PXE7300 units have four audio inputs that are summed together and presented to the audio output, J1 pin 18 WRT V.

NOTE: These can be used to implement additional audio warnings when connected to the appropriate Unswitched audio input of an audio panel. This includes Autopilot warnings, TAWS, GPS alerts, Radio Altimeter, etc.

#### **2.4.6 Aux Entertainment Audio and AUX Enable**

Besides the disc and AM/FM, the PXE7300 has the ability to act as a switching control for an additional entertainment input (DVD, external XM Radio tuner, etc.).

The audio input is Pin 16 (R), Pin 17 (L) with respect to Pin K.

To enable the mode, add an internal jumper on the pins marked J2, or apply a ground to Pin 20 of the rear connector.

#### **2.5 Internal Adjustments**

None

### **2.6 PSM7390 SIRIUS Module Installation**

The PSM7390 SIRIUS Radio Module is a remote-mounted unit. This should be located in an area designed for remote avionics.

#### **2.6.1 Mounting Rack Installation**

Attach the mounting rack to the avionics shelf using six (6) #8 x 32 screws, locking washers and nuts. Or, install nut plates.

Make all installation in accordance with AC 43.13-2A Chapter 2, Section 24, or the aircraft maintenance manual, or other accepted technical data.

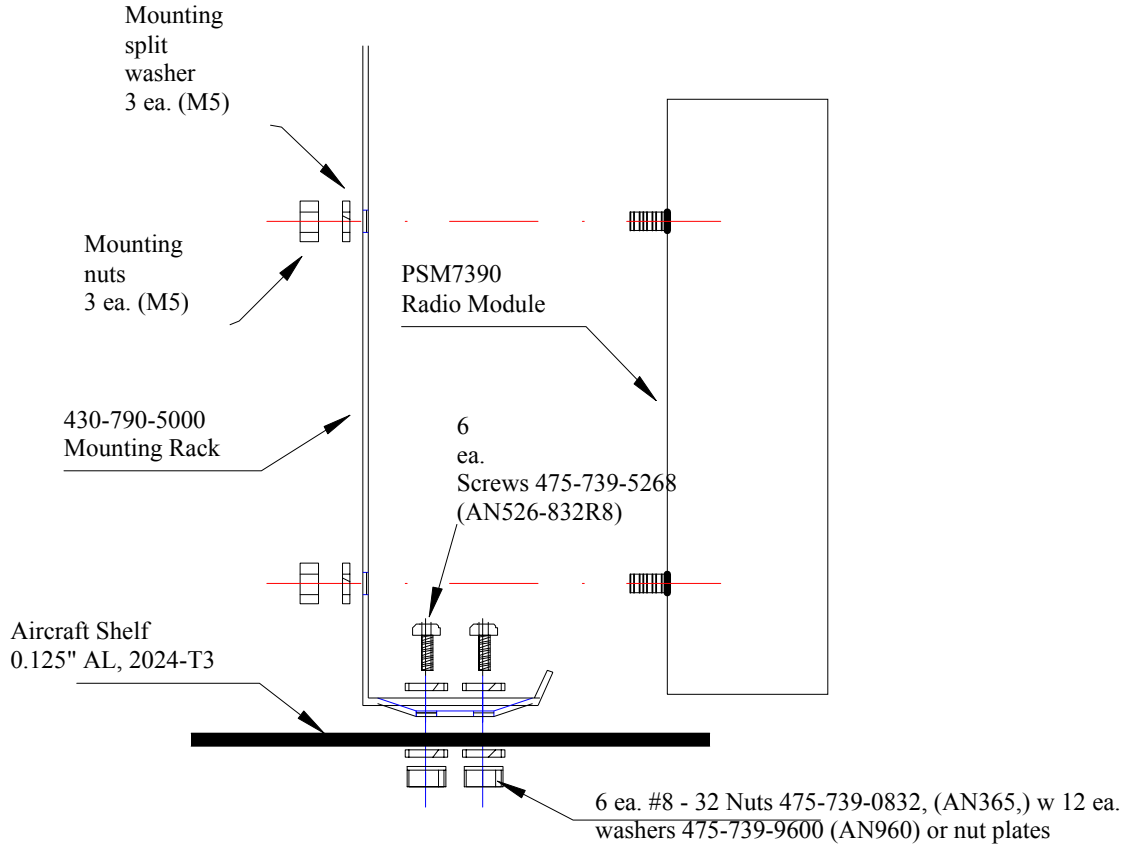


Figure 2-6 PSM7390 Installation

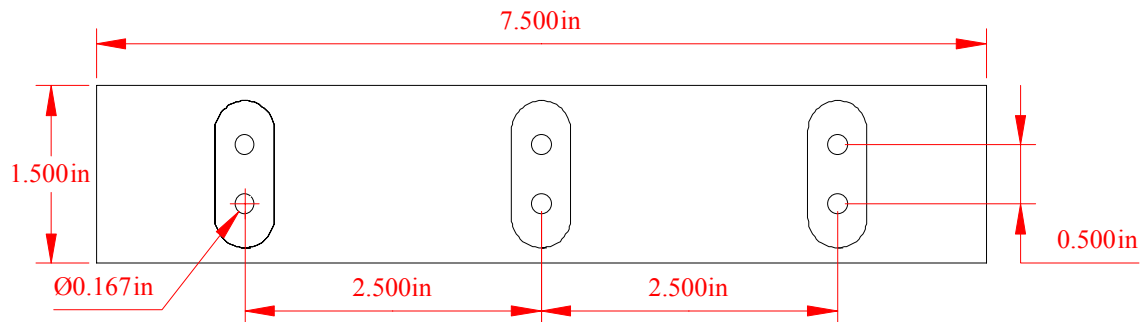


Figure 2-7 SR mounting Tray Hole Pattern

### 2.6.2 Satellite Radio Antenna Installation

Antenna must be installed in accordance aircraft manufacturer instructions if applicable. Install in accordance with antenna installation drawing 120-230-2488. Use doubler plate, p/n 430-230-2488, or equivalent.

Provide a stable mounting base for the antenna and provide adequate clearance for the connector. Use a backing plate or doubler plate as required by the installation to comply with FAA or aircraft manufacturers advisory information.

Insure a continuous contact between the antenna O-ring seal and aircraft skin.

Use silicone sealer between the antenna and the aircraft skin. Use four #6 stainless screws to secure antenna to aircraft, using silicone sealer to seal the screws.

When routing the coax, avoid sharp bends, kinking or placement near aircraft control, power DME, transponder or radio communications cables. Careful attention must be given when securing the coax to the airframe. Do not allow cable ties to crimp or crush the coax.

The antenna MUST be located on the top of the aircraft. Typically, the best location is on the aircraft centerline, as close to the receiver module as practical. Installation should be centered between stringers,  $\pm 1.0$  inch, with a minimum 1.0-inch spacing to the structure.



**Figure 2-8 Typical Antenna Installation**

Any shadowing or signal blockage from the aircraft will degrade the performance of the SRR receiver. Ideally, the antenna should have an unobstructed view of the sky above the horizon.

Coax cable loss not to exceed 7 dB. Select location to avoid interaction with other aircraft antennas. Mount at least 24 inches from VHF Com transmitter antennas, at least 6 inches from other antennae.

## **2.7 Post Installation Checkout**

After wiring is complete, verify power is ONLY on pin 21 of the connector, and airframe ground on bottom connector pin 22. Failure to do so will cause serious internal damage and void PS Engineering's warranty.

## **2.8 Unit Installation**

To install the PXE7300, gently slide the unit into the mounting rack until the hold-down screw is engaged. While applying gentle pressure to the face of the unit, tighten the 3/32" hex-head in the unit until it is secure. DO NOT OVER TIGHTEN.

**Warning:** Do not over-tighten the lock down screw while installing the unit in tray.  
**Internal damage will result.**

### **2.8.1 System Checkout**

1. Insert disc, and verify that the player accepts the disk with about  $\frac{1}{2}$  of the diameter in the unit. The player should pull the disk smoothly and drop into place.
2. The player will begin to play, automatically about 20 seconds (after reading the disc).

**PS Engineering**  
PXE7300-SR IFE System  
Installation and Operator's Manual

3. If the unit is in disc mode, with CD inside at power-up, it will play (after reading the disc).
4. Verify that all Disc modes operate.
5. Push the "Eject" button and verify that the disc is ejected within about 10 seconds.
6. Verify radio operation on AM and FM
7. Verify that aux audio is presented to the output (if connected).
8. Evaluate the audio interface to be certain that the IFE audio is muted during intercom and radio communication.
  - a. If muting override is provided, evaluate the switch location and verify operation.
  - b. Evaluate the audio performance
  - c. Evaluate the audio level to verify that the music is adequate under flight conditions.
  - d. Evaluate the muting system to demonstrate that the music will be adequately muted if desired, by radio and intercom.
  - e. Evaluate the muting override control if equipped.
9. Evaluate failure remediation from crewmember location
  - a. Turn unit off
  - b. Locate and pull unit circuit breaker
  - c. With the disc playing, with minimum volume, listen to the following audio sources (as equipped), adjusted to normal listening level:
    - i. Comm 1, comm. 2, comm 3, HF
    - ii. Nav 1, Nav 2
    - iii. ADF (1 and 2)
    - iv. DME (1 and 2)
    - v. Marker
    - vi. Any other audio sources
  - f. Select FM Mode, and repeat step 6, listening for interference on the aircraft audio sources.
10. Select AM Mode, and repeat step 6, listening for interference on the aircraft audio sources.
11. Select COM 1 for transmit. Tune COM 1 to 118.00, and the PXE7300 to 107.3 MHz. Transmit a test count and evaluate the unit display and audio output for inconsistencies
12. Repeat step 10 for COM 2, and other transmitters.
  - a. Tune Nav 1 to local station and perform a standard VOT test in accordance with 14 CFR 91.171.
  - b. Note the indicated VOR bearing on both systems.
  - c. Turn the PXE7300 on and off, and observe any change in the VOR indication that could be attributed to the PXE7300.

### **2.8.2 SIRIUS Module Checkout**

Position the aircraft with a clear view of the sky.

1. Turn on the PXE7300-SR and cycle the "Mode" until SR shown in the display.
2. Select SIRIUS Channel 184 (preview channel).
3. Verify that the no error message appears in the display, and a valid audio stream is detected. This may take a few minutes the first time the system is turned on.
4. Repeat step 8 in section 2.8.1.
5. Turn on all installed GPS systems, and verify that the signal levels do not degrade when the PXE7300-SR is turned on and off.

**SIRIUS SIGNAL DROP OUT:**

SIRIUS Satellite Radio uses ground-based transmitters in populated areas to ensure consistent road coverage. However, for airborne receivers, these ground-based signals may cancel satellite-transmitted signals, resulting in a dropped signal. You may experience interruptions in the airborne SIRIUS signal near large cities. This interruption will be variable, depending on AGL altitude, distance, number of ground-based transmitters and azimuth to the transmitters.

**PS Engineering, Inc. does not guarantee SIRIUS Satellite Radio coverage in all areas, or the suitability of the SIRIUS Satellite Radio for any particular geographical area.**

**2.9 Final Inspection**

Verify that the wiring is bundled away from all controls and no part of the installation interferes with aircraft control operation. Move all controls through their full range while examining the installation to see that no mechanical interference exists. Verify that the cables are secured to the aircraft structure in accordance with good practices, with adequate strain relief. Ensure that there are no kinks or sharp bends in the cables and coaxial cables. Verify that the cables are not exposed to any sharp edges or rough surfaces, and that all contact points are protected from abrasion.

Complete logbook entry, FAA Form 337, weight and balance computation and other documentation as required. Sample text for FAA Form 337 and instructions for continuing airworthiness can be found in Appendix F.

Return completed warranty registration application to PS Engineering.



## Section III OPERATION

### GENERAL INFORMATION



#### 3.1 SCOPE

This section describes the operation of the PXE7300 In-Flight Entertainment system.

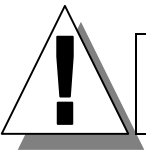
Operating controls consist of two rotary knobs with push-push switches, and four buttons.



Figure 3-1 Front Panel Controls

#### 3.2 Operating Controls

The single-disk player is designed for simple operation. The Disc player will begin to play automatically when a Disc is inserted (unless the disc is specially formatted as 7300 volume, see section 3.4). The disc will play through in order, and then stop at the end. If a disc is not inserted, the unit will be in the FM radio mode.



**NOTE:**

When a disc is inserted, the display will show "Reading . . ." for up to 20 seconds, depending on the media and amount of information contained.

**NOTE:**

The MP3 mechanism in the PXE7300 is more sensitive to scratches on the play side of the disc than traditional CD players. It is suggested to use CDs that have few to no scratches for optimum performance.

The PXE7300 system is turned on and off by pushing the volume (left hand) knob. The left knob is the volume control. Turning the knob clockwise will increase the volume.

##### 3.2.2 Stop/Eject Button (2)

The Stop/Eject button will stop the disc. Hold for 3 seconds to eject the disc.

In AM or FM Radio Mode, this button scans up the frequency band for a strong signal.

##### 3.2.3 Play/Pause Button (3)

Pressing the play/pause button momentarily will pause the player. Press for about one second to advance the track or select another random track. Press and hold the PLAY/PAUSE to for an INTRO SCAN that plays a few seconds of each track before advancing.

Momentarily pressing STOP/EJECT & PLAY/PAUSE buttons at the same time will cause the track to jump backward.

In AM or FM Radio Mode, this button scans down the frequency band for a strong signal.

### **3.2.4 The R/S Button (4)**

This selects random or sequence play in the disc mode.

### **3.2.5 The Data Knob (5)**

In the Disc mode (CD or MP3), the knob will advance (CW) or decrease (CCW) the track. Track number is displayed when the knob is in motion. Then it will display the track name and then begin to play.

In AM or FM radio mode, this knob can be used to tune the radio directly.

If the playing media is an MP3 format, the pushing the DATA knob will display the data (if stored and available) from the playing tracks in sequence when the knob is pushed.

- Song Name
- MP3 Actual File Name
- Album
- Artist

Depending on the total size of the information stored on the disc, the available data may be truncated in the following manner: Small number of files, Actual File Name, Larger number of files, Truncated File Name, Most files, Track Number.

If the SIRIUS Radio option is included, a long press will toggle between the channel number and the audio stream name.

### **3.2.6 The MODE Button (6)**

This button cycles through the operating modes, Disc, FM, AM, SR and AUX (if enabled).

## **3.3 Radio Reception**



The passive AM/FM antenna, part number 510-730-0001 (included) is optimized for FM radio performance. Therefore, when used for AM reception, the operator may only receive the most powerful 3 to 5 AM stations. In contrast to an ADF, where audio fidelity is not important, the PXE7300 requires higher signal levels to ensure fidelity.

For optimum performance, some installers may desire an external AM/FM antenna. PS Engineering recommends a Comant CI-222-L.

Another alternative is to connect the PXE7300 antenna input to an unused VOR port of the VHF NAV antenna splitter. Do NOT add another splitter.

## **3.4 Radio Preset Function**

The PXE7300 can save up to nine AM frequencies, nine, FM frequencies, and nine SIRIUS streams for future recall. Select the desired radio frequency.

To set press the "R/S" button (4). The next available slot will be displayed as "S#." (# being the available memory location). Within five seconds, select the desired channel using the DATA knob (if not already displayed). Press the R/S (4) again to save the selection. The display will flash, indicating a successful save.

You can select the "S" slot by pressing the Stop (up) and play (down) buttons.

To access the channel, press the DATA knob (5) the radio mode, and select the preset with the DATA knob or scan up (2) and down (3) buttons.

Action	Disc Result	Radio Result	SIRIUS Result
<b>▲ short press</b>	Stop	Frequency Scan Up	No Change
<b>▲ long press</b>	Eject (also in AUX)		
<b>▶ short press</b>	Pause	Frequency Scan Down	No Change
<b>▶ long press</b>	Select next track/file and keep playing or a random track if in the random mode		
<b>MODE press</b>	Change from FM to AM, to SR (if present), AUX to (if enabled) to DISC back to FM		
<b>R/S press</b>	Toggle into Random or Sequence play	Enter the preset "Set" mode	Enter the preset "Set" mode
<b>DATA knob CW</b>	Select next track and play	Increase radio frequency or preset channel	Increment audio Stream or preset channel
<b>DATA knob CCW</b>	Select previous track and keep playing	Decrease radio frequency or preset channel	Decrement Audio Stream or preset channel
<b>DATA knob Push</b>	Show data on file (if available)	Enter Pre-select Frequency Recall Mode	Enter Pre-select Frequency Recall Mode, OR, Display audio stream title if held longer.

**Table 1- PXE7300 Modes**

### **3.5 SIRIUS Module Operation**

The PSM7390 SIRIUS Satellite radio module is completely controlled by the PXE7300-SR unit. To activate, push the "Mode" button until SR and channel number, are displayed on the PXE7300. When the module is activated by subscription, and the antenna has a clear view of the sky, SIRIUS audio will be present in the entertainment system.

The SIRIUS audio stream can be selected with the "data" knob (5). Pressing the Data knob for more than 2 seconds will display the title of the audio channel.

### 3.5.1 SIRIUS SIGNAL DROP OUT:



NOTE: SIRIUS Satellite Radio uses ground-based transmitters in populated areas to ensure consistent road coverage. However, for airborne receivers, these ground-based signals may cancel satellite-transmitted signals, resulting in a dropped signal. You may experience interruptions in the airborne SIRIUS signal near large cities. This interruption will be variable, depending on AGL altitude, distance, number of ground-based transmitters and azimuth to the transmitters.

**PS Engineering, Inc. does not guarantee SIRIUS Satellite Radio coverage in all areas, or the suitability of the SIRIUS Satellite Radio for any particular geographical area.**

### 3.6 *Display Dimming (7)*

The display is automatically adjusted for ambient light conditions by a photocell. The backlighting is adjusted by the aircraft dimmer circuit.

## Section IV- Warranty and Service

### 4.1 Warranty

In order for the factory warranty to be valid, the installations in a certified aircraft must be accomplished by an FAA-certified avionics shop and authorized PS Engineering dealer. If the unit is being installed by a non-certified individual in an experimental aircraft, a factory-made harness must be used for the warranty to be valid.

PS Engineering, Inc. warrants this product to be free from defect in material and workmanship for a period of one (1) year from the date of installation as recorded in aircraft logbook and/or on FAA Form 337. During the **twelve (12) months**, PS Engineering, Inc., at its option, will send a replacement unit at our expense if the unit should be determined to be defective after consultation with a factory technician.

All transportation charges for returning the defective units are the responsibility of the purchaser. All domestic transportation charges for returning the exchange or repaired unit to the purchaser will be borne by PS Engineering, Inc. The risk of loss or damage to the product is borne by the party making the shipment, unless the purchaser requests a specific method of shipment. In this case, the purchaser assumes the risk of loss.

This warranty is not transferable. Any implied warranties expire at the expiration date of this warranty. PS Engineering SHALL NOT BE LIABLE FOR INCIDENTAL OR CONSEQUENTIAL DAMAGES. This warranty does not cover a defect that has resulted from improper handling, storage or preservation, or unreasonable use or maintenance as determined by us. This warranty is void if there is any attempt to disassemble this product without factory authorization. This warranty gives you specific legal rights, and you may also have other rights, which may vary from state to state. Some states do not allow the exclusion of limitation of incidental or consequential damages, so the above limitation or exclusions may not apply to you.

All items repaired or replaced under this warranty are warranted for the remainder of the original warranty period. PS Engineering, Inc. reserves the rights to make modifications or improvements to the product without obligation to perform like modifications or improvements to previously manufactured products.

### 4.2 Factory Service

The unit is covered by a one-year limited warranty. See warranty information. Call PS Engineering, Inc. at (865) 988-9800 before you return the unit. This will allow the service technician to provide any other suggestions for identifying the problem and recommend possible solutions.

After discussing the problem with the technician and you obtain a Return Authorization Number, ship product to:

PS Engineering, Inc.  
Attn: Service Department  
9800 Martel Rd  
Lenoir City, TN 37772  
(865) 988-9800 FAX (865) 988-6619

Email: [support@ps-engineering.com](mailto:support@ps-engineering.com)

**NOTE: PS Engineering will not be responsible for any units shipped in the U. S. Mail.**

**Units received without either a Return Authorization or a contact telephone number will be refused and returned to the sender.**

## Appendix A – MP3 Creation

### 5.1 Creating MP3s from an Audio CD

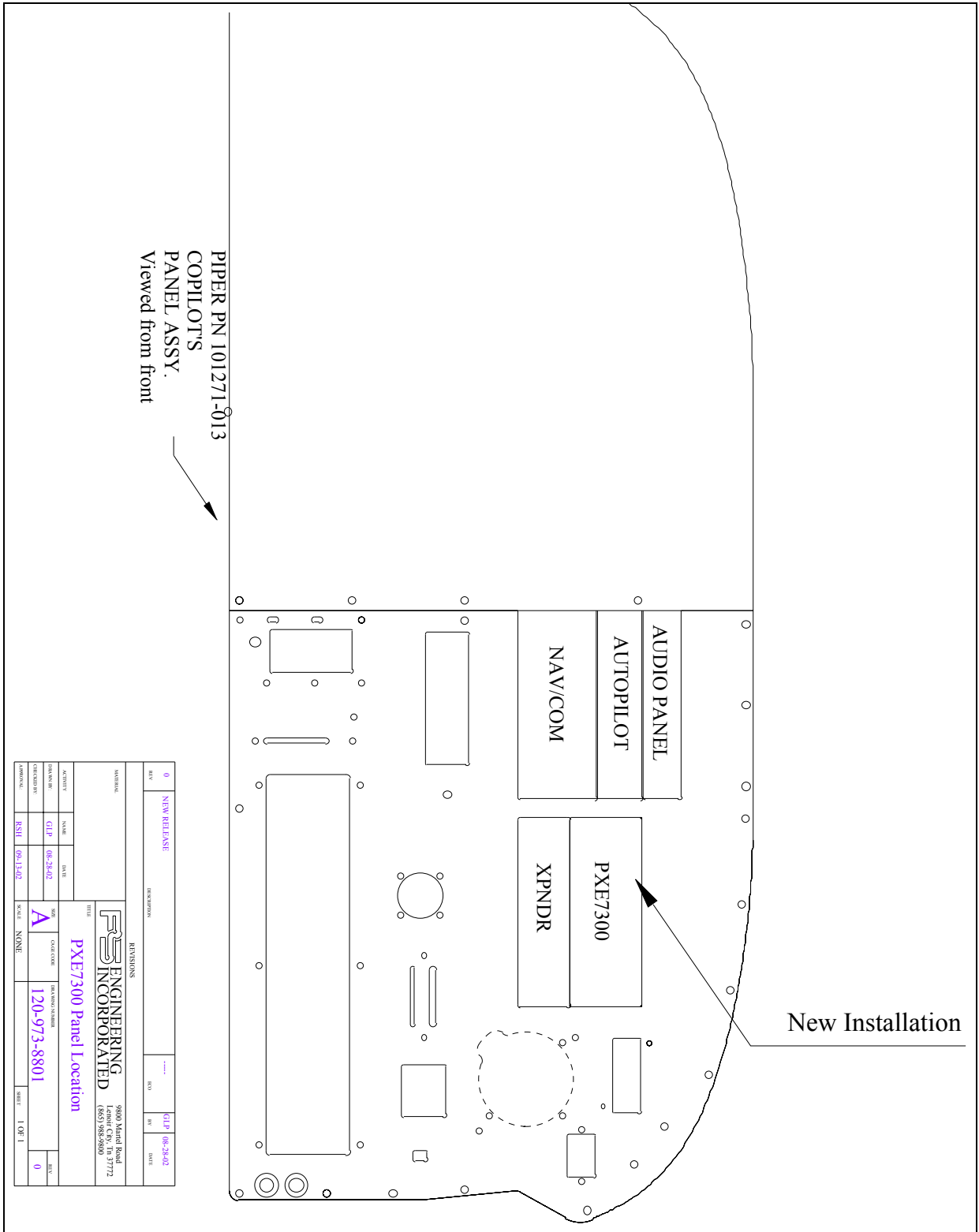
1. Start MusicMatch JukeBox. ([www.musicmatch.com](http://www.musicmatch.com)) Press the recorder button, which is the small red dot located in the top right corner. This will open the recorder window located at the bottom of the screen.
2. Insert an audio CD into the CD drive. MusicMatch will automatically read the disc and display the contents in the recorder window. Press the REFRESH button to check the Internet database for CD information, such as artist, song title, or album. If this information is available, it will automatically be updated in the file.

**NOTE:**

**For best results, burn the disc at the disc manufacturer's recommendation speed or SLOWER. Burning faster may result in skipping problems with some disc media.**

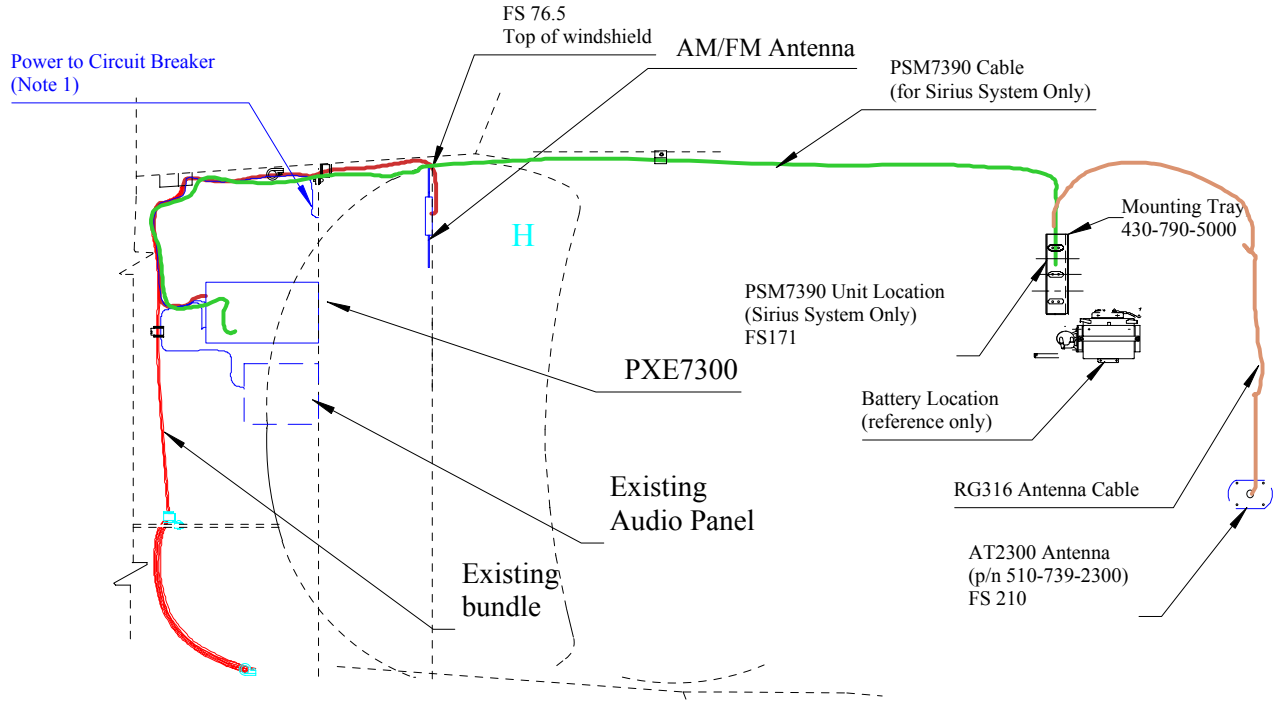
3. Select Options->Recorder->Format and select either MP3 or MP3PRO format. You may also set the MP3 file quality under the Options->Recorder->Quality menu.
4. Select the tracks to be copied to MusicMatch by checking the box next to the desired track. Press the record button in the lower left corner when complete
5. MusicMatch will then convert the files from the audio CD to MP3 and display them in the Music Library box located in the middle of the screen
6. To edit the MP3 information, select a file in the Music Library and press the TAG button in the top right corner of the Music Library box. This will display the MP3 tagged information screen. Select the General tab to show the information that can be modified for the PXE7300.
7. The PXE7300 can display song name, artist, album, and filename. This corresponds to the Track title, Artist, Album, and Track Filename fields shown on the screen. Each of these fields can be modified to the user's preference. Note: The PXE7300 is limited to displaying up to 22 characters in each of these fields. Click on the appropriate field to modify the track title, artist, or album. To modify the filename, select the Rename Files button in the lower left corner. Click on the field labeled New File Name and press OK to change the file name. Press the Apply and OK buttons to update the information

**Appendix B – Installation Drawings**

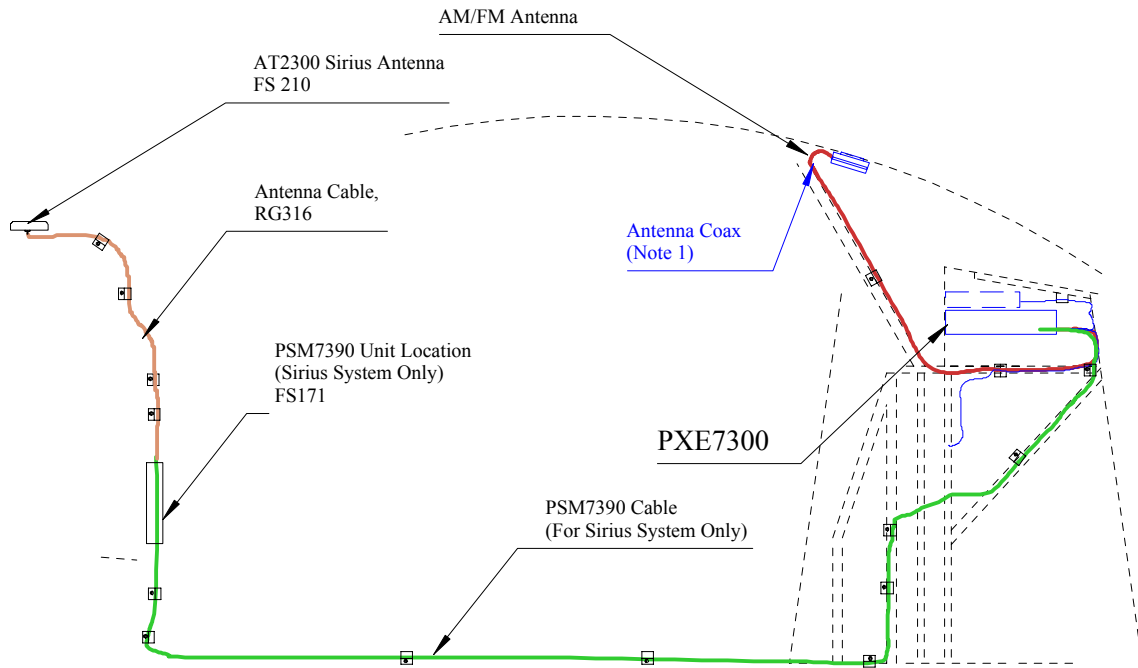


**Figure 6-1 Panel Location Drawing (Typical) 120-973-8801**

**PS Engineering**  
**PXE7300 SR SIRIUS Satellite Radio IFE System**  
**Installation and Operator's Manual**



**Plan View**



**Elevation View**

**Figure 6-2 PXE7300 Installation Diagram (Typical) 120-974-2488**

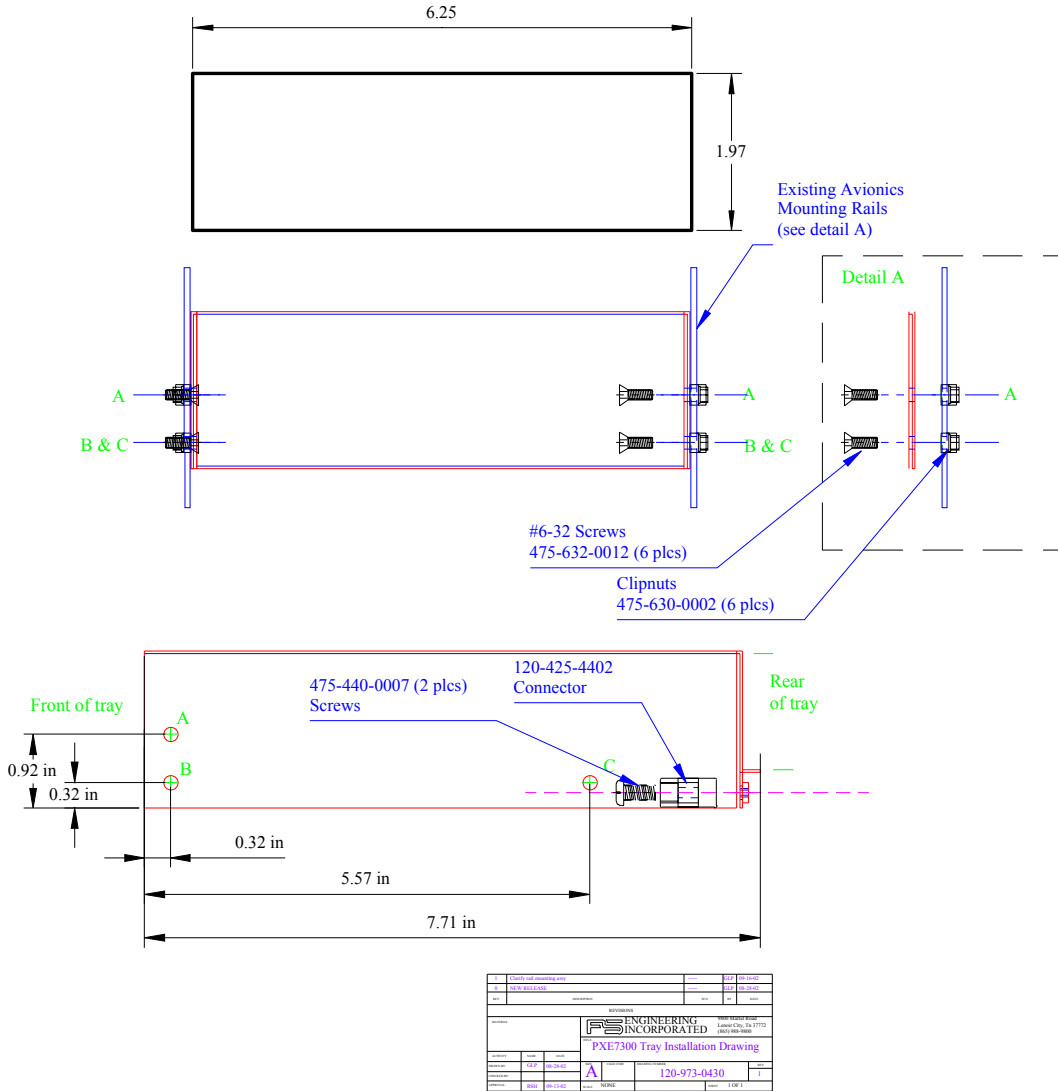
**NOTES:**

Install wire bundle and cable clamps as required IAW AC43.13-1B: Section 8, WIRING INSTALLATION INSPECTION REQUIREMENTS Section 9, ENVIRONMENTAL PROTECTION AND INSPECTION Section 11, CLAMPING

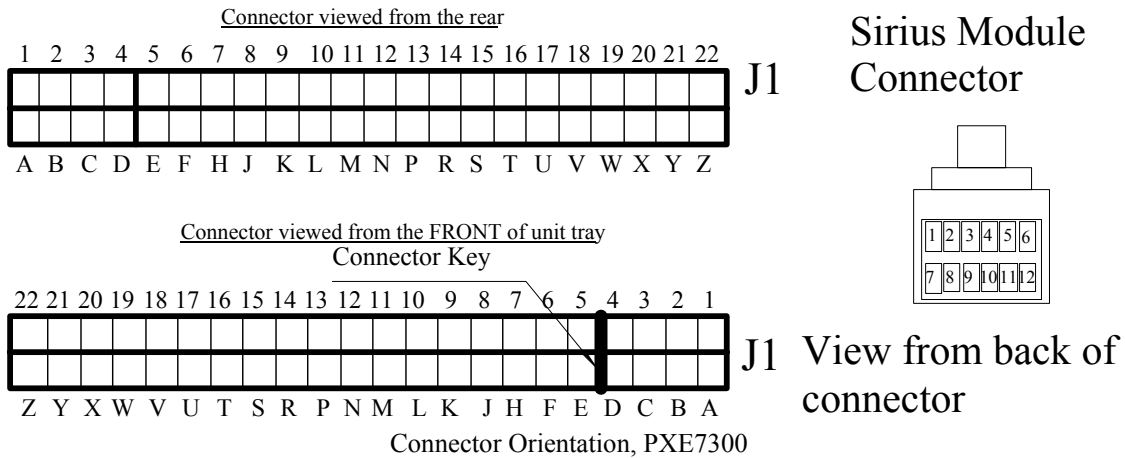
Clean antenna area with solution approved by aircraft manufacturer. Use 3M Self-adhesive tape (supplied ) to secure antenna to windshield. Verify that vision is not obscured from any crew position.



**PS Engineering**  
**PXE7300 SR SIRIUS Satellite Radio IFE System**  
**Installation and Operator's Manual**



**Figure 6-3 Tray Installation Drawing, 002-973-0430**



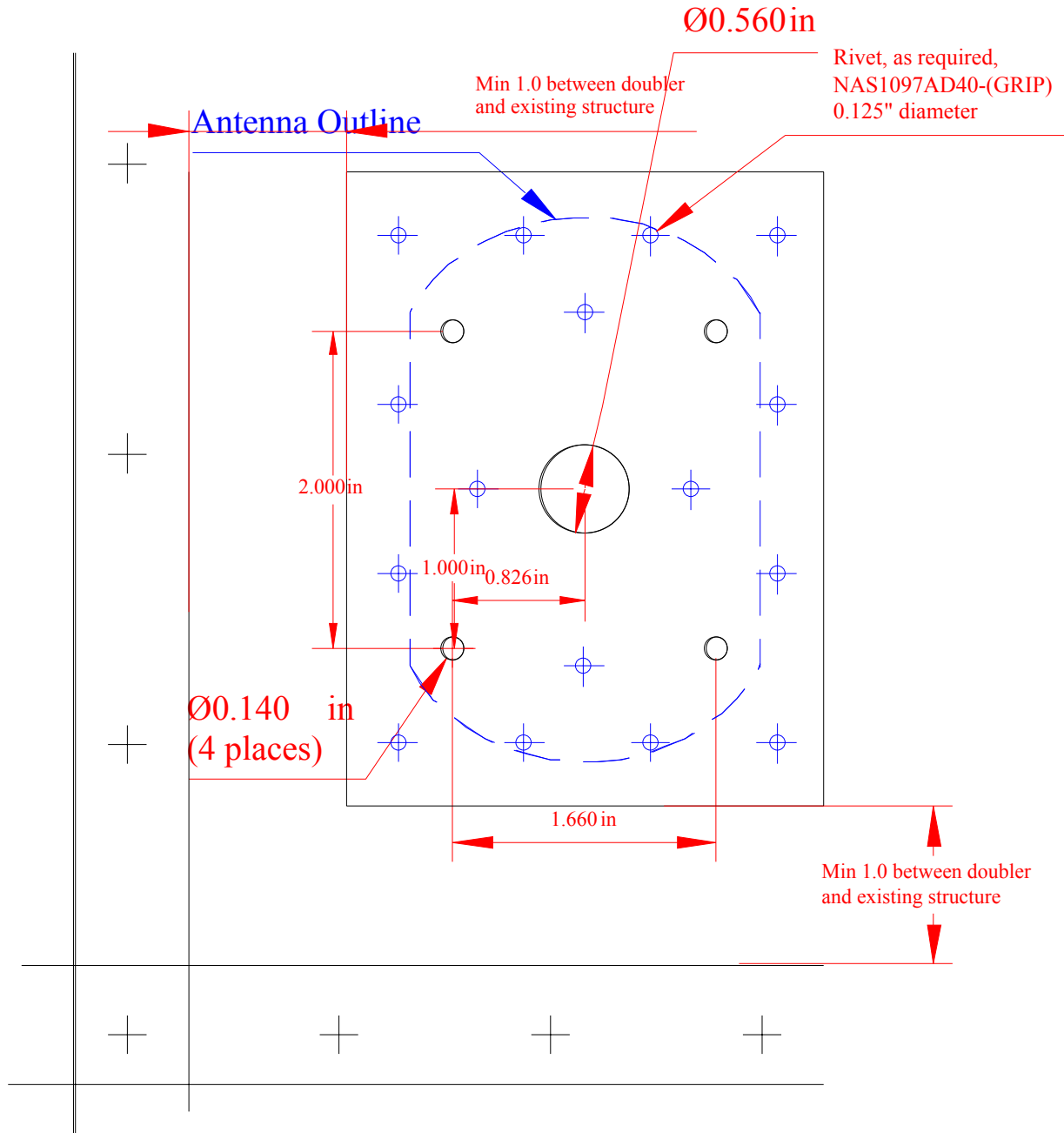


Figure 6-4 - Satellite Radio Antenna Mounting NOT TO SCALE (120-230-2488)

Antenna Installation Notes:

Antenna must be installed on TOP of aircraft, per this installation manual

Edge of doubler to be minimum of 1.0-inch from existing structure.

All dimensions  $\pm 0.030$ "

Must use a doubler plate, p/n 430-230-2488, or equiv.

Maximum skin thickness 0.040"

Secure doubler with NAS1097AD-4-(GRIP) rivet.

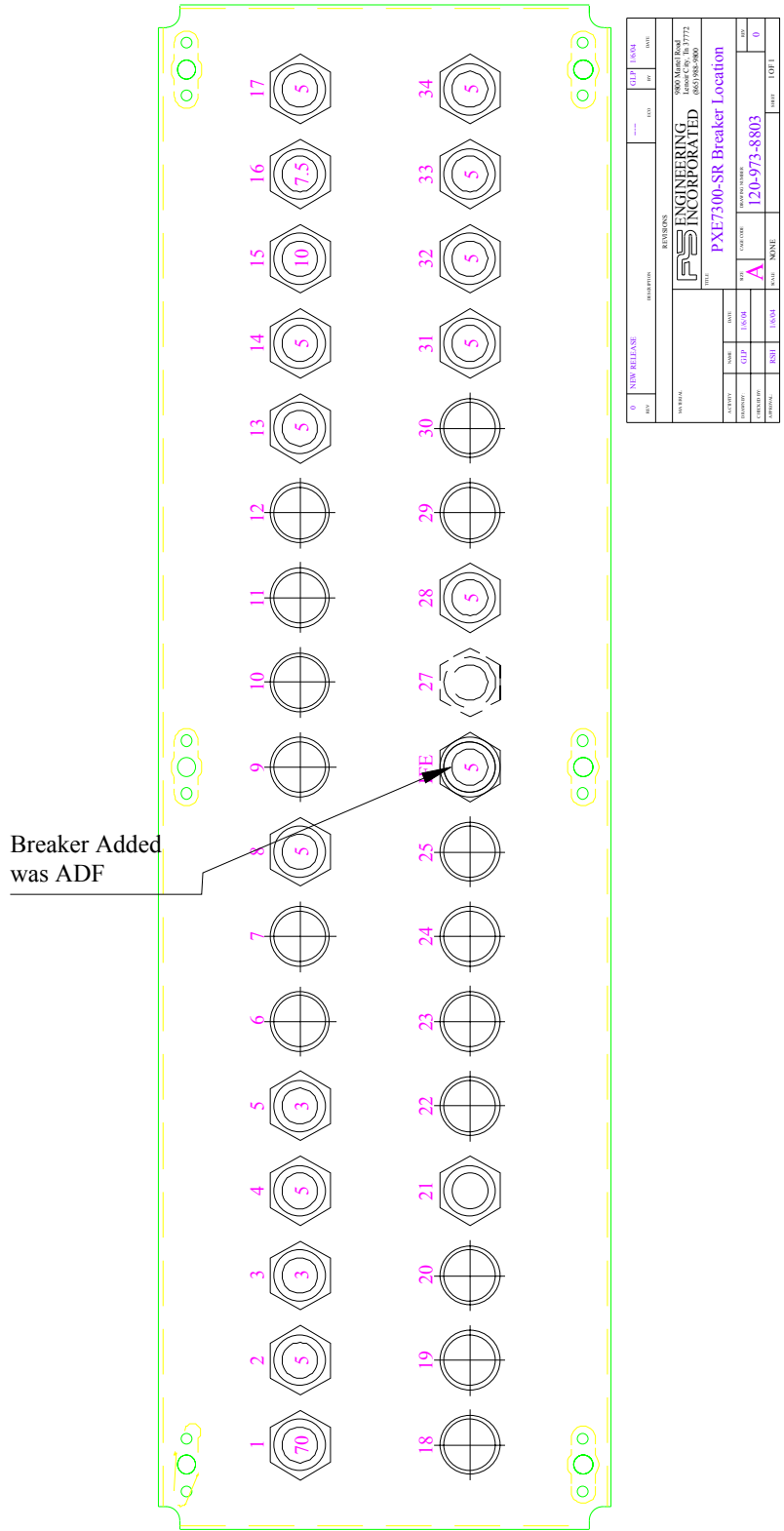
Dimple Fastener locations for skins less than 0.028" Install fasteners i.a.w. AC43.13-1B.

Secure antenna with AN520 ( or equiv.) SS PPHD screw,  
MS21042-06 ( or equiv.) nut and AN960 ( or equiv.) washer.

Secure antenna with AN520 ( or equiv.) SS PPHD screw, MS21042-06 ( or equiv.) nut and AN960 ( or equiv.) washer.

Antenna wt. 0.25 lb.

**PS Engineering**  
**PXE7300 SR SIRIUS Satellite Radio IFE System**  
**Installation and Operator's Manual**

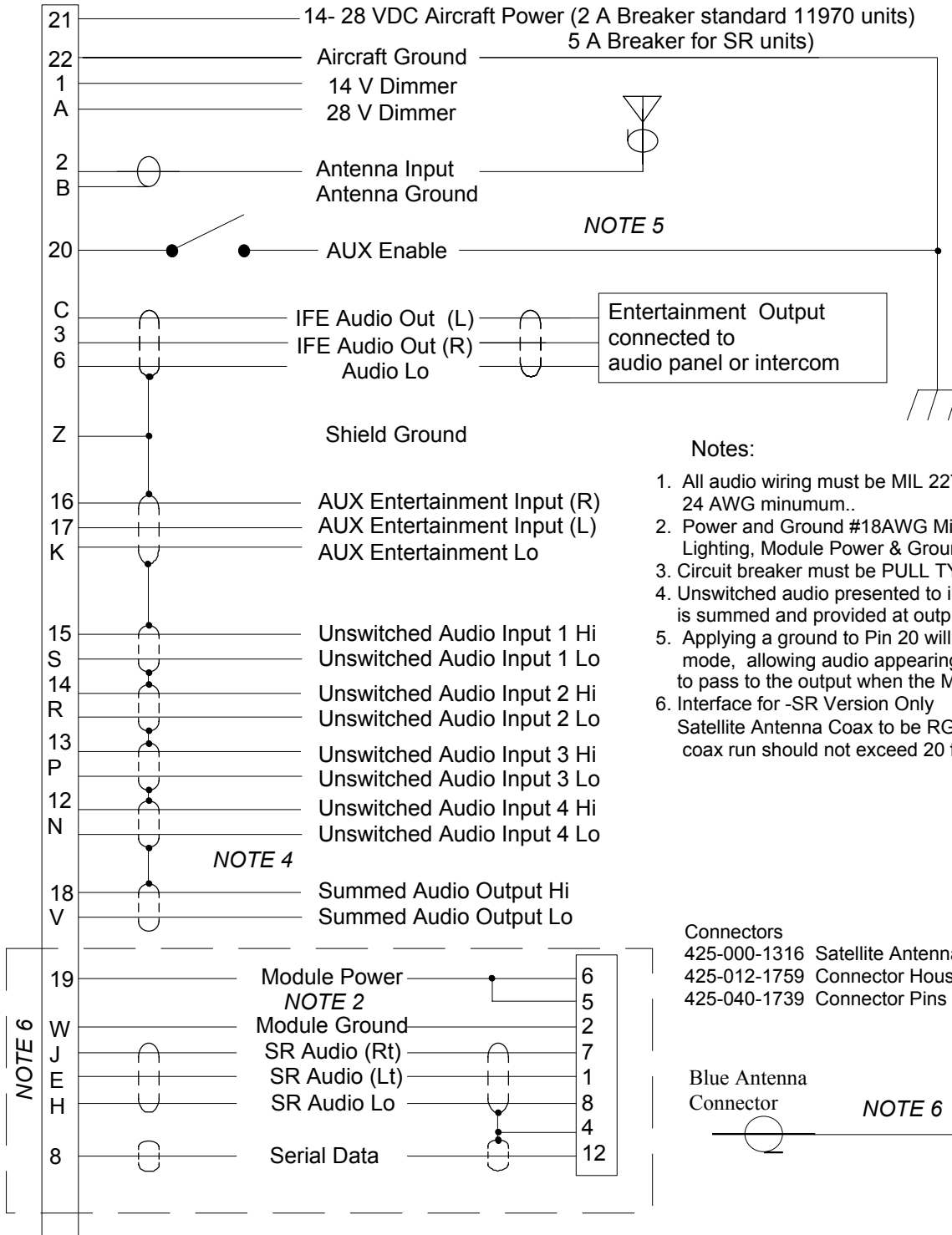


**Figure 6-5 Circuit breaker installation drawing 120-973-8802 (typical)**

## Appendix C Connector Interconnect

### PXE7300 Connector

**NOTE 3**



## Appendix D- STC information and instructions for continuing airworthiness

### 8.1 Instructions for FAA Form 337, PXE7300-SR

STC SA02795AT applies, with an FAA-Approved Model List (AML) document 002-793-1080, to specific aircraft makes and models. Consult [www.ps-engineering.com/PXE7300.shtml](http://www.ps-engineering.com/PXE7300.shtml) for this complete list.

One method of airworthiness approval in other aircraft is through an FAA Form 337, *Major Repair and Alteration (Airframe, Powerplant, Propeller, or Appliance)* In the case of the PXE7300, you may use the following text as a guide.

This unit is installed in accordance with FAA-STC SA02795AT, which specifically references the installation manual, including Master Drawing List, 002-739-2001 shown in Section 9.3.

Installed IFE System, PS Engineering PXE7300, part number 11970-SR in ( location ) at station \_\_\_\_\_. and PSM7390, part number 010-731-1030 in ( location ) at station \_\_\_\_\_. Also Installed AT2300 SIRIUS Antenna, Part Number 510-739-2300 at ) at station \_\_\_\_\_, using doubler 120-203-1203. , Installed per AC43.13-2, Chapter 2, paragraph 23 (Instrument Panel Mounting), Chapter 2, paragraph 24 (Other Mounting Locations), and Chapter 3 (Antenna Installations). Installed per PS Engineering *Installation Operators Manual* p/n 200-739-0001, revision ( ), dated ( ).

Interface to existing aircraft radios in accordance with installation manual and in compliance with practices listed in AC43.13-2, Chapter 2. All wires are Mil-Spec 22759 or 27500. Connection to aircraft dimmer bus is \_\_\_\_\_. Power is supplied to the unit through a \_\_\_A circuit breaker (type and part number), and total electrical load does not exceed \_\_\_% of the electrical system capacity with the PXE7300 added.

Aircraft equipment list, weights and balance amended. Compass compensation checked. A copy of the operation instructions, contained in PS Engineering document 200-730-( ), revision ( ), dated ( ), is placed in the aircraft records. All work accomplished listed on Work Order\_\_\_\_\_.

### 8.2 Instructions for Continuing Airworthiness, PXE7300 System

Sample ICA Checklist for PS Engineering PXE7300-SR:

Section	Item	Information
1	Introduction	Installation of In-Flight Entertainment system.
2	Description	Installation as described in manufacturer's installation manual referenced on FAA Form 337, including interface with other avionics audio as required.
3	Controls	See installation and operator's guide referenced on FAA Form 337.
4	Servicing	None Required
5	Maintenance Instructions	On Condition, no special instructions
6	Troubleshooting	In the event of a unit problem, place the unit into "off," "fail-safe" and/or "emergency" mode. This allows pilot communications using aircraft radios. Follow checkout instructions in the installation manual referenced on the FAA Form 337. For a specific unit fault, contact the manufacturer at (865) 988-9800 for special instructions.
7	Removal and replacement information	<u>Removal:</u> Using a 3/32" Allen-head wrench, carefully unscrew the locking screw located in the center of the unit. While turning the wrench CCW, gently pull on the EDGES of the bezel until the unit is free from the mounting tray. <u>Installation:</u> Engage the locking screw at the back. Turn the locking screw CW, while applying slight pressure to the edges of the bezel. Do not over tighten!
8	Diagrams	Not applicable
9	Special Inspection Requirements	Not Applicable
10	Protective Treatments	Not Applicable
11	Structural Data	Not Applicable
12	Special Tools	None
13	Not Applicable	Not Applicable
14	Recommended Overhaul Periods	None
15	Airworthiness Limitations	Not Applicable
16	Revision	To be determined by installer

### 8.3 Master Drawing List

The following drawings are contained on the FAA-Approved Master Drawing List:

<b>PXE7300 Master Drawing List</b>		<b>002-739-2001 R1</b>		
<b>Drawing Title</b>	<b>In this manual</b>	<b>Part Number</b>	<b>Revision</b>	<b>Date</b>
Installation Manual	X	200-739-0001	1	12-Jan-04
Installation Wiring	X	120-973-0000	7	6-Jan-04
Tray Installation Drawing	X	120-973-0430	1	16-Sep-02
PXE7300 Installation Diagram w/ SIRIUS Module	X	120-973-2488	2	24-Nov-03
PXE7300 Panel Location	X	120-973-8801	New	28-Aug-02
PXE7300 Breaker Location	X	120-973-8803	New	6-Jan-04
Users Guide for SIRIUS Radio		202-739-0001	New	Dec-03
PSM7390 Module Installation Drawing	X	120-979-0430	2	16-Jan-04
PSM7390 Module Rack Part Drawing		430-739-5000	1	7-Jan-04
PSM7390 Module Rack Shelf Install.	X	430-739-2488	New	23-Dec-03
AT2300 SIRIUS Antenna		510-739-2300	3	29-Dec-03
AT2300 SIRIUS Antenna Mounting	X	120-230-1203	1	26-Jan-04

### 8.4 Use of Approved Model List

STC SA02595AT can be used as a basis for approval in those airplanes listed in the Approved Model List (002-739-1080) provided the generic installation manual, Document Number 200-739-0001 or later approved revision, is followed.

Advisory Circulars AC43.13-1B Acceptable Methods, Techniques, and Practices - Aircraft Inspection and Repair, and 43.13-2A - Acceptable Methods, Techniques, And Practices - Aircraft Alterations are to be used to resolve any issues not specifically addressed by the Installation Manual. Instructions for Continuing Airworthiness (ICA) are provided in the supplied data.

United States of America  
Department of Transportation -- Federal Aviation Administration  
**Supplemental Type Certificate**

*Number* SA02795AT

*This certificate issued to* PS Engineering Incorporated  
9800 Martel Road  
Lenoir City, TN 37772

*certifies that the change in the type design for the following product with the limitations and conditions therefor as specified hereon meets the airworthiness requirements of Part (See AML) of the (See AML) Regulations.*

*Original Product - Type Certificate Number :* \* See attached  
*Make :* FAA Approved Model (AML)  
*Model :* Document 002-793-1080 for a list of Approved  
*Description of Type Design Change:* Airplane Models

Installation of a PXE7300SR, In-Flight Entertainment System in accordance with Master Drawing List 002-739-2001, Revision 1, dated January 27, 2004, or later FAA Approved Revision.

*Limitations and Conditions :*

This approval should not be extended to other aircraft of this model on which other previously approved modifications are incorporated unless it is determined by the installer that the interrelationship between this change and any of those other previously approved modifications will produce no adverse affect upon the airworthiness of that airplane. If the holder agrees to permit another person to use this certificate to alter the product, the holder shall give the other person written evidence of that permission.

*This certificate and the supporting data which is the basis for approval shall remain in effect until surrendered, suspended, revoked or a termination date is otherwise established by the Administrator of the Federal Aviation Administration.*

*Date of application :* January 06, 2004

*Date reissued :*

*Date of issuance :* February 12, 2004

*Date amended :*



*By direction of the Administrator*

*Melvin D. Taylor*

(Signature)

M Melvin D. Taylor, Manager,  
Atlanta Aircraft Certification Office

(Title)

Any alteration of this certificate is punishable by a fine of not exceeding \$1,000, or imprisonment not exceeding 3 years, or both.

## Appendix E RTCA DO160D/EUROCAE ED-14D Environmental Qualification Form

Part Number: 11970

Manufacturer: PS Engineering Incorporated 9800 Martel Road Lenoir City TN 37772

Conditions	Section	Conducted Tests
Temperature and Altitude	4.0	Equipment tested to CAT B1
Low Temperature	4.5.1	-55° C Storage, -20°C Low Operating
High Temperature	4.5.2	+85°C Storage, +70°C High Operating
In-flight Loss of Cooling	4.5.4	Not Applicable, no cooling required
Altitude	4.6.1	25,000' unpressurized
Decompression	4.6.2	Not Applicable
Overpressure	4.6.3	Not Applicable
Temperature variation	5.2	Equipment tested to Category C
Humidity	6.0	Equipment tested to Category A
Shock	7.0	Equipment tested to Operational test only
Operational	7.2	Equipment tested Category B
Crash Safety	7.3	
Vibration	8.0	Equipment tested to Category S
Explosion	9.0	Category X, not tested
Waterproofness	10.0	Category X, not tested
Fluids Susceptibility	11.0	Category X, not tested
Sand and Dust	12.0	Category X, not tested
Fungus	13.0	Category X, not tested
Salt Spray	14.0	Category X, not tested
Magnetic Effect	15.0	Equipment tested to Category Z
Power input	16.0	Equipment tested to Category B
Voltage Spike	17.0	Equipment tested to Category B
Audio Frequency Susceptibility	18.0	Equipment tested to Category B
Induced Frequency Susceptibility	19.0	Equipment tested to Category A
Radio Frequency Susceptibility	20.0	Equipment tested to Category U
Radio Frequency Emission	21.0	Equipment tested to Category H
Lightning Induced Transient Susceptibility	22.0	Category X not tested
Lightning Direct Effects	23.0	Category X not tested
Icing	24.0	Category X, not tested
Electrostatic Discharge	25.0	Category X, not tested
Other Tests		Passed FM Emissions testing in accordance with CFR 47, Part 15.109.



**PS Engineering**  
PXE7300 SR SIRIUS Satellite Radio IFE System  
Installation and Operator's Manual

Nomenclature: Satellite Radio Receiver Module, PSM7390

Part Number: 010-731-1030

Manufacturer: PS Engineering Incorporated 9800 Martel Road Lenoir City TN 37772

<b>Conditions</b>	<b>Section</b>	<b>Conducted Tests</b>
Temperature and Altitude	4.0	Equipment tested to CAT B1
Low Temperature	4.5.1	-55° C Storage, -20°C Low Operating
High Temperature	4.5.2	+85°C Storage, +70°C High Operating
In-flight Loss of Cooling	4.5.4	Not Applicable, no cooling required
Altitude	4.6.1	50,000' unpressurized
Decompression	4.6.2	Not Applicable
Overpressure	4.6.3	Not Applicable
Temperature variation	5.2	Equipment tested to Category C
Humidity	6.0	Equipment tested to Category A
Shock	7.0	Equipment tested to Operational test only
Operational	7.2	Equipment tested Category B
Crash Safety	7.3	
Vibration	8.0	Equipment tested to Category S
Explosion	9.0	Category X, not tested
Waterproofness	10.0	Category X, not tested
Fluids Susceptibility	11.0	Category X, not tested
Sand and Dust	12.0	Category X, not tested
Fungus	13.0	Category X, not tested
Salt Spray	14.0	Category X, not tested
Magnetic Effect	15.0	Equipment tested to Category Z
Power input	16.0	Equipment tested to Category B
Voltage Spike	17.0	Equipment tested to Category B
Audio Frequency Susceptibility	18.0	Equipment tested to Category B
Induced Frequency Susceptibility	19.0	Equipment tested to Category A
Radio Frequency Susceptibility	20.0	Equipment tested to Category U
Radio Frequency Emission	21.0	Equipment tested to Category H
Lightning Induced Transient Susceptibility	22.0	Category X not tested
Lightning Direct Effects	23.0	Category X not tested
Icing	24.0	Category X, not tested
Electrostatic Discharge	25.0	Category X, not tested