

PS ENGINEERING[®] INCORPORATED

Sound Quality. Sound Engineering.

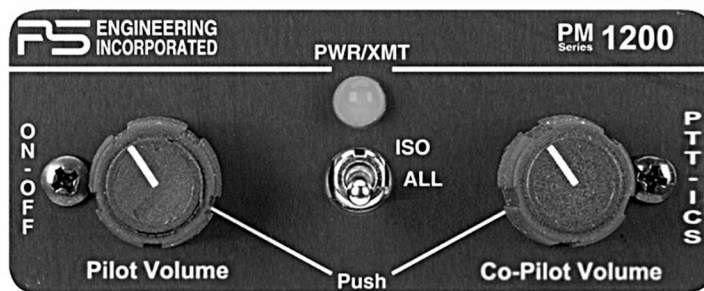

PM1200 **Panel Mounted Intercom with** **IntelliVOX[®]** **for High Noise Application** Part No. 11960

Includes 11961 & 11960-Exp

Operator's and Installation Manual

PS ENGINEERING, INCORPORATED

9800 Martel Road

Lenoir City, TN 37772

Phone (865) 988-9800 FAX (865) 988-6619

www.ps-engineering.com

U. S. Patent 6,493,450

NOTICE: Warranty is not valid unless this product is installed by an Authorized PS Engineering dealer.

Document Number 200-196-0104

Rev 13, April 2020

PS Engineering, Inc. 2020©

Copyright Notice

Any reproduction or retransmittal of this publication, or any portion thereof, without the expressed written permission of PS Engineering, Inc. is strictly prohibited. For further information contact the Publications Manager at PS Engineering, Inc., 9800 Martel Road, Lenoir City, TN 37772. Phone (865) 988-9800

Section 1 General Information

1.1 Introduction

The **PM1200** is a panel mounted, 2-place (expandable with IntelliPAX p/n 11616R) monaural intercom system (ICS) designed specifically for high-noise aircraft environments. Please read this manual completely before installation to minimize the risk of damage to the unit and to become familiar with all the features.

1.2 Scope

This manual contains installation and operational instructions for the following PS Engineering units:

Part Number	Description
-------------	-------------

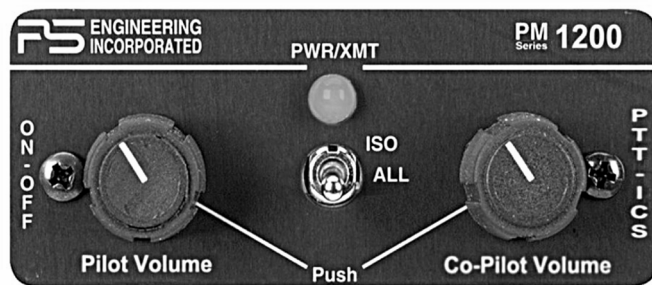

11960	Push to talk intercom for use in noisy cockpits
11961	Same as above but remote (blind) mounting
11960-Exp	Same as above, but with expansion capability

1.3 Description

The **PM1200** is a 2-place (unless expanded), panel-mounted intercom with PS Engineering's proprietary IntelliVOX® intercom protocol. The audio has been further enhanced with extra audio filtering for the microphones, and added headphone audio power.

The **PM1200** is backward compatible with **PM1000II** units, P/N 11902, 11909 and 11922— contact factory for details. *However, the **PM1000-series** MUST be wired correctly per the manual, particularly the pilot radio PTT.*

The unit can be used as either voice-activated, or push to talk intercommunications, by simply pushing a front panel switch.

The **PM1200** has an automatic fail-safe interconnect to the aircraft radio. If power to the intercom is disrupted, an internal relay will connect the pilot's headset to the aircraft radio. This allows continuous radio communications. Note: *The copilot will no longer hear aircraft radio when power is removed.*

An entertainment input is provided, allowing the users to listen to music during flight. During intercom or aircraft radio traffic, this music is automatically muted to allow communications without distraction. When the activity ceases, the Soft Mute™ circuit gradually returns the music to the original volume.

Both pilot and copilot have transmit capabilities over the radio. The **PM1200** allows only the person who presses their radio PTT to be heard over the aircraft radio. If both pilot and copilot press the PTT at the same time, the pilot

will have priority and override the copilot.

1.4 Approval Basis *None*

The **PM1200**, 11960, 11960-EXP, or 11961, is NOT FAA Approved. It is the installers responsibility to determine suitability for installation.

1.5 Specifications

Input power:	13.8 - 27.5 Volts DC
Current Drain:	< 250 mA (Externally fused at 1 Amp)
Output	120 mW into 150Ω @ 27.5 VDC 70 mW @ 13.75 VDC
Headphone Impedance:	150-1000 ohms typical
Aircraft Radio Impedance:	500- 1000 Ω typical
3 dB Music Frequency Response:	200 Hz to 15 kHz
Unit weight:	12 Ounces (0.342 kg)
Dimensions:	1.25" H x 3.00" W x 5.80" D (3.2 x 7.6 x 14.7 cm)
Temperature	-20°C to +55°C
Altitude	50,000 ft.

1.6 Equipment required but not supplied

- Headphones, 150-300Ω monaural, up to two as required
- Microphones, up to two, as required
- Crimping Tool, AMP 601966-1 , and Positioner, 601966-5 (or equiv.)
- Appropriately constructed interconnect wiring
- Circuit Protection, 1 Amp.
- Radio PTT switches (1-pilot, 1-copilot)
- Intercom PTT switches (if desired) 2 ea.

Section 2 Installation

2.1 General Information

The **PM1200** comes with all necessary mechanical hardware for installation. Installation of the **PM1200**, using the appropriate wiring and hardware, does not require special tools or knowledge other than described in FAA Advisory Circular 43.13-2B. Installers should be qualified in accordance with 14 CFR 65.81(b).

It is the installer's responsibility to determine the approval basis for this installation. An FAA Form 337, or other field approval may be required in a certified aircraft. A custom-made wiring harness is available from PS Engineering, shipped within 5-business days of order. Visit www.ps-engineering.com for more information.

2.2 IntelliVox®

The **PM1200** has both automatic VOX (IntelliVox® and PTT-ICS. For open cockpit aircraft and the majority of warbirds, using the **PM1200** in PTT-ICS (Push-To-Talk Intercom Mode) is required.

Turning either IntelliVox® or PTT-ICS function on and off you simply depress the Copilot Volume control knob. In one mode it will work with the Voice Operated Relay (VOX) automatically. Pressing the knob again will place the intercom into the PIT-ICS mode.

While in IntelliVox® mode, there must be some background noise so that the circuits that makes the automatic VOX work knows what noise is so then it can determine when a voice is present.

PM1200 Standard and Expansion (11960 & 11960-Exp) Installation Kit P/N 250-120-0100		
Part Number	Description	Quantity
350-990-0015	Foam Mic Muff	2
350-9909-0001	Leather Mic cover	2
475-442-0002	#4-40 Machine screws, black	2
625-003-0001	Soft Touch knobs	2
425-025-0009	25 pin Sub-d connector shell	1
625-025-0001	Connector hood	1
425-020-5089	Crimp Pins (Male)	25
575-120-0001	Reversible aluminum face plate	1
250-000-0002	2-place jack kit	1
200-196-00XX	Operator's and Installation Manual	1
122-102-0001	Drill Template	1
475-002-0002	Thumbscrews	2

PM1200 Remote (11961) Installation Kit P/N 250-120-0200		
Part Number	Description	Quantity
350-990-0015	Foam Mic Muff	2
350-9909-0001	Leather Mic cover	2
425-025-0009	25 pin Sub-d connector shell	1
625-025-0001	Connector hood	1
425-0205089	Crimp Pins (Male)	25
250-000-0002	2-place jack kit	1
200-196-00XX	Operator's and Installation Manual	1
675-120-0103	Pilot volume pot w/Switch 1/4" shaft	1
675-020-0103	Copilot volume pot 1/4" shaft	1
731-001-0001	Switch, SPDT On-On	2
625-020-0005	Knob, Black 1/2" shaft	2
475-002-0002	Thumbscrews	2

2.3 Equipment installation procedures

- Using the template, drill six holes in the instrument panel in a location convenient to the pilot position(s). The intercom can be mounted horizontally or vertically with supplied face plate.
- Insert the **PM1200** from behind the instrument panel, aligning the holes for the knobs, LED, and switch.

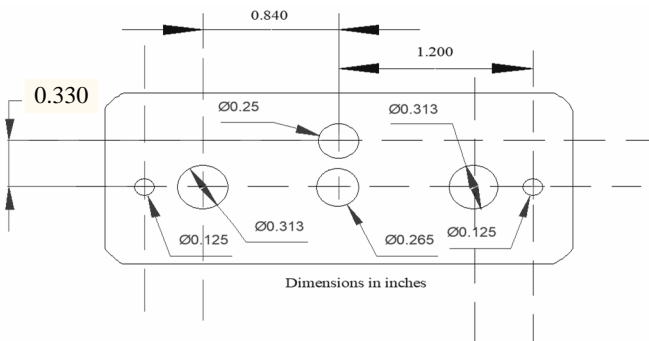

PM1200 Hole spacing (Not to scale)

3. Place the aluminum face-plate over the knob shafts and secure, using the two # 4-40 round head screws provided.

4. Install the knobs over the volume and squelch control shafts (except in the case of the 11961).

NOTE: See Page 9 for PM1200 Remote (11961R) installation diagram

2.3 Cable harness wiring

To complete the installation, a wire harness must be made as shown in the appropriate diagram.

PS Engineering can make a custom-tailored wiring harness for the installer. All harnesses use Mil-spec quality components with professional techniques, and are fully tested before shipment. Contact PS Engineering (865-988-9800) for more information.

If the aircraft already has pilot and copilot headset jacks installed, you may re-use them. Remove and discard all wires from the copilot headset jacks. You may use the existing pilot headset jacks as the Auxiliary Aircraft Radio Headset Jacks, but they should be moved to a new location to avoid confusion with the pilot's headphone jacks. In the event the intercom has to be removed for any reason, these jacks provide access to the aircraft radio system.

To connect intercom into the aircraft audio system, parallel the appropriate set of cables from the intercom to the Auxiliary Aircraft Radio Headset Jacks. Finally, install new headset jacks into the aircraft and connect them directly to the appropriate pins of the **PM1200**. See the wiring diagram for all details of the wire harness interconnects.

2.3.1 Electrical Noise Issues

WARNING: You must use separate shielded cables for the microphone and headphone jacks. Combining these two wires WILL cause loud oscillations and degrade the intercom function. The oscillation is caused by the cross-coupling between the large headphone signal and the small microphone signal. The resulting feedback is a high-pitched squeal that varies with the volume controls.

Due to the variety of the radio equipment found in today's general aviation aircraft, there is the potential of both radiated and conducted noise interference. The **PM1200** has a specially designed power supply to reduce conducted electrical noise on the power bus of the aircraft by at least 50dB. Although this is a very large amount of attenuation, it does not eliminate all noise when the amount is excessive. There must be at least 12 Volts DC present at the **PM1200** for the power supply to work within its designed regulation. Otherwise, it will not be able to attenuate noise properly.

Shielding can protect the system from radiated noise (rotating beacon, electric gyros, switching power supplies, etc.). However, installation combinations can occur where minor interference is possible. The **PM1200** was designed in an interference -protected chassis and has internal filter capacitors on all input lines.

Ground loop noise occurs when there are two different return paths for the same signal, such as airframe and ground return wire. Large cyclic loads such as strobes, inverters, etc., can inject audible signals onto the airframe return path. Follow the wiring diagram very carefully to help insure a minimum of ground loop potential. Radiated

signals can be a factor when low level mic signals are bundled with current carrying power wires. Keep these cables separated.

Insulating washers are required on all mic and headphone jacks to isolate them from aircraft ground. The use of a conductor instead of a shield for ground return eliminates these ground loop paths.

2.3.2 Power Requirements

The **PM1200** was designed to work with either 12 or 28 volt DC negative ground systems. The **PM1200** must be externally protected with a one ampere (1A) circuit breaker or fuse.

NOTE: Auxiliary microphone and headset jacks are **required** for a complete installation. These aid in troubleshooting and a back-up access to the aircraft radios.

2.3.3 PTT-ICS

The PM1200 is designed for noisy installations, such as open cockpit aircraft. In addition to the Advanced Microphone Processing (AMP) and IntelliVOX® squelch, the unit includes a VOX/PTT-ICS mode, controlled by the pushing the copilot volume knob. In this mode, no pilot mic audio is passed to the intercom unless pin 2 is connected to 16, or copilot mic audio unless pin 15 is connected to pin 2 through a normally-open, momentary switch (*not supplied*).

2.3.4 Music Input

Entertainment devices can be connected to the **PM1200**. Install a 1/8" jack convenient the pilot to connect the entertainment device into the system. Since the PM1200 is monaural, you may want to connect the left and right channels together at the music jack. Depending on the music source used, 10Ω resistors in series with the left and right channels may be desirable to avoid loading and possibly damaging the source.

A "Soft Mute" system is installed in the **PM1200** that will mute the music during intercom or radio activity.

WARNING: Local oscillators and other internal signals from CD or radio equipment can cause undesired interference with VHF navigation and communication equipment. Before takeoff, operate the entertainment device to determine if there is any adverse effect on aircraft systems. If any unusual operation is noted in flight, immediately switch the entertainment device off.

Note: Use the low level (or line) output from any music device to connect to the PM1200. *Maximum* input level is 2 V peak-to-peak.
DO NOT USE SPEAKER OUTPUT.
These levels will cause internal damage.

If the PM1200 is used with an expansion unit, music connected to the PM1200 will be heard in the panel unit and expansion unit in ALL intercom mode. Music connected to the expansion unit will *only* be heard by passengers in Crew mode. Connect music source to BOTH units to distribute the same music in both units.

2.3.5 Remote Configuration (11961)

The PM1200-Remote is designed for blind mounting. The unit can be controlled through two remote potentiometers for volume and two SPDT switches. Mount the volume controls in a location accessible to the pilot and copilot, and the VOX and ISO switches convenient to the pilot in command position. The pilot's volume pot also contains an on-off switch. See page 7 for wiring information.

NOTE: *Due to the exposed signal paths for the volume controls, these installations are more prone to electrical noise, and extreme care must be taken in constructing the harness, with wire runs as short as possible. PS Engineering does not guarantee a noise-free installation in this configuration. This version cannot be expanded.*

2.3.6 Expansion Configuration (11960-EXP)

The PM1200-EXP is configured internally to add expansion capability for more than two positions. Using an IntelliPAX expansion unit, part number 11616, an additional 6 intercom positions can be available.

Although not marked, the lower position on the ISO/ALL switch becomes a "Crew" position.

NOTE: *The IntelliPAX includes IntelliVOX intercom, but is not specifically designed for high noise environment. It may be desirable to have an intercom P-T-T, by installing an in-line, momentary normally open switch on the mic audio lines, or use a portable intercom P-T-T that have an open mic audio switch contact.*

2.4 Post installation checkout

After wiring is complete, verify power is ONLY on pin 14 of the connector, and airframe ground on pin 1. Failure to do so will cause internal damage and void PS Engineering's warranty.

1. Apply power to the aircraft and avionics.
2. Plug headsets into the pilot and copilot positions.
3. Verify that the pilot position can transmit and receive. With the **PM1200** in the OFF position (press the pilot's volume control knob to turn off).
4. Turn the unit on and rotate the pilot volume clockwise, about half way. Verify that the Pwr/Xmt light comes on, and shows green. If the LED is red, stop testing and trouble-shoot the microphone PTT installation.
5. Verify that the pilot can transmit and receive on the com transceivers.
6. Verify that the LED in the intercom changes from green to red when a radio PTT is pressed.
7. Verify proper intercom operation for pilot and copilot. For more information, consult Section 3.
8. Verify proper transmit and receive operation on the copilot position, noting that the copilot PTT switch allows proper transmission on the selected transceiver.
9. Verify proper Intercom system operation in the ALL and ISO modes.
10. Verify that the intercom system does not adversely affect any other aircraft system by systematically switching the unit on and off, while monitoring the other avionics and electrical equipment on the aircraft.
11. **PTT ICS**– Push the copilot volume control to activate the PTT-ICS mode. Verify that the mic audio is heard when the

intercom push to talk switch is activated.

Section 3 OPERATION

3.1 On/Off and Volume

Press the left hand knob to turn the unit on and off. This is also the fail-safe position. Whenever the unit is off, or power removed, the pilot's headset is connected directly to the aircraft audio system.

The pilot's volume control knob adjusts the loudness of the intercom and music for the pilot's headset only. It has no effect on aircraft radio volume level, allowing an additional degree of aircraft radio listening flexibility. The copilot's volume control adjusts the

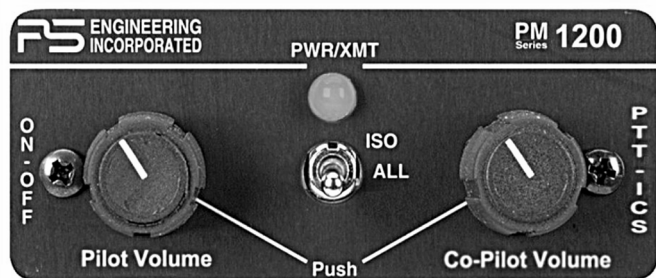

intercom volume for the copilot.

3.2 Squelch

The PM1200 incorporates PS Engineering's revolutionary Advanced Microphone Processing (AMP) and *IntelliVox*TM intercom squelch. No adjustment of the squelch control is required. Through individual signal processors, the ambient noise appearing in both microphones is constantly being sampled. Non-voice signals are blocked. When someone speaks, only their microphone circuit opens, placing their voice on the intercom.

The system is designed to block continuous tones, therefore people humming or whistling in monotone may be blocked after a few moments. The *IntelliVox*[®] is designed to work with normal aircraft cabin noise levels (70 dB and above). Therefore, it may not recognize speech and clip syllables in a quiet cabin, such as in the hangar, or without the engine running. This is normal. For best performance, the headset microphone **must** be placed within ¼ inch of your lips, preferably against them. It is also a good idea to keep the microphone out of a direct wind path. Moving your head through a vent air stream may cause the *IntelliVox*TM to open momentarily. This is normal.

For optimum microphone performance, PS Engineering, Inc. recommends installation of a Microphone Muff Kit (provided). This will not only optimize VOX performance, but will improve the clarity of all your communications

In some extremely high noise environments, it may be desirable to have a push to talk (PTT) intercom, instead of relying on voice-activation (VOX). In

the PM1200 audio panel the PTT intercom capability is added. To operate the PTT, push the PTT-ICS control switch on the copilot volume control. Using an external ICS PTT switch for pilot and copilot will allow voice on the intercom.

3.3 Mode Select

The center switch is a mode control that allows the pilot to tailor the intercom function to suit flight conditions. Regardless of configuration, the pilot will always hear the aircraft radio. **NOTE:** If there is a power failure to the **PM1200**, or if the power switch is turned off, the copilot will not hear the aircraft radio. Only the pilot is connected directly to the aircraft radio.

ISO (Up Position): The pilot is isolated from the intercom and is connected only to the aircraft radios. He will hear the aircraft radio reception (and sidetone during radio transmissions). Copilot and passengers will hear themselves and music but not the aircraft radio traffic.

ALL (Middle position): All parties will hear the aircraft radio, intercom, and music. However, during any ICS or radio communications, the music volume automatically mutes. The music volume increases gradually back to the original level after communications have been completed.

CREW (with expansion and 11960-EXP ONLY, down position, unlabeled): Pilot and copilot have access to aircraft radios, and hear Music input to PM1200. Passengers do not hear aircraft radio or pilot and copilot, but can talk to each other, and hear Music 2. In non-expanded systems, the down and middle positions operate the same way.

The music input on the expansion unit will only be active in Crew mode, otherwise, music from the PM1200 EXP will be heard by passengers.

Section 4 Warranty and Service

4.1 Warranty

In order for the factory warranty to be valid, the installations in aircraft must be accomplished by an FAA- certified avionics shop and authorized PS Engineering dealer. If the unit is being installed by a non-certified individual a factory-made harness must be used for the warranty to be valid.

PS Engineering, Inc. warrants this product to be free from defect in material and workmanship for a period of one year from the date of sale. During this one year warranty period, PS Engineering, Inc., at its option, will send a replacement unit to the PS Engineering dealer, if the unit should be determined to be defective after consultation with a factory technician. PS Engineering will not ship to the end user under warranty, unless authorized by the dealer.

This warranty is not transferable. Any implied warranties expire at the expiration date of this warranty. PS Engi-

neering SHALL NOT BE LIABLE FOR INCIDENTAL OR CONSEQUENTIAL DAMAGES. This warranty does not cover a defect that has resulted from improper or unreasonable use or maintenance as determined by us. This warranty is void if there is any attempt to disassemble this product without factory authorization. This warranty gives you specific legal rights, and you may also have other rights which may vary from state to state. Some states do not allow the exclusion of limitation of incidental or consequential damages, so the above limitation or exclusions may not apply to you.

4.2 Factory Service

The **PM1200** is covered by a one-year limited warranty. See warranty information.

Call PS Engineering, Inc. at (865) 988-9800 before you return the unit. This will allow the service technician to provide any other suggestions for identifying the problem and recommend possible solutions.

After discussing the problem with the technician and you obtain a **Return Authorization Number**, ship product to:

PS Engineering, Inc.
 Attn: Service Department
 9800 Martel Road
 Lenoir City, TN 37772
 (865) 988-9800 FAX (865) 988-6619.

NOTE:

PS Engineering is not responsible for units shipped US Mail.

If no method of payment is provided, the units will be returned COD. If no RMA or description of problem is present, the shipment will be refused.

PM1200 Remote P/N 11961
 installation drawing (not to
 scale)

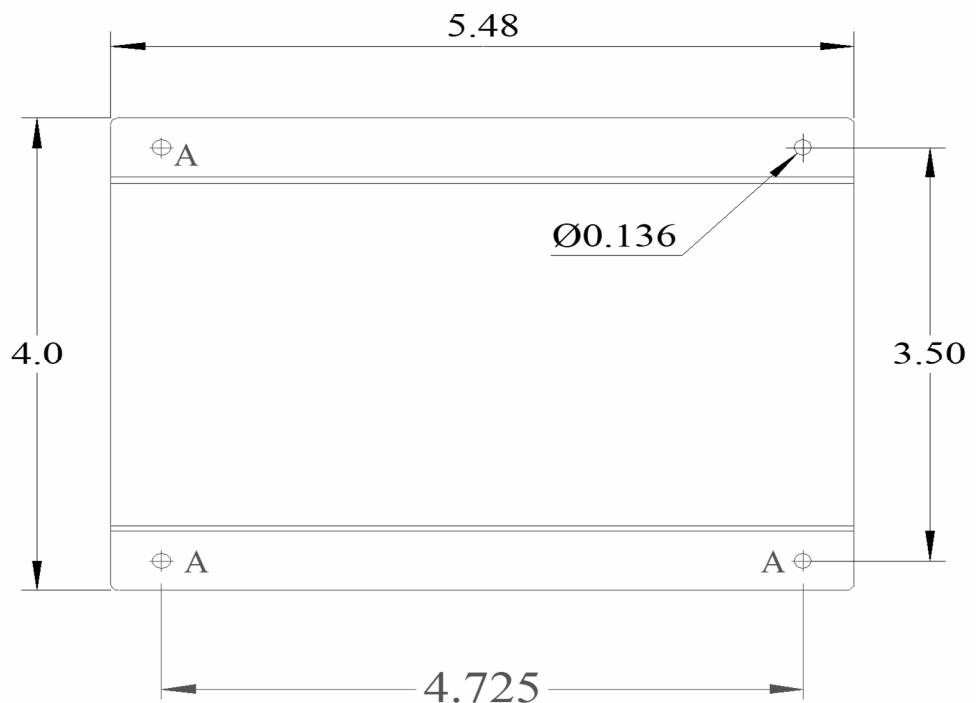

PM1200, With EXPANSION Wiring P/N 11960-EXP Only

11960 Sub-D DB-25 Female on unit, Male on harness

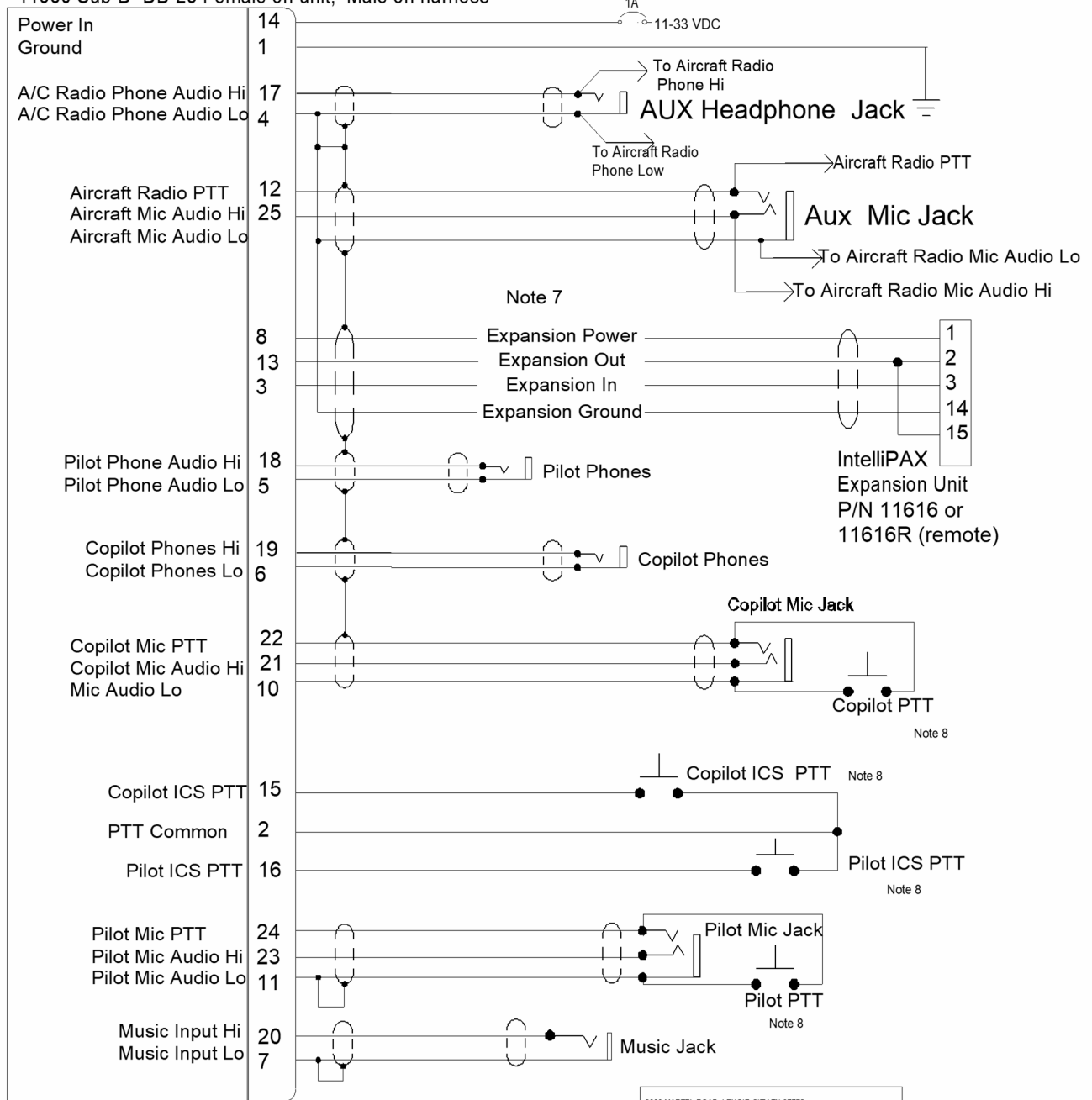

- NOTES:**
1. All wire must conform to MIL-22759 or 27500. Minimum 24 gage shielded wire.
 2. Use 2- and 3-conductor with shield as indicated.
 3. Use insulating washers on all jacks.
 4. Connect shields at intercom end only
 5. AUX headphone and microphone jacks are required.
 6. UNIT MUST BE COMPATABLE WITH EXPANSION, P/N 11960-EXP
 7. Music connected to the PM1200 will appear in Expansion when in "ALL" mode. Music connected to expansion will be present in passenger headset only in "Crew" mode. One music source can be connected to BOTH, if left and right channel isolation is considered.
 8. Radio and ICS PTT switches NOT supplied.

9800 MARTEL ROAD, LENOIR CITY TN 37772			
TITLE: PM1200 Expansion (11960E) WIRING			
SIZE:	DOCUMENT NUMBER:	REV:	
	120-196-0100	4	
DATE:	1/24/11	SHEET:	1 OF 1

PM1200, REMOTE Wiring P/N 11961

PM1200R 11961 Sub-D DB-25 female unit, male on harness

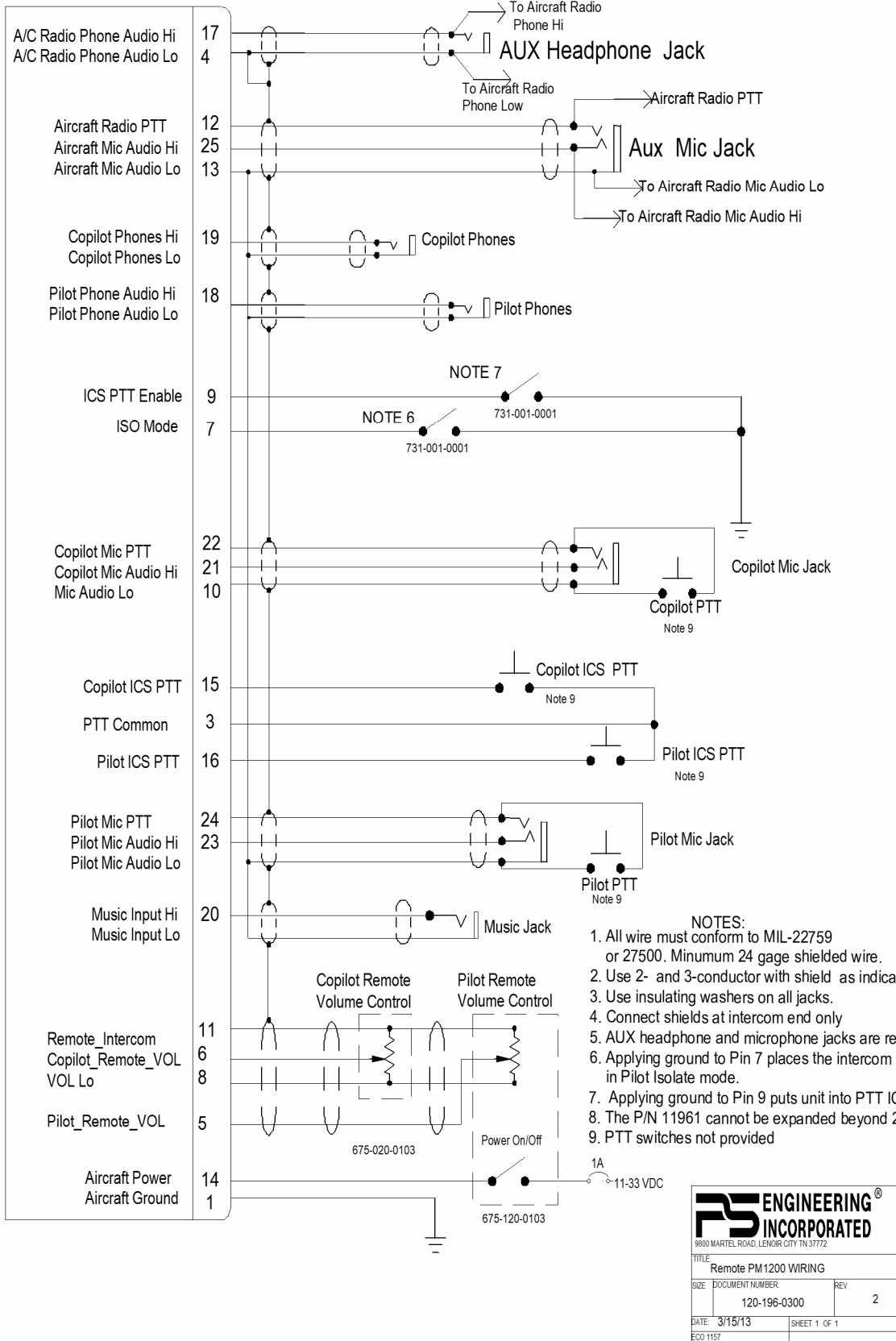

PS ENGINEERING®
INCORPORATED
9800 MARTEL ROAD, LENOIR CITY TN 37772

TITLE		Remote PM1200 WIRING	
SIZE	DOCUMENT NUMBER	REV	
	120-196-0300	2	
DATE	3/15/13	SHEET 1 OF 1	
ECC 1157			

PM1200, P/N 11960 Wiring

11960 Sub-D DB-25 Mating Connector is Male

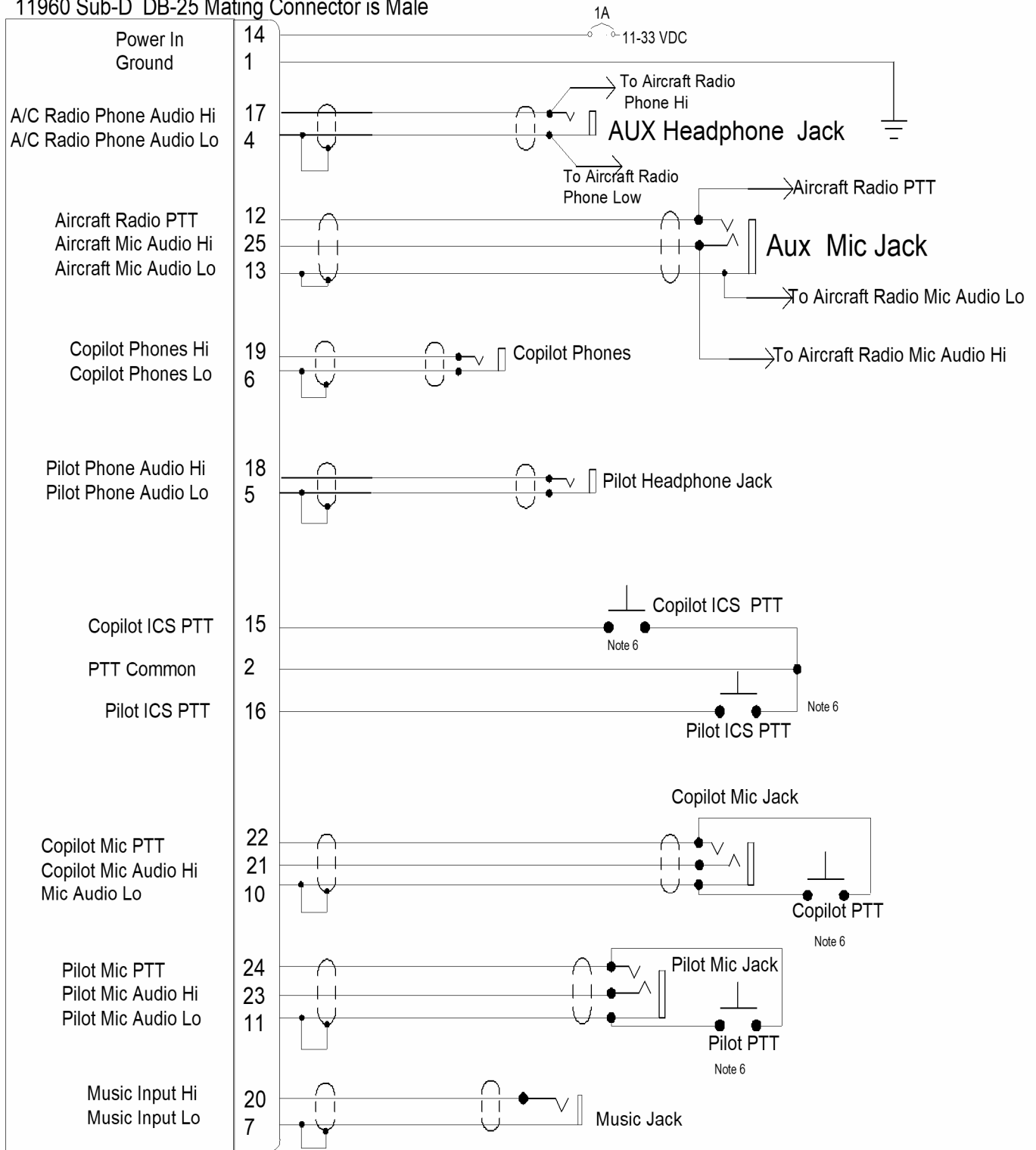

- NOTES:
1. All wire must conform to MIL-22759 or 27500. Minimum 24 gage shielded wire.
 2. Use 2- and 3-conductor with shield as indicated.
 3. Use insulating washers on all jacks.
 4. Connect shields at intercom end only
 5. AUX headphone and microphone jacks are required.
 6. Radio and ICS PTT switches not supplied

PS ENGINEERING[®] INCORPORATED		
<small>8800 MARTEL ROAD, LENOIR CITY TN 37772</small>		
TITLE: PM1200 Standard (11960) WIRING		
SIZE	DOCUMENT NUMBER: 120-196-0100	REV 1
DATE: 3/19/13	SHEET 1	OF 1
ECO 1157		