



9800 Martel Road
Lenoir City, TN 37772

www.ps-engineering.com

PAC45L

**Retrofit Audio Controller System
with MultiTalker® and IntelliVox®**



Document P/N 200-045-3000

Rev. 4, August 2023

Audio Control System with Intercom
System Installation and Operation Manual
FAA - TSO C139a

Patented under one or more of the following;
No. 4,941,187; 5,903,227; 6,160,496 and 6,493,450, 7,391,877

**In certified aircraft, warranty is not valid unless this product is installed by an
Authorized PS Engineering dealer.**

PS Engineering, Inc. 2023 ©
Copyright Notice

Any reproduction or retransmittal of this publication, or any portion thereof, without the expressed written permission of PS Engineering, Inc. is strictly prohibited. For further information, contact the Publications Manager at PS Engineering, Inc., 9800 Martel Road, Lenoir City, TN 37772. Phone (865) 988-9800, email contact@ps-engineering.com.

Table of Contents

Section I – GENERAL INFORMATION.....	1-1
1.1 INTRODUCTION.....	1-1
1.1.1 LIMITATIONS.....	1-1
1.2 SCOPE.....	1-1
1.3 EQUIPMENT DESCRIPTION.....	1-1
1.4 APPROVAL BASIS FAA TSO.....	1-1
1.1.2 LIMITATIONS.....	1-2
1.5 SPECIFICATIONS.....	1-2
1.6 EQUIPMENT SUPPLIED.....	1-3
1.8 CONFIGURATION.....	1-5
1.9 LICENSE REQUIREMENTS.....	1-5
Section II - INSTALLATION.....	2-1
2.1 GENERAL INFORMATION.....	2-1
2.1.1 SCOPE.....	2-1
2.1.2 CERTIFICATION REQUIREMENTS.....	2-1
2.2 UNPACKING AND PRELIMINARY INSPECTION.....	2-1
2.3 EQUIPMENT INSTALLATION PROCEDURES.....	2-1
2.3.1 COOLING REQUIREMENTS.....	2-1
2.3.2 MOUNTING REQUIREMENTS.....	2-1
2.3.3 AUDIO CONTROLLER CONNECTOR ASSEMBLY.....	2-2
2.4 CABLE HARNESS WIRING.....	2-2
2.4.1 ELECTRICAL NOISE.....	2-2
2.4.2 POWER.....	2-3
2.4.3 AUDIO CONTROLLER INTERFACE.....	2-4
2.4.4 BACKLIGHTING.....	2-4
2.4.5 UNSWITCHED INPUTS.....	2-5
2.4.6 COCKPIT VOICE RECORDER.....	2-6
2.4.7 SPEAKER OUTPUTS.....	2-6
2.4.8 AUDIO ALERTS.....	2-6
2.4.9 CTL45L WIRING.....	2-7
2.5 DISCRETE INPUTS.....	2-7
2.5.1 REMOTE ICS MODE CONTROL. (J452-45).....	2-7
2.5.1 OXY (P453-26 AND FRONT PANEL OXY).....	2-7
2.5.2 RECEIVE MUTE (J452-44).....	2-7
2.5.3 REMOTE ALERT ACKNOWLEDGE AND ALERT PROGRAMMING (P453-23).....	2-7
2.5.4 BACKLIGHT VOLTAGE AND DIMMER THRESHOLD.....	2-7
2.6 WIRED TELEPHONE/SATELLITE COMMUNICATION INPUT.....	2-8
2.7 USER ADJUSTMENTS.....	2-8
2.7.1 UNSWITCHED AUDIO LEVEL.....	2-8
2.7.2 ADJUSTMENTS.....	2-9
2.7.3 LOGIC SWITCH OPTIONS.....	2-9
2.7.4 LOGIC SWITCH DETAILS.....	2-12
2.7.5 FAIL-SAFE AUDIO AND REVERSIONARY MODE.....	2-17
2.7.6 MICROPHONE SETTINGS.....	2-17
2.7.7 ARTIFICIAL TRANSMIT SIDETONE.....	2-18
2.7.8 UNSWITCHED AUDIO.....	2-18
2.7.9 HEADPHONE OPTIONS.....	2-18
2.7.10 RECEIVE SIGNAL INDICATOR (RXI).....	2-18
2.7.11 MUSIC FUNCTIONS.....	2-18
2.7.12 SPEAKER ALERT AUDIO.....	2-19
2.7.13 BACKLIGHT DIMMER VOLTAGE.....	2-19
2.7.14 OTHER SHARED FUNCTIONS.....	2-19
2.8 PAC45L PIN ASSIGNMENTS.....	2-23
2.9 WIRING CHECKOUT.....	2-24

PS Engineering
PAC45L Audio Selector Panel and Intercom System
Installation and Operator's Manual

2.10 OPERATIONAL CHECKOUT 2-25

2.10.1 REQUIRED TEST EQUIPMENT 2-25

2.10.2 AUDIO CONTROLLER TEST 2-25

2.10.3 BLUETOOTH CHECKOUT 2-26

2.11 FINAL INSPECTION 2-26

Section III OPERATION..... 3-1

3.1 SCOPE..... 3-1

3.2 POWER AND FAIL SAFE 3-1

3.3 COMMUNICATIONS TRANSMIT (XMT) SELECTION 3-1

3.4 COM AUDIO SELECTOR 3-2

3.4.4 MONITOR MODE (CTL45L J7, SWITCH 4) 3-3

3.5 NAVAID SELECTION..... 3-3

3.5.1 IDENT FILTER..... 3-3

3.6 OXY (P453-26 AND FRONT PANEL OXY) 3-3

3.7 INTERCOM OPERATION (8)..... 3-3

3.7.1 *INTELLI*VOX® INTERCOM VOX-SQUELCH..... 3-3

3.7.2 INTERCOM VOLUME CONTROL..... 3-3

3.7.3 INTERCOM MODES- FRONT PANEL ICS BUTTON..... 3-4

3.8 SPEAKER OPERATION 3-4

3.9 BLUETOOTH® CONNECTION..... 3-4

3.9.1 PAIRING AND UNPAIRING BLUETOOTH DEVICES 3-4

3.9.2 BLUETOOTH® TELEPHONE (SAT) MODE..... 3-4

3.9.3 MUSIC MUTING CONTROL..... 3-5

3.10 WIRED SATCOM/CELL PHONE INPUT..... 3-5

3.11 AURAL ALERT AUDIO..... 3-5

3.11.1 STORING ALERT AUDIO..... 3-5

Section IV – Warranty and Service

4.1 WARRANTY 4-1

4.2 FACTORY SERVICE 4-1

Appendix A – PAC45L Installation Drawings A

Appendix B – Radio Interconnect Wiring B

Appendix C – Intercom Interconnect Wiring C

Appendix D – Control Head Interconnect Wiring D

Appendix E, Unit Connector Wiring Reference E

9.1 J451 CONNECTIONS..... E

9.2 J452 CONNECTIONS..... E

9.3 J453 CONNECTIONS..... E

9.4 J454 CONNECTIONS..... E

Appendix F – Instructions for FAA Form 337 and continuing airworthiness..... F

10.1 INSTRUCTIONS FOR FAA FORM 337, AUDIO CONTROLLERS..... F

Appendix G – RTCA DO160G Environmental Qualification Form G

11.1 MODEL NUMBER PAC45L AUDIO SELECTOR PANEL/INTERCOM REMOTE HUB..... G

11.2 INSTRUCTIONS FOR CONTINUING AIRWORTHINESS, AUDIO SYSTEM..... G

11.3 MODEL NUMBER CTL45L, AUDIO SELECTOR CONTROL PANEL..... G

Revision History

Rev	Date	Change
New	April 2021	Initial Release
1	July 2022	Updated Radio Wiring diagram
2	November 2022	Revised ICS passenger wiring diagrams for clarity, added Day/Night §2.4.1, more circuit breaker information § 2.4.2
3	February 2023	Added FOD covers
4	August 2023	Added DIP switch details to §2.7.14

Section I – GENERAL INFORMATION

1.1 INTRODUCTION

The PAC45L represents an evolution in the well-received PAC45 Series of audio controllers for legacy jet aircraft. MultiTalker®, using licensed U.S. Air Force patented technology, provides True Dimensional Sound, helping pilots to more easily discern from simultaneous radio receptions.

1.1.1 Limitations

This article meets the minimum performance and quality control standards required by a technical standard order (TSO). Installation of this article requires separate approval. Refer to Advisory Circular 20-41A for information on TSO installation approval.

Operation is subject to the following conditions:

- This device may not cause harmful interference.
- This device must accept any interference received, including interference that may cause undesired operation.

1.2 SCOPE

This manual provides installation and operation instructions for the PS Engineering PAC45L-series of Audio Selector Panel/Intercom Systems. This includes the following units:

Model Number	Description	PS Engineering Part Number
HUB45AR	Remote-mounted Audio Hub for analog I/O and processing	050-045-1001
CTL45L	Panel Mounted Control Head for Flight Crew – Black Bezel	050-441-3XXX
CTL45L	Panel Mounted Control Head for Flight Crew – Gray Bezel	050-441-4XXX

1.3 EQUIPMENT DESCRIPTION

The PAC45L is a state-of-the-art audio isolation amplifier and audio selector that contains an automatic voice activated (VOX) intercom system. It can switch up three transceivers (COM 1 to 3), a Satellite and eight navigation receivers (AUX 1 to 8) that can be configured as desired.

There are up to five unswitched inputs, available for traffic or EGPWS, autopilot disconnect, and/or radar altimeter warning.

In addition to a radio master volume, the individual volume controls select the receiver audio source provided to the headphones when selected to the “out” position.

A nine-station voice activated (VOX) intercom is included in the PAC45L. This system has PS Engineering’s patented *IntelliVox*® circuitry that eliminates manual adjustments. The intercom system incorporates pilot isolate, all and crew modes, a stereo music input with "SoftMute™".

In the PAC45L, a Bluetooth® wireless interface is available for wireless telephone and music connection.

Up to nine programmable alerts can be triggered by external sources to provide additional capability.

1.4 APPROVAL BASIS FAA TSO

FAA TSO The PAC45L-series Audio Selector Panels is FAA authorized under TSO C139A (Audio Amplifiers), ED-14C/DO-160G (*Environmental Conditions and Test Procedures for Airborne Equipment*), ED12B/DO-178C, Level C (*Software Considerations for Airborne Equipment*) and ED- 18/DO-214A (*Audio Systems Characteristics and Minimum Operational Performance Standards for Aircraft Audio Systems*).

1.1.2 Limitations

This article meets the minimum performance and quality control standards required by a technical standard order (TSO). Installation of this article requires separate approval.

Refer to Advisory Circular 20-41A for information on TSO installation approval.

Operation is subject to the following conditions:

This device may not cause harmful interference.

This device must accept any interference received, including interference that may cause undesired operation.

1.5 SPECIFICATIONS

TSO COMPLIANCE		
<i>Audio Selector/Intercom:</i>	FAA TSO-C139A	
APPLICABLE DOCUMENTS:	RTCA/DO-214A RTCA/DO-160G RTCA/DO-178C	
<i>Temperature Range:</i>	HUB45AR	CTL45L
Operating:	-45° C to +55°C	-20°C to +55°C
Short Term Operating:	-45° C to +71°C	-40° C to +70°C
Survival:	-55° C to +85°C	-55° C to +85°C
<i>Altitude:</i>	Up to 55,000 feet in a non-pressurized area of the cockpit.	
DIMENSIONS:	CTL45L: Height: 1.88 in. (4.78cm) Width: 4.90 in. (12.45 cm) Depth behind panel: 2.35 in. (5.97) HUB45AR: Height: 1.9" Width: 5.88 w/mounting flanges, Length 7.22", 12" w/ all connectors. See Figure 5-6	
UNIT WEIGHT		
HUB45AR	2.0 lbs. (.91 kg)	
CTL45L	1.0 (.45 kg)	
POWER REQUIREMENTS:		
<i>Voltage:</i>	18 to 33 VDC	
<i>Maximum Current:</i>	HUB45AR 1.5 Amp (Externally protected by a 5 Amp circuit breaker.) CTL45L 500 mA (Externally protected by a 1 Amp circuit breaker)	
<i>Typical Current</i>	750 mA	
<i>Alert Power</i>	<20 mA	
<i>Failsafe Power</i>	<10mA	
<i>Lighting</i>	< 5mA	
Audio Selector Specifications		
<i>Audio selector panel input impedance:</i>	510 Ω	
<i>Input Isolation:</i>	-60 dB (min.)	
<i>Switched Receiver Inputs:</i>	11 (COM 1– COM 3, SAT, AUX 1- 8)	
<i>Unswitched Inputs:</i>	5	
<i>Transmitter Selections:</i>	3 (COM 1, 2, 3)	
<i>Headphone Impedance:</i>	150 – 600 Ω or 8 Ω	
<i>Headphone Output:</i>	200 mW into 150Ω or 8Ω headset, no clipping <.5% THD typical	
<i>Microphone Impedance:</i>	150 - 600 Ω	
<i>PA Output, Cockpit speaker output</i>	10W @4 Ω	

PS Engineering
PAC45L Audio Selector Panel and Intercom System
Installation and Operator's Manual

Intercom Specifications	
<i>Intercom Positions:</i>	Up to 9 places (with individual <i>IntelliVox</i> ® circuits)
<i>Distortion:</i>	<1% THD @ 200 mW into 150Ω
<i>Mic Freq. Response, ±3 dB:</i>	300 Hz - 6000 Hz
<i>Music Inputs:</i>	1 (Stereo) plus Bluetooth
<i>Music Muting:</i>	>-30 dB "Soft Mute" when Com or intercom active.

1.6 EQUIPMENT SUPPLIED

The following units comprise the PAC45L System:

Model	Description	Part Number
HUB45AR	Remote-mounted Audio Hub for analog I/O and processing	050-045-1001
CTL45L	Control Head for pilot or copilot positions – Black	050-441-3XXX
CTL45L	Control Head for pilot or copilot positions – Gray	050-441-4XXX

Where -XXX will be the LRU P/N with custom Bezel Decal (text)

PAC45L Installation Kit: 250-045-0811

Male Connector Kit 250-045-8377 (P452, P454)				
Part Number	Description	MFR	MFR PN	Quantity
625-015-1503	Connector Back shell DB26 pin	Harting	09-70-015-0343	1
625-037-3703	Connector Back shell DB62 pin	Harting	09-67-037-0343	1
425-026-5601	Male Connector Shell DB26 pin	Harting	95-62-005-601	1
425-062-8177	Male Connector Shell DB62 pin	Harting	95-64-005-601	1
425-044-2043	Hi-density Male Pins	AMP	204370-2	88

Female Connector Kit 250-045-8477 J451, J453)				
Part Number	Description	MFR	MFR PN	Quantity
625-015-1503	Connector Back shell DB26 pin	Harting	09-70-015-0343	1
625-037-3703	Connector Back shell DB62 pin	Harting	09-67-037-0343	1
425-026-1800	Female Connector Shell DB26 pin	NorComp	180-026-273L000	1
425-062-4701	Female Connector Shell DB62 pin	Harting	99-56-400-4701	1
425-030-7354	Hi-density Female Pins	Amphenol	M39029/57-354	88

9-Pin Connector Kit 250-045-0019 (P455)				
Part Number	Description	MFR	MFR PN	Quantity
625-009-9034	Connector Back shell DB9 pin	Harting	09-67-009-0343	1
425-009-0777	Male Connector Shell DB9 pin	Amphenol	L777-RR-E-09-P	9
425-020-5089	Standard Density Male Pins	Deutsch	M39029/64-369	9

PS Engineering
PAC45L Audio Selector Panel and Intercom System
Installation and Operator's Manual

CTL45L 9-Pin Female Connector Kit 250-543-0100 (J455)				
Part Number	Description	MFR	MFR PN	Quantity
625-009-9209	Connector Back shell DB9	Harting	09-67-009-0343	1
425-009-7709	Connector Female Shell DB9	Amphenol	L177-RR-E-09-S	1
425-020-5090	Standard density female pins	Deutsch	M39029/63-368	9

External Bluetooth Antenna

Part Number	Description	MFR	MFR PN	Quantity
300-045-1351	Bluetooth Coaxial Cable SMA ST BH JK to ST Plug RG 174/U 36	Amphenol	135110-02-36"	1
510-045-9602	Panel-Mounted Bluetooth Antenna	Taoglas	GW.26.0112.HT	1

Also included: FOD covers, 575-045-0162 (2 ea. rectangular, 0.1875"x 1.62") and 575-990-0050 (round, 1 ea.)

EQUIPMENT REQUIRED BUT NOT SUPPLIED

- a. Circuit Breakers: 1 ea.; 5 amp PULL TYPE REQUIRED for HUB45aAR, 1 A for CTL45Ls
- b. Optional Circuit Breakers: 1 ea.; 1 amp PULL TYPE REQUIRED for PAC45L aural alerts, 1 ea. 1 A for failsafe power
- c. Headphone Jacks (as Required)
- d. Microphone Jacks (as Required)
- e. Headphones, as required
- f. Microphones, as required
- g. Interconnect Wiring

1.8 Configuration

The PAC45L System is comprised of a single PAC45L HUB (HUB45AR) and up to four CTL45L Control Head “building blocks” to facilitate flexibility as well as simplicity.

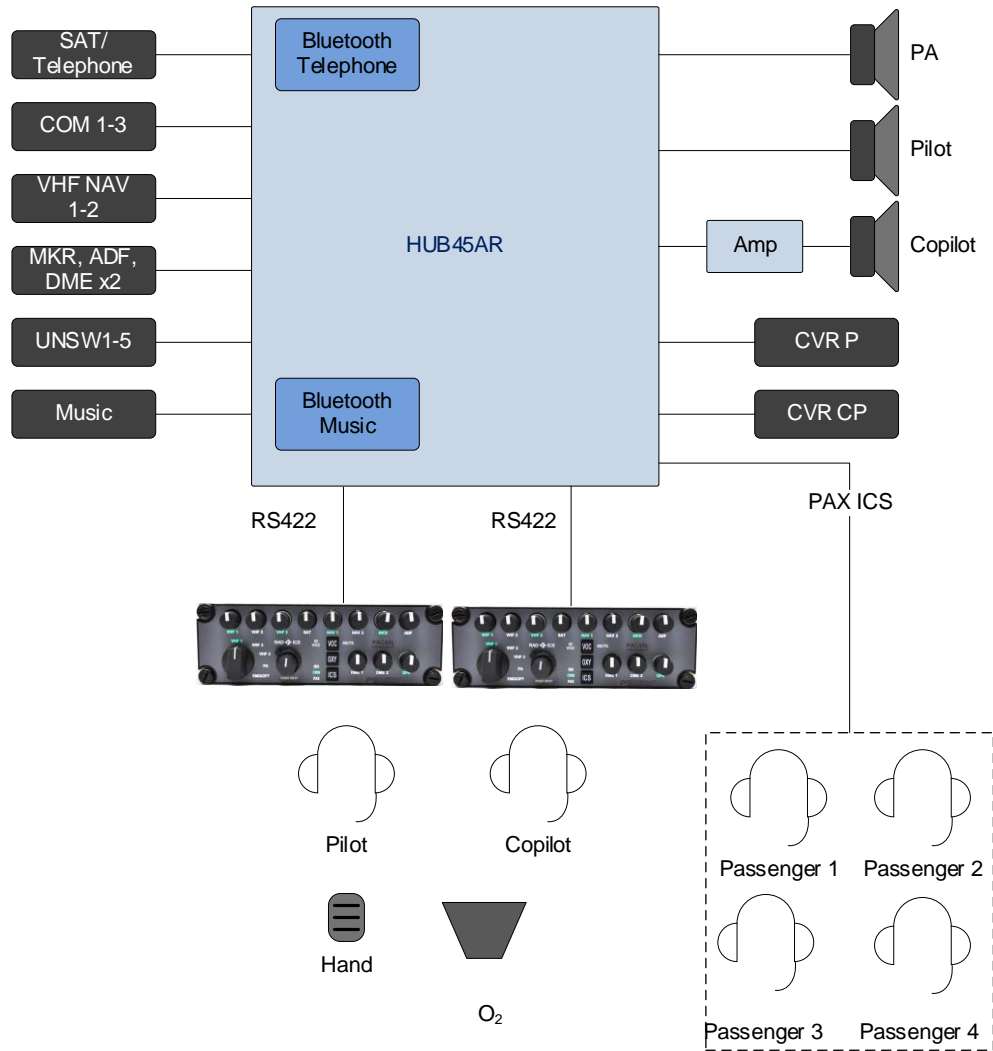

Figure 1-1 Baseline configuration

1.9 LICENSE REQUIREMENTS

None

Section II - INSTALLATION

2.1 GENERAL INFORMATION

2.1.1 SCOPE

This section provides detailed installation and interconnection instructions for the PS Engineering PAC45L Audio Selector Panel/Intercom.

Please read this manual carefully before beginning any installation to prevent damage and post-installation problems.

Installation of this equipment requires special tools, test equipment (refer to §2.12.1) and installer knowledge as required by 14 CFR 65.81 (b).

2.1.2 Certification Requirements

NOTE

The PAC45L requires specialized knowledge and tools for an effective installation. An appropriately rated Certified Aircraft Repair Station **must** install this equipment in accordance with applicable regulations. PS Engineering, Incorporated warranty is not valid unless the equipment is installed by an authorized PS Engineering, Incorporated dealer.

Failure to follow any of the installation instructions, or installation by a non-certified individual or agency will void the warranty and may result in an **unairworthy** installation.

This article meets the minimum performance and quality control standards required by a technical standard order (TSO). Installation of this article requires separate approval. Refer to AC 20-41A for information regarding Substitute TSO Aircraft Equipment.

2.2 Unpacking and Preliminary Inspection

Use care when unpacking the equipment. Inspect the units and parts supplied for visible signs of shipping damage. Examine the unit for loose or broken buttons, bent knobs, etc. Verify the correct quantity of components supplied with the list in §1.6. If any claim is to be made, save the shipping material and contact the freight carrier. Do NOT return units damaged in shipping to PS Engineering. If the unit or accessories show any sign of external shipping damage, contact PS Engineering to arrange for a replacement. Under no circumstances attempt to install a damaged unit in an aircraft. Equipment returned to PS Engineering for any other reason should be shipped in the original PS Engineering packaging, or other UPS approved packaging.

2.3 Equipment Installation Procedures

2.3.1 Cooling Requirements

Forced air-cooling of the PAC45L is not required. However, the units should be kept away from heat producing sources (i.e., defrost or heater ducts, dropping resistors, heat producing avionics) without adequate cooling air provided.

2.3.2 Mounting Requirements

The HUB45AR must be rigidly mounted to the aircraft structure in an avionics-rated location. The CTL45L is designed for Dzus-rail mounting within view and reach of the flightcrew position(s). Installation must comply with FAA Advisory Circular AC 43.13-2B, or other FAA-approved aircraft technical data. The unit may be mounted in any area where adequate clearance for the unit and associated wiring bundle exists.

To prevent noise, avoid installing the unit close to high current devices or systems with high-voltage pulse type outputs, such as DME or transponders. Avoid running the interconnecting bundles near any high current wires.

2.3.3 Audio controller connector assembly

The HUB45AR LRU connectors mate with two 62-pin, and two 26-pin connectors. One of each gender. The connectors are a sub-miniature crimp-type, and require the use a hand crimp tool, from table below (or equiv.).

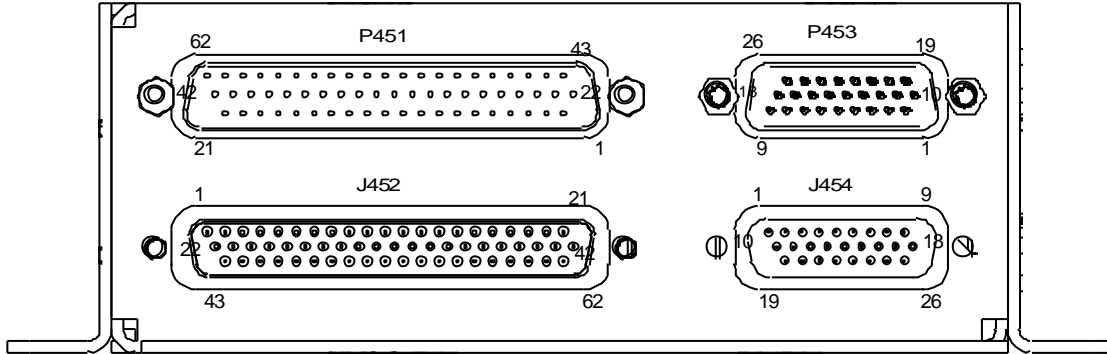

Figure 2-1 - PAC45L Connector Layout

Insert the screw or thumbscrews through the top half of the shell (B) and apply the E-Ring to the unthreaded portion and bend the E-ring holder back and forth to break it from the holder. Repeat for the other side.

Place the harness and connector in the bottom portion (A) and fold the retaining parts over the wires. Install the top shell (B) by inserting the screws through the connector and snapping the top over the bottom until the lances are in the cutouts. Be sure to align the lip of the shell over the connector edge before snapping in place. Slide the cover nut over the two halves and screw in place.

Ensure that proper strain relief and chafing precautions are made during wiring and installation.

Manufacturer	Crimping Tool	Positioner	Extraction tool
AMP	601966-1	601966-6	91067-1
Daniels	AFM8	K42	M24308-1
ITT-Cannon	995-0001-584	995-0001-739	91067-1

Table 2-1 Connector Pin crimping tools

2.4 Cable Harness Wiring

Referring to the appropriate Appendix, assemble a wiring harness as required for the installation. All wires must be MIL-SPEC in accordance with current regulations. Two- and three-conductor shielded wire must be used where indicated and be MIL-C-27500 or equivalent specification. Proper stripping, shielding and soldering technique must always be used. It is imperative that correct wire be used.

Refer to FAA Advisory Circular 43.13-2B for more information. Failure to use correct techniques may result in improper operation, electrical noise or unit failure. Damage caused by improper installation will void the PS Engineering warranty.

See Appendix C and D for intercom connection configurations. It is critical to the proper operation of this system to have this connector wiring made in accordance with these diagrams. Use 2- and 3-conductor, MIL-spec cable as shown. Connect the shields at the audio controller end only, and tie to the audio low inputs as shown.

2.4.1 Electrical Noise

Due to the variety and the high power of radio equipment often found in today's aircraft, there is a potential for both radiated and conducted noise interference.

The PAC45L power supply is specifically designed to reduce conducted electrical noise on the aircraft power bus by at least 50dB. Although this is a large amount of attenuation, it may not eliminate all noise, particularly if the amplitude of noise is very high. Shielding can reduce or prevent radiated noise (i.e., beacon, electric gyros, switching power supplies, etc.) However, installation combinations can occur where interference is possible. The PAC45L was designed in an RFI hardened chassis and has internal Electromagnetic Interference (EMI) filters on all inputs and outputs.

Ground loop noise occurs when there are two or more ground paths for the same signal (i.e., airframe and ground return wire). Large cyclic loads such as strobes, inverters, etc., can inject noise signals onto the airframe that are detected by the audio system. Follow the wiring diagram very carefully to help ensure a minimum of ground loop potential. Use only Mil Spec shielded wires (MIL-C-275000, or better). Under no circumstances, combine a microphone and headphone wiring into the same shielded bundle. Always use a 2- or 3-conductor, shield wire as shown on the installation-wiring diagram.

The shields can be daisy-chained together, and then connected to the ground.

Radiated signals can be a factor when low-level microphone signals are "bundled" with current carrying power wires. Keep these cables physically separated. It is very important that you use insulated washers to isolate the ground return path from the airframe to **all** headphone and microphone jacks.

2.4.2 Power

The PAC45L system is compatible with 28 Volt DC systems. A five (5) Amp circuit breaker is required for all installations. Power and ground wires should be #22AWG connect power to P451 Pin 42. Connect airframe ground to P451 Pin 20 and 21 only.

Power consumption is as follows:

At 28V:

- Control head Only: 400 mA
- Hub Only: 750 mA
- Alert audio power: 20mA

At minimum input voltage (20V):

- Control head: 600mA
- Hub Only: 950mA

Lighting input: <5mA

Alert Power <100mA (May be connected through a separate 1A circuit breaker.)

Failsafe Power <10mA(May be connected through a separate ½ A circuit breaker.)

It is up to the installer to determine the circuit breaker arrangement. Removing power from the hub will place the audio controller in failsafe, but the O₂ microphone and alert circuits can function is power is available on those respective inputs.

Likewise, each control head can be independently powered through a 1A circuit breaker. When power is removed from an individual control head, other powered control heads will function in reversionary mode, if configured.

- HUB45A ONLY breaker should be not less than 3 amps
- HUB45A & CTL45L (only 1 CTL45L) should be no less than 4 amps
- CTL45L ONLY breaker should be not less than 1 amp for one unit
- CTL45L ONLY breaker should be not less than 2 amp for two units

CAUTION: Do not connect or disconnect (HOT SWAP) any components with power applied, this may damage the units

2.4.2.1 Alert power, P451 Pin 41,

The PAC45L has an independent alert system with the ability to play alerts even when the audio controller is powered off. To take full advantage of this isolation a separate one (1) Amp circuit breaker is required. Power should be #22AWG connect power to P451 Pin 41.

When power to P451-42 is present, the message will play three times or until the remote acknowledge is selected.

2.4.2.2 Failsafe Power P451 Pin 62 and O₂ Enable P453 Pin 26

When connected to the aircraft bus, it allows for the use of Oxygen microphones in failsafe, when the O₂ microphone discrete, J453 Pin 26 is grounded.

2.4.3 Audio controller interface

The PAC45L is designed to interface with standard aircraft avionics and presents a 510 Ω receiver impedance. For best results, a twisted-shielded cable is recommended from the avionics audio source to the audio controller, with the shield grounded at the audio controller end.

Some avionics do not provide a separate audio low and may introduce additional electrical noise into the system. For best results, connect the audio low from the audio controller to the radio ground, using one conductor of the twisted-shielded cable.

2.4.3.1 Front Panel Nomenclature and Audio Inputs

Due to the PAC45L flexibility with label nomenclature (custom labels) the naming of the inputs and respective control locations can change. See Appendix B – Radio Interconnect Wiring, and §2.8, Pin Assignments for the Switch Positions associated with the respective inputs.

NOTE: Navaid selection is as follows:

- Nav 1 controlled via NAV 1 knob.
- Nav 2 controlled via NAV 2 knob.
- MKR 1 & MKR 2 controlled via MKR knob.
- ADF 1 & ADF 2 controlled via ADF knob.
- DME 1 controlled via DME 1 knob.
- DME 2 controlled via DME 2 knob.

2.4.3.1.1 Navaid Ident Filter (front panel VOC)

The PAC45L Systems is equipped with an identifier filter that will enhance the 1030 Hz Morse Code identifier (ID Mode), or reduce the Morse Code identifier for clearer reception of voice transmissions or VOR (VOC).

The ident filter is added to Nav 1, NAV 2 and ADF inputs.

2.4.3.2 Installation with Monaural Headsets

Not recommended, because the benefit of MultiTalker® is lost.

*However, if desired, the PAC45L can be installed monaurally by using **the right and left outputs together**. However, the HUB45AR DIP switches must be set for Mono configuration. See §2.5.3.*

2.4.4 Backlighting

Control of the unit backlighting is through the aircraft avionics dimmer through a single connection to the HUB45A. A serial message is sent to the control heads to adjust the dimming.

For lighting control, connect J452-22, wrt J452-1 to aircraft dimmer.

Backlight voltages of 5 VDC, 14 VDC and 28 VDC are configurable. See §2.5.4.



2.4.4.1 Backlight Adjustment, (HUB45A with Serial Number CH45A1208 and above)

Mode	Operation
Night Mode and Day Mode	<p>Night Mode: Dimmer pot (above trip level) adjusts brightness from minimum to full brightness as set by programming pots.</p> <p>Day Mode: Below trip level sets brightness to full brightness as set by programming pots (separate settings from Night Mode settings).</p>
Night Mode Only	Dimmer pot (trip level adjusted to zero) adjusts brightness from minimum to full brightness as set by programming pots.
Day Mode Only	No dimmer pot connected, sets brightness to full brightness as set by programming pots.

Here's how to setup the dimming values:

1. Long press (>1 second) OXY and ICS buttons.
2. One chime is heard in Pilot's headset. You can now set Green (#14) and White (#15) adjustment pots for Night Mode.
3. Long press OXY and ICS buttons again.
4. Two chimes are heard. You can now set Green and White adjustment pots for Day Mode.
5. Long press OXY and ICS buttons again.
6. Three chimes are heard. This exits the dimmer setup mode. Green and White Adjustment pots are inactive when not in setup mode.
7. Trip level pot (#13) can be adjusted any time before or after Green/White dimmer setup. This pot is inactive during Green/White dimmer setup mode, otherwise it is always active.

Other things to note:

1. Night mode sets the Maximum brightness level for the external dimming control pot when it is above the trip threshold.
2. Day mode sets the brightness level for the external dimming control pot when it is below the trip threshold.
3. During Green/White setup, the external dimmer brightness control pot is inactive.
4. During Green/White setup, Green/White adjustments are adjusting the Maximum level that can be set by the external dimmer brightness control pot during normal operation.
5. Once dimmer setup mode is entered it will automatically exit the mode and play 3 Chimes after 60 seconds of inactivity, where activity is defined as a long press of dual HRTF and ACK buttons, or movement of either the Green or White adjustment pots.

2.4.5 Unswitched inputs

These inputs are presented to the pilot and copilot regardless of the audio configuration and will always mute the crew entertainment inputs. These 510Ω inputs can be used for altimeter DH audio, TAWS audio, TCAS audio or any other critical audio signal.

Unswitched #1 is always presented to the crew headphones and is available to the pilot in fail-safe (off) mode. Unswitched #2 is presented to the copilot in fail-safe.

Unswitched Input	Input Pins	Hear in Fail Safe	Hear in Headset
1	P452 - 55 WRT 15	Pilot	Pilot & Copilot
2	P452 - 35 WRT 16	Copilot	Copilot
3	P452 - 56 WRT 17	No	Pilot & Copilot
4	P452 - 36 WRT 18	No	Pilot & Copilot
5	P452 -57 WRT 19	No	Pilot & Copilot

Table 2-2 Unswitched inputs

2.4.6 Cockpit Voice Recorder

The PAC45L audio controller contains a Cockpit Voice Recorder output for the pilot and copilot positions. The CVR output is consistent with RTCA DO-214A §1.5.7.

Pilot CVR output is J452-60; Copilot CVR output is P452-61, all with respect to any available audio low on J452.

See §2.7.14 for information on selecting low-level speaker or CVR outputs.

2.4.7 Speaker Outputs

The HUB45A is capable of providing three separate speaker outputs, plus Public Address. However, two are dual purpose and mutually exclusive with copilot CVR outputs.

Cockpit Speaker, P452-41 a 4Ω, 10W output, with the radio audio selected by the *Pilot's* CTL45L Control Panel.

When enabled, P452-40 is a low-level speaker output with the radio audio selected on the *Copilot's* CTL45L Control Panel.

Low Level audio can be amplified to 4Ω, 10W speaker output with a PSA210, Dual Channel speaker amplifier. See §2.7.14 for information on selecting CVR or low-level speaker outputs.

2.4.8 Audio Alerts

The PAC45L contains an independent audio alerting system that will play up to 9 messages that can be stored by the user (see §3.11.1). Factory stored default audio is shown below.

NOTE:

THESE MESSAGES ARE STRICTLY SUPPLEMENTAL AND OPTIONAL, AND SHALL NOT REPLACE ANY EXISTING ALERTS IN THE AIRCRAFT.

IT IS THE INSTALLERS' RESPONSIBILITY TO DETERMINE IF THIS ALTERATION IS MAJOR OR MINOR AND PROVIDE APPROPRIATE DOCUMENTATION (FORM 337, SUPPLEMENTS, ETC.)

The alert system has a power input (P451-41) that will keep the systems operable if the PAC45L systems power source is removed. Alert audio is provided in Fail-safe when power is on P451-62.

Alert Input	Input Pins	Alert Audio
1	P453 – 10	“Master Caution”
2	P453 – 11	“Alert”
3	P453 – 12	Chime
4	P453 – 13	1000 Hz tone
5	P453 – 14	Doorbell Chime
6	P453 – 19	Ring Tone
7	P453 – 20	“Timer at Zero”
8	P453 – 21	“Intercom Call”
9	P453 – 22	“ Check Engine Instruments”
Alert Power	P451 – 41	
Remote Acknowledge	P453 – 23	

The alert triggers can be configured to be Active High (>4.5 VDC) or Active Low (<0.5 VDC), and trigger at the leading-edge transition or by the voltage level. Active Low inputs should be less than 100 Ω when on and more than 10 k Ω when off. See §2.5.3 for configuration options.

Alerts with edge triggers will play continuously until the Acknowledge button (ACK) is pressed (remote ACK P454-23 grounded).

Alerts with level trigger will play continuously until the Acknowledge button (ACK) is pressed (remote ACK P454-23 grounded), or the input level reverts.

When power is applied to the alerts and not the PAC45L audio controller, it will play the message continuously until the remote acknowledge is selected.

The volume level of the alerts is adjustable with potentiometer 13 on the side of the HUB45AR (See §2.7.2)

Audio alerts are inhibited for the first 30 seconds after power up to reduce nuisance triggers.

2.4.9 CTL45L wiring

The PAC45L supports up to 2 CTL45L control heads.

CTL45L can be configured for 28VDC or 5 VDC dimming.

Set J7 switches to: off/off/on/off/off/off for 28 VDC Lighting

Set J7 switches to: on/on/on/off/off/off for 5 VDC Lighting



Figure 2-2 CTL45L Switch Locations

2.5 Discrete inputs

2.5.1 Remote ICS mode control. (J452-45)

When a momentary, normally open, push-button switch is connected between pin J452-45 and ground, it will change the intercom mode on the Pilot's PAC45L.

2.5.1 OXY (P453-26 and front panel OXY)

Activates the Oxygen Mask microphone inputs if configured.

2.5.2 Receive Mute (J452-44)

When J452-44 is grounded through a remote switch, **all** receive audio is muted. If this switch remains closed for more than 30 seconds (i.e., a stuck switch), the received audio will return to normal

2.5.3 Remote Alert Acknowledge and Alert Programming (P453-23)

A momentary switch connected to P453-23 serves as a remote Alert Acknowledge switch and **must** be used to program the Audio Alerts. We recommend installing provisions for this switch is audio alerts are ever used.

2.5.4 Backlight Voltage and Dimmer Threshold

The white (text) and green (indication) lighting can be adjusted independently along with the dimmer trip level.

See [§2.7.2](#) for locations.

Adjustment Pot #13 changes the Dimmer Threshold

Adjustment Pot #14 changes the Green LED intensity

Adjustment Pot #15 changes the White LED intensity

See Set switches 47 & 48 ON for dimmer 28V

Set switch 47 – **OFF** & 48- **ON** for 14V dimmer

Set switches 47 & 48 OFF for 5VDC dimmer

See [§2.7.3](#) for locations

By default, adjustments to the pot change the minimum trip point for the dimmer input to full bright. The pot permits adjustment from 0V to nominal dimmer voltage (28V or 5V depending on configuration).

2.6 Wired Telephone/Satellite Communication input

The PAC45L can accommodate a wired cell phone interface on J452 Pins 58, 59, and 38. Both Bluetooth and wired Telephone can be accommodated, however, only ONE can be active at a time. Low impedance satellite phones might require a tactical radio adapter, PS Engineering P/N 12100

Visit website (https://www.ps-engineering.com/assets/docs/radio_adapter.pdf)

2.6.1 Music Input

NOTE

Use the low-level output of any additional Music device to connect to the audio controller. Maximum signal level is **3 VAC** p-p. **DO NOT** use a speaker-level output; this will cause internal damage in the audio controller.

CAUTION

Local oscillators and internal signals from Music equipment can cause undesired interference with other aircraft systems. Before takeoff, operate the entertainment devices to determine if there is any adverse effect within the aircraft systems. If any unusual operation is noted in flight, immediately switch off the entertainment devices.

All additional entertainment devices must be switched off for both takeoff and landing.

2.7 User Adjustments

The PAC45L is factory set for typical installation. However, several installation adjustments are available. No computer is required.



2.7.1 Unswitched Audio Level

Unswitched inputs one through five are installation adjustable through the side of the PAC45L unit.

2.7.2 Adjustments

On the side of the PAC45L/HUB45AR are 15 adjustment potentiometers. **These are ALL 30-turn pots.** Remove any FOD protective covers as necessary from the adjustments. Replacements are included in the installation kit.

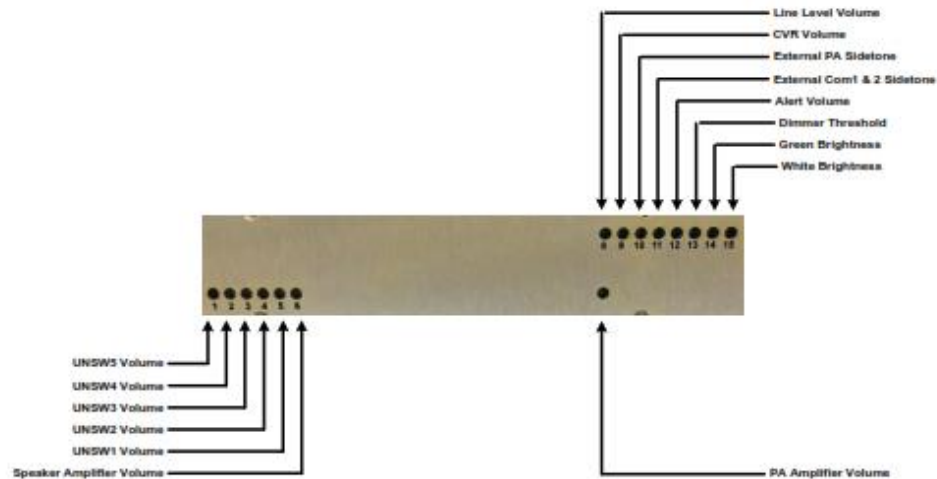

1. Unswitched input 5 volume (J452-57)
2. Unswitched input 4 volume (J452-36)
3. Unswitched input 3 volume(J452-56)
4. Unswitched input 2 volume(J452-35)
5. Unswitched input 1 volume (J452-55)
6. Speaker Amplifier Volume (J452-41)
7. PA Amplifier Volume (J452-42)
8. Copilot speaker output (if configured) and satcom telephone output volume (J452-38)
9. Cockpit Voice Recorder Volume (J452-60, 61)
10. External PA Sidetone (J452-37)
11. External COM 1 (J452-33)and COM 2 Sidetone (J452-34)
12. Alert volume (adjusts the level of the internal audio alerts and annunciations generated by the PAC45L)
13. Dimmer threshold (the minimum voltage when the lights go full bright, “day” mode).
14. Green backlight level, see §2.5.3
15. White backlight level

2.7.3 Logic Switch Options

The PAC45L has switches accessible through the side of the HUB45AR to set specific functions

PS Engineering
PAC45L Audio Selector Panel and Intercom System
Installation and Operator's Manual

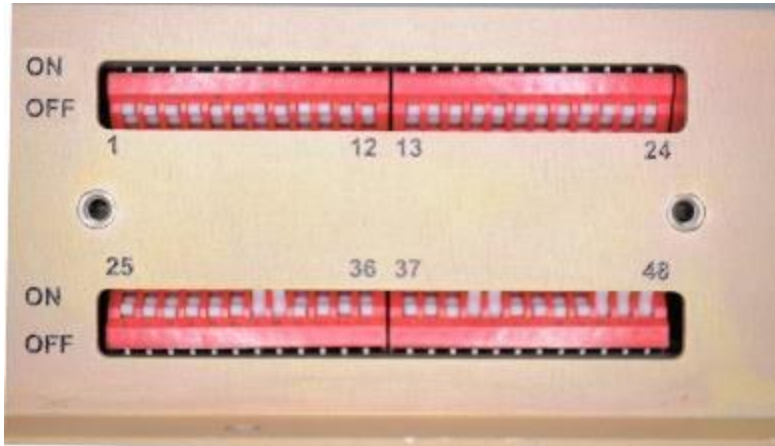

Switch functions and positions as shipped from the factory. The color coding denotes similar groups of functionality.

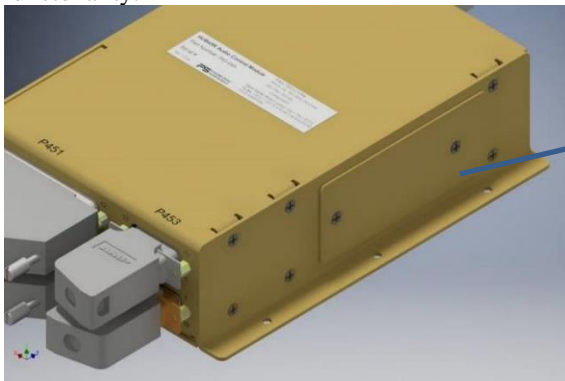

430-445-0082
Cover

PS Engineering
PAC45L Audio Selector Panel and Intercom System
Installation and Operator's Manual

TOP ROW			BOTTOM ROW		
SWITCH	FUNCTION	POSITION*	SWITCH	FUNCTION	POSITION*
1	FAILSAFE ALERTS TO CREW	ON	25	COPILOT CONTROL HEAD INSTALLED	ON
2	FAILSAFE ALERTS TO OBSERVERS	ON	26	OBSVR 1 CONTROL HEAD INSTALLED	ON
3	ALERTS TO CREW	ON	27	OBSVR 2 CONTROL HEAD INSTALLED	ON
4	ALERTS TO OBSERVERS	ON	28	REVERSIONARY MODE	ON
5	ALERT 1 TRIGGER	EDGE ON, LEVEL OFF	29	TRANSMIT MUTE	OFF
6	ALERT 1 POLARITY	POS ON, NEG OFF	30	STUCK MIC ENABLE	ON
7	ALERT 2 TRIGGER	EDGE ON, LEVEL OFF	31	HIGH MIC SENS	OFF
8	ALERT 2 POLARITY	POS ON, NEG OFF	32	PAX 1 & 2 = O ₂ MICS	OFF
9	ALERT 3 TRIGGER	EDGE ON, LEVEL OFF	33	PAX 3 & 4 = OBSVR O ₂ MICS	OFF
10	ALERT 3 POLARITY	POS ON, NEG OFF	34	COM 7 COM 8 Audio/COM 1 COM 2 SIDETONE	OFF
11	ALERT 4 TRIGGER	EDGE ON, LEVEL OFF	35	PA SIDETONE	OFF
12	ALERT 4 POLARITY	POS ON, NEG OFF	36	UNSW 1 & 2 SPLIT	OFF
13	ALERT 5 TRIGGER	EDGE ON, LEVEL OFF	37	UNSW OBSVR	ON
14	ALERT 5 POLARITY	POS ON, NEG OFF	38	STEREO OBSVR	ON
15	ALERT 6 TRIGGER	EDGE ON, LEVEL OFF	39	STEREO CREW	ON
16	ALERT 6 POLARITY	POS ON, NEG OFF	40	8 OHM HEADSETS	OFF
17	ALERT 7 TRIGGER	EDGE ON, LEVEL OFF	41	RECEIVER INDICATOR ON	ON
18	ALERT 7 POLARITY	POS ON, NEG OFF	42	MUSIC MUTE	ON
19	ALERT 8 TRIGGER	EDGE ON, LEVEL OFF	43	COPILOT MUSIC ENABLE	ON
20	ALERT 8 POLARITY	POS ON, NEG OFF	44	OBSERVER 1 MUSIC ENABLE	ON
21	ALERT 9 TRIGGER	EDGE ON, LEVEL OFF	45	OBSERVER 2 MUSIC ENABLE	ON
22	ALERT 9 POLARITY	POS ON, NEG OFF	46	ALERTS ON SPEAKER	ON
23	RESERVED	OFF	47	DIMMER 28V	ON
24	RESERVED	OFF	48	DIMMER 28V	ON

2.7.4 Logic Switch Details

SWITCH NUMBER	FUNCTION	ON	OFF
1	FAILSAFE ALERTS TO CREW	PILOT AND COPILOT HEAR ALERTS IN FAILSAFE MODE	NO ALERT AUDIO IN FAILSAFE (RADIOS ONLY)
2	FAILSAFE ALERTS TO OBSERVER	OBSERVER STATIONS HEAR ALERTS IN FAILSAFE MODE	NO AUDIO IN FAILSAFE
3	ALERTS TO CREW	PILOT AND COPILOT HEAR ALERT AUDIO	PILOT AND COPILOT DO NOT HEAR ALERT AUDIO
4	ALERTS TO OBSERVERS	OBSERVER STATIONS HEAR ALERT AUDIO	OBSERVER STATIONS DO NOT HEAR ALERT AUDIO
5, 7, 9, 11, 13, 15, 17, 19, 21	ALERT TRIGGER	EDGE TRIGGERED	LEVEL TRIGGERED
6, 8, 10, 12, 14, 16, 18, 20, 22	ALERT POLARITY	ACTIVE HI TRIGGER (5 TO 28 VDC)	ACTIVE LOW TRIGGER (GROUND)
23, 24	RESERVED	DO NOT TOUCH	MUST BE OFF
25	COPILOT CONTROL HEAD INSTALLED	COPILOT CONTROL HEAD IN USE	NO COPILOT CONTROL HEAD
26	OBSVR 1 CONTROL HEAD INSTALLED	OBSERVER 1 CONTROL HEAD IN USE	NO OBSERVER CONTROL HEAD
27	OBSVR 2 CONTROL HEAD INSTALLED	OBSERVER 2 CONTROL HEAD IN USE	NO OBSERVER 2 CONTROL HEAD
28	REVERSIONARY MODE SEE §2.7.4.1	USER STATIONS "REVERT" TO OTHER CONTROL HEADS WHEN FAILED	USER STATIONS IN FAILSAFE WHEN FAILED
29	TRANSMIT MUTE	COM RECEIVE AUDIO MUTES FOR ALL HEADSETS TRANSMITTING WHEN ANY TX PTT IS PRESSED. COM TX IS STILL HEARD (PREVENTS SQUEALING ON CLOSE FREQS)	SELECTED COM AUDIO IS HEARD DURING TRANSMIT
30	STUCK MIC ENABLE	IGNORES PTT IF GROUNDED FOR MORE THAN 35 SEC.	NO STUCK MIC TIMEOUT
31	MICROPHONE SENSITIVITY	REDUCED MIC SENSITIVITY FOR LOUD COCKPITS	NORMAL MIC SENSITIVITY
32	PASSENGER 1, 2 OR CREW OXYGEN MIC	P453-15 BECOMES PILOT O ₂ MIC P453-16 BECOMES COPILOT O ₂ MIC	P453-15 BECOMES PASS 1 MIC P453-16 BECOMES PASS 2 MIC
33	PASSENGER 1, 2 OR OBSERVER OXYGEN MIC	P453-17 BECOMES OBSVR 1 O ₂ MIC P453-18 BECOMES OBSVR 2 O ₂ MIC	P453-17 BECOMES PASS 3 MIC P453-18 BECOMES PASS 4 MIC

PS Engineering
PAC45L Audio Selector Panel and Intercom System
Installation and Operator's Manual

SWITCH NUMBER	FUNCTION	ON	OFF
34	COM 7 & COM 8 AUDIO OR COM 1 & COM 2 SIDETONE	J452-33 IS COM 1 SIDETONE INPUT J452-34 IS COM 2 SIDETONE	J452-33 IS COM 7 AUDIO INPUT J452-34 IS COM 8 AUDIO INPUT
35	PA SIDETONE	SIDETONE FROM EXTERNAL PA IS ACTIVE	LOCAL SIDETONE FOR EXTERNAL PA
36	UNSWITCHED 1 & 2 SPLIT	UNSWITCHED #1 IS NOT PROVIDED TO COPILOT UNSWITCHED #2 IS NOT PROVIDED TO PILOT	UNSWITCHED #1 AND 2 PROVIDED TO BOTH CREWMEMBERS
37	UNSWITCHED TO OBSERVER	UNSWITCHED AUDIO PROVIDED TO OBSERVER POSITIONS	NO UNSWITCHED AUDIO AT OBSERVER POSITIONS
38	STEREO OBSERVER	OBSERVER POSITIONS ARE STEREO (LEFT & RIGHT CHANNELS ACTIVE)	OBSERVER POSITIONS ARE MONO (LEFT OUTPUT)
39	STEREO CREW	CREW POSITIONS ARE STEREO (LEFT & RIGHT CHANNELS ACTIVE)	CREW POSITIONS ARE MONO (LEFT OUTPUT)
40	8Ω HEADSETS	AUDIO OUTPUTS COMPATIBLE WITH LOW IMPEDANCE HEADPHONES	AUDIO OUTPUTS COMPATIBLE WITH HIGH IMPEDANCE (150Ω TO 300Ω) HEADPHONES
41	RECEIVER INDICATION	INDICATOR BLINKS WHEN AUDIO SIGNAL IS PRESENT ON A SELECTED RECEIVER	NO RECEIVER INDICATION
42	MUSIC MUTE	MUSIC WILL MUTE WHEN RADIO OR INTERCOM IS ACTIVE	MUSIC MUTES ONLY WHEN RADIO IS ACTIVE
43	COPILOT MUSIC ENABLE	COPILOT POSITION CAN HEAR MUSIC	COPILOT POSITION WILL NEVER HEAR MUSIC
44	OBSERVER 1 MUSIC ENABLE	OBSERVER 1 POSITION CAN HEAR MUSIC	OBSERVER 1 WILL NEVER HEAR MUSIC
45	OBSERVER 2 MUSIC ENABLE	OBSERVER 2 POSITION CAN HEAR MUSIC	OBSERVER 2 WILL NEVER HEAR MUSIC
46	ALERTS ON SPEAKER	AURAL ALERT AUDIO IS PRESENTED ON COCKPIT SPEAKER	AURAL ALERT AUDIO IS NOT PRESENTED ON COCKPIT SPEAKER
47	BACKLIGHT VOLTAGE	ON FOR 28VDC	OFF FOR 14 OR 5 VDC
48	BACKLIGHT VOLTAGE	ON FOR 28 OR 14 VDC	OFF FOR 5 VDC

2.7.4.1 HUB45R Bottom Logic Switches

In the PAC45L System, the DIP switches located on the bottom of the HUB45 is configured from the factory:

Position	1	2	3	4	5	6
Switch						
J7	ON	ON	ON	OFF	OFF	OFF
J8	OFF	OFF	OFF	ON	ON	ON

If it is necessary to check or set these switches, remove the foil covers.



Figure 2-3 - LOGIC SWITCH Locations



Figure 2-4 LOGIC SWITCH LOCATIONS HUB45A

After any necessary adjustments are complete, apply the gold foil covers, rectangular (575-998-0100) and round (575-998-0050). Spare covers are included in the installation kit.



PS Engineering
PAC45L Audio Selector Panel and Intercom System
Installation and Operator's Manual

J7 SWITCH NUMBER	FUNCTION	ON	OFF
1	UNSWITCHED #5	J452-57 IS UNSWITCHED INPUT 5	J452-57 IS HAND MIC INPUT
2	TEL/MIC	P451-58 IS WIRED TEL INPUT	P451-58 IS OBS #1 HAND MIC
3	EXPANSION	J452-26 IS PASS 5 MIC INPUT	J452-26 IS EXPANSION INPUT
4	RESERVED	N/A	DEFAULT
5	RESERVED	N/A	DEFAULT
6	EXPANSION	EXPANSION UNIT IN SYSTEM	NO EXPANSION

NOTE An additional switch must be selected to utilize these Hand Mics. Ensure that Switch 58 is in the up position. [See 2.7.14.](#)

J8 SWITCH NUMBER	FUNCTION	ON	OFF
1	RESERVED	DEFAULT	N/A
2	RESERVED	DEFAULT	N/A
3	COPILOT FAILSAFE	COPILOT HEARS NAV 2	NO FAILSAFE NAV AUDIO
4	PILOT FAILSAFE	PILOT HEARS NAV 1	NO FAILSAFE NAV AUDIO
5	COPILOT FAILSAFE	COPILOT HEARS UNSWITCHED 2	NO FAILSAFE UNSWITCHED AUDIO
6	PILOT FAILSAFE	PILOT HEARS UNSWITCHED 1	NO FAILSAFE UNSWITCHED AUDIO

2.7.4.2 CTL45L DIP switches

The pilot and coplot control heads can accommodate different audio routing if desired.

Push-Pull Volume Switch	Controls Navaid Audio Source	Pilot DIP Sw J7, Position 5	Copilot DIP Sw J7, Position 5
MKR	MKR1 & MKR2 FOR PILOT. MKR1 & MKR2 FOR COPILOT.	OFF	OFF
MKR	MKR1 ONLY FOR PILOT. MKR1 & MKR2 FOR COPILOT.	ON	OFF
MKR	MKR1 & MKR2 FOR PILOT. MKR2 ONLY FOR COPILOT.	OFF	ON
MKR	MKR1 ONLY FOR PILOT. MKR2 ONLY FOR COPILOT.	ON	ON
ADF	ADF1 & ADF2 FOR PILOT. ADF1 & ADF2 FOR COPILOT.	OFF	OFF
ADF	ADF1 ONLY FOR PILOT. ADF1 & ADF2 FOR COPILOT.	ON	OFF
ADF	ADF1 & ADF2 FOR PILOT. ADF2 ONLY FOR COPILOT.	OFF	ON
ADF	ADF1 ONLY FOR PILOT. ADF2 ONLY FOR COPILOT.	ON	ON

After any necessary adjustments are complete, replace the cover and apply the foil covers, rectangular (575-045-0162) and round (575-998-0050). Spare covers are included in the installation kit.



2.7.5 Fail-Safe Audio and Reversionary Mode

HUB power is pin P451-42, if no power is applied to this pin, the HUB45A goes into Failsafe Mode.

While in Failsafe Mode, you must have bus voltage applied to Alert Power pin P451-41 to hear the nine aural alerts, refer to [Section 3.10](#) for more information.

2.7.5.1 Fail-Safe options

When **ON**, Switch 1 allows the crew to have Audio Alerts in Fail-Safe, when the alert subsystem is powered.

Switches 3 provides the option for the pilot and copilot to hear the Audio Alerts in normal operation (Switch 3).

2.7.5.2 Reversionary Mode

When Switch 28 is **ON**, CTL45L Control heads will “revert” to the next higher control head if it is turned off. If the copilot’s control head is switched off (fail-safe), the copilot will hear what the pilot has selected and transmit on the radios the pilot has selected.

If Switch 28 is **OFF**, the user just goes into fail-safe, with no ability to change radios and hears the audio associated with that position.

2.7.6 Microphone settings

2.7.6.1 Transmit Muting

Switch 29 controls the muting of other receivers when one is transmitting. When Switch 29 is **ON**, other receivers are muted during transmission. This can prevent bleed over and squealing if they are operating on close frequencies, or the antennas are close together. However, it prevents other crew members from hearing radios they have selected for receiving during transmissions.

Sidetone from the transmitter is still heard when selected.

2.7.6.2 Stuck Mic Enable

When Switch 30 is **ON** the PAC45L will ignore any push-to-talk input that is held low for more than 35 seconds. This function resets if the PTT ground is released. If Switch 30 is **OFF**, a PTT will key the selected radio indefinitely, and rely on the radio’s internal stuck mic protection.

2.7.6.3 Microphone Sensitivity

If Switch 31 is **ON**, the intercom microphone sensitivity is decreased by 6dB. This makes the intercom more resistant to noisy aircraft environments. PS Engineering recommends trying the PAC45L in normal mode (Switch 31 **OFF**) first, because the IntelliVox® does perform very well in most airplanes and rotorcraft.

2.7.6.4 Oxygen Microphones or Passenger Intercom inputs

P453-15 and P453-16 can be either Passenger 1 and Passenger 2 intercom microphone inputs, or, when Switch **32** is **ON** they will become Pilot and Copilot Oxygen microphone inputs. These are activated when an OXY mode is on.

2.7.7 Artificial Transmit Sidetone

2.7.7.1 COM 1 & COM 2 Sidetone or COM 7 & 8 Audio

Contact PS Engineering for more information.

2.7.7.2 Public Address Sidetone

When Switch 35 is **ON**, the audio input from J452-37 is active when the PTT is pressed in Public Address mode as an input from an external PA Amplifier. When Switch 35 is **OFF**, the PAC45L creates a local sidetone for public address.

2.7.8 Unswitched Audio

2.7.8.1 Splitting Unswitched 1 and 2 between Pilot and Copilot

Unswitched Input #1 (J452-55) and Unswitched #2 (J452-35) can be split between the pilot and copilot, if desired. If Switch 36 is "**ON**" the pilot will hear unswitched 1, and never hear unswitched 2, while the copilot will hear unswitched 2, and never hear unswitched 1.

2.7.9 Headphone Options

2.7.9.1 Stereo or Mono

When Switch 39 is **ON**, the Pilot and Copilot positions will receive stereo audio (P451-35 pilot's left ear, P451-56, Right ear, P451-35 copilot's left ear, P451-57, Right ear).

When Switch 38 is **OFF**, crew positions will receive monaural audio (P451-35 and 36, respectively), which is useful if only monaural headphones will be used.

NOTE: The MultiTalker® Head Related Transfer Function will not function in a mono headset.

2.7.9.2 Low Impedance (8Ω headphones)

When Switch 40 is **ON**, the PAC45L audio output is optimized for a low-impedance headphone output of about 8Ω.

When Switch 40 is **OFF**, the PAC45L audio output is optimized for a standard civil aviation headphone impedance headphone output of about 150-300Ω.

2.7.10 Receive Signal Indicator (RXI)

When Switch 41 is **ON**, the receive indicator of the selected receiver will blink when an audio signal is on that input. This is useful for locating the source of a received signal when many are active.

When Switch 41 is **OFF**, there is no received signal indication.

2.7.11 Music Functions

The PAC45L has several options for music presented to pilot and crew.

Regardless of the position of Switches 43, 44, or 45, the Pilot will always hear music, if present, and Switch 42 controls the muting behavior.

2.7.11.1 Music Mute

When Switch 42 is **ON**, any music playing will mute when intercom or radio communication is active.

When Switch 42 is **OFF**, the music will NOT mute when **intercom** audio is present. It will mute for any **radio** activity.

Front panel muting control (long press VOC) will allow music to play uninterrupted during intercom and radio activity.

2.7.11.2 Copilot Music Enable

When Switch 43 is **ON**, the copilot position will hear music that is present

When Switch 43 is **OFF**, the copilot position will never hear music in the system.

2.7.12 Speaker Alert Audio

When Switch 46 is **ON**, the internal audio alert audio messages will be presented to the cockpit speaker.

When Switch 46 is **OFF**, the internal audio alert audio messages never be heard over the cockpit speaker.

2.7.13 Backlight Dimmer Voltage

Switches 47 and 48 control the backlight dimming input expected for the purpose of adjusting the curve.

For 28 VDC backlighting both Switches 47 and 48 are **ON**.

For 14 VDC backlighting, Switch 47 is **OFF** and 48 is **ON**.

For 5 VDC backlighting, both Switches 47 and 48 are **OFF**

2.7.14 Other Shared Functions

Some functions are set by switches not easily accessible to the installer. Contact PS Engineering for detailed information.

These include:

- Hand Mic enable for Copilot (J452-57) eliminate Unswitched 5 input.
- TX-I: Keeps intercom active during radio transmissions so in-aircraft conversations can continue when a crew member is communicating out of the aircraft.
- Artificial Sidetone feature so whomever is transmitting can still hear themselves and other headsets will hear if they are selected/receiving the same transceiver.

These switches are accessible by removing the side plate of the HUB45A using the following procedure:

NOTE: THIS PROCESS SHALL ONLY BE PERFORMED IN A CLIMATE AND FOD CONTROLLED ENVIRONMENT, BY AN AUTHORIZED PS ENGINEERING INSTALLER.

1. Remove qty. 6 #440 c 3/16" Countersunk screws (p/n 4754422001) from side with DIP switches.

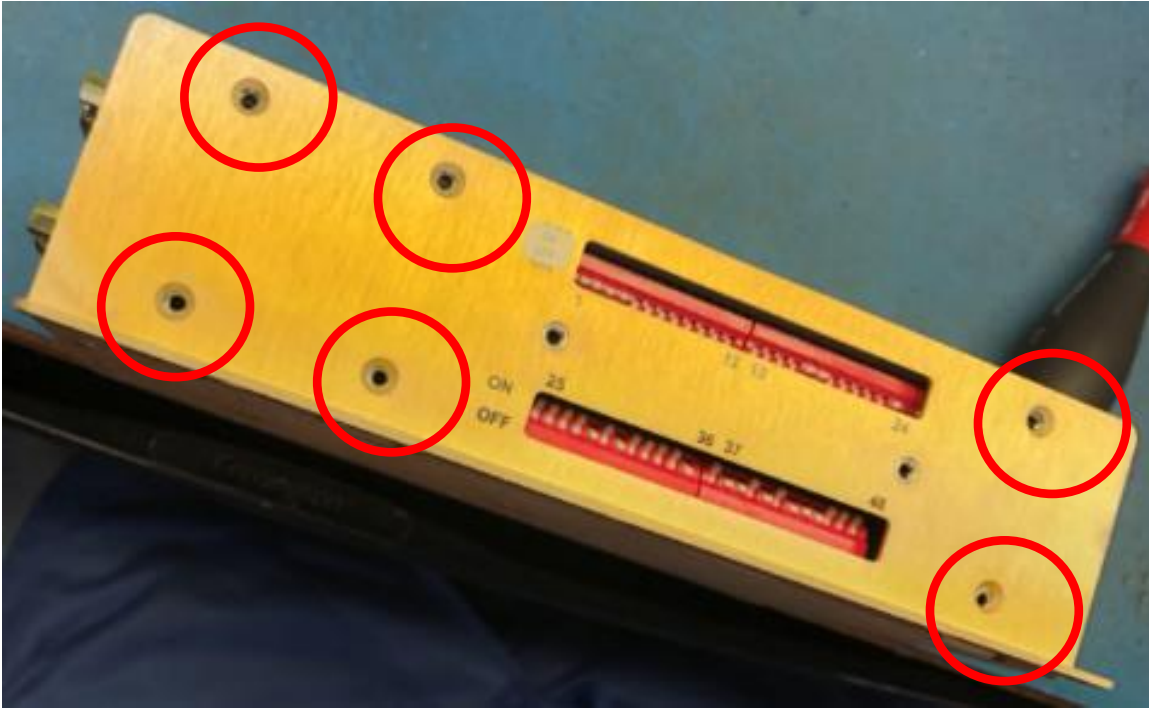

2. Remove side panel to expose additional DIP switches.

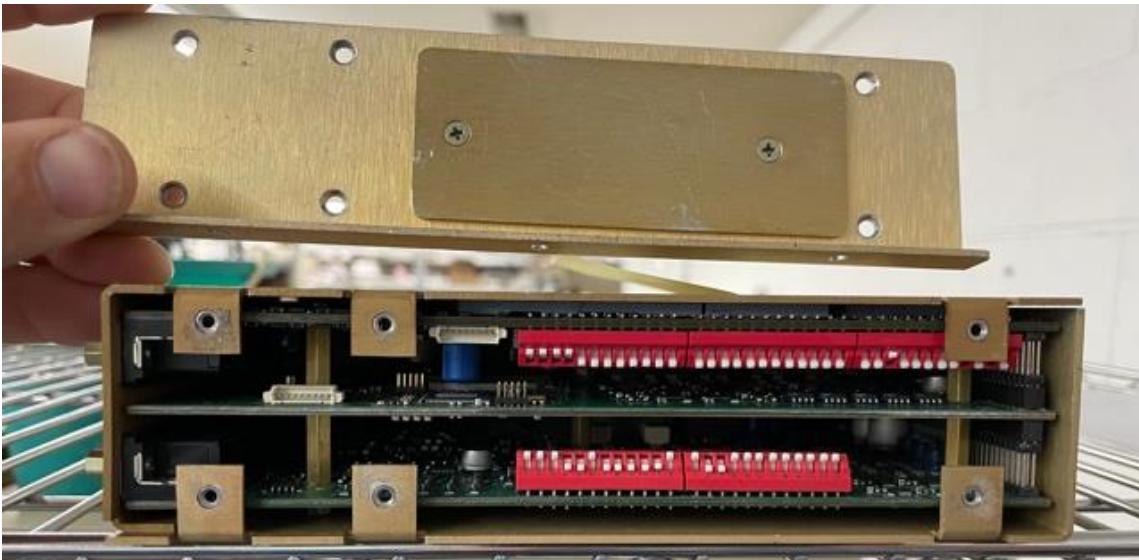

3. Identify additional DIP switch bank



4. Select options as needed.



PS Engineering
PAC45L Audio Selector Panel and Intercom System
Installation and Operator's Manual

SWITCH NUMBER	FUNCTION	ON (UP)	OFF (DOWN)
		BOLD IS FACTORY DEFAULT	
49	ALERTS ENABLE	UP (ON) AUDIO ALERTS ENABLED	AUDIO ALERTS DISABLED
50	RECORD AUDIO ALERTS	RECORD AUDIO	NO AUDIO RECORDING
51	BT ENABLE	BLUETOOTH MODULE ENABLED	NO BLUETOOTH FUNCTIONS
52	PASS 4 = CREW 3	PASSENGER 4	3 RD CREW POSITION
53	J45239: OBS1 CVR <i>OR</i> OBS1 SPR	OBS1 CVR ON J45239	OBSERVER 1 SPEAKER ON J45239
54	J45240: OBS2 CVR <i>OR</i> COPILOT SPR	OBSERVER 2 CVR OUTPUT ON J45240	COPILOT SPEAKER OUTPUT ON J45240
55	ARTIFICIAL COM RADIO SIDETONE	ARTIFICIAL SIDETONE PRODUCED	SIDETONE OFF (SIDETONE FROM RADIO)
56	PSE EXPANSION INSTALLED	EXPANSION ENABLED	EXPANSION DISABLED
57	HUB DB9 J455 = OBS2 CTL45A <i>OR</i> PILOT CTL45A	OBSERVER #2 CTL45A CONNECTED TO J455	PILOT CTL45A CONNECTED TO J455
58	HAND MIC ENABLE FOR COPILOT & OBS1 <i>OR</i> SWAP MODE	HAND MIC ACTIVE	COM SWAP MODE ENABLED
59	TXI ENABLE	INTERCOM ACTIVE DURING RADIO PTT	INTERCOM MUTED DURING PTT
60	RESERVED	DO NOT TOUCH	DEFAULT POSITION

5. After settings are confirmed, reinstall the side plate by reversing the disassembly procedure.
6. Test and verify all changed settings.
7. Perform an installed system test in accordance with Section 2.10.

PS Engineering
PAC45L Audio Selector Panel and Intercom System
Installation and Operator's Manual

2.8 PAC45L Pin assignments

P451		J452	
Pin	Description	Pin	Description
1	Ground	1	Lighting Common
2	Ground	2	Music Ground
3	Ground	3	Ground
4	Ground	4	Ground
5	Ground	5	Ground
6	Ground	6	Ground
7	Ground	7	Ground
8	Ground	8	Ground
9	Ground	9	Ground
10	Ground	10	Ground
11	Ground	11	Ground
12	Ground	12	Ground
13	Ground	13	Ground
14	Ground	14	Ground
15	Ground	15	Ground
16	Ground	16	Ground
17	Ground	17	Ground
18	Ground	18	Ground
19	Ground	19	Ground
20	Aircraft Ground	20	Speaker Ground
21	Aircraft Ground	21	PA Ground
22	Pilot Hand Mic	22	Lighting In
23	Pilot Mic	23	Music Left
24	Copilot Mic	24	Expansion Power Out
25	No Connect	25	Expansion Out
26	No Connect	26	Passenger 5 or Expansion Mic
27	COM1 Mic [1]	27	COM1 Audio [1]
28	COM2 Mic [2]	28	COM2 Audio Hi [2]
29	COM3 Mic [3]	29	COM3 Audio Hi [3]
30	No Connection	30	No Connection
31	No Connection	31	No Connection
32	No Connection	32	No Connection
33	No Connection	33	COM1 Sidetone
34	No Connection	34	COM2 Sidetone
35	Pilot Left/Mono Headset	35	UNSW2
36	Copilot Left/Mono Headset	36	UNSW4
37	No Connection	37	PA Sidetone
38	Passenger 1, Mono Headset	38	Telephone Out
39	Passenger 2,3 Left/Mono Headset	39	No Connect
40	Passenger 4,5 Left/Mono Headset	40	Copilot Speaker Output
41	Alert Power	41	Speaker Pilot
42	Aircraft Power	42	PA Out
43	Pilot Hand TX PTT	43	Music Right
44	Pilot TX PTT	44	Radio Mute
45	Copilot TX PTT	45	Pilot ICS
46	No Connect	46	Call
47	No Connect	47	NAV1 (AUX1) Audio Hi [4]
48	COM1 Key [1]	48	NAV2 (AUX2) Audio Hi [5]
49	COM2 Key [2]	49	ADF 1 (AUX3) Audio Hi [6]
50	COM3 Key [3]	50	ADF 2 (AUX4) Audio Hi [6]
51	No Connection	51	MKR 1 (AUX5) Audio Hi [7]
52	No Connection	52	MKR 2 (AUX6) Audio Hi [7]
53	No Connection	53	DME 1 (AUX7) Audio Hi [8]
54	No Connection	54	DME 2 (AUX8) Audio Hi [9]
55	No Connection	55	UNSW1
56	Pilot Right Headset	56	UNSW3
57	Copilot Right Headset	57	UNSW5 or Copilot Hand Mic Audio Hi
58	No Connection	58	Tel Mic In
59	Passenger 1, Passenger 4 Right Headset	59	Telephone Key
60	Passenger 2,5 Right Headset	60	CVR Pilot
61	Passenger 3,6 Right Headset	61	CVR Copilot
62	O ₂ Mic Failsafe Power	62	PA Key

Numbers in brackets [1] indicate the associated front panel bezel location. See Appendix B Radio Wiring.

PS Engineering
PAC45L Audio Selector Panel and Intercom System
Installation and Operator's Manual

P453		J454	
Pin	Description	Pin	Description
1	Ground	1	TX- Pilot
2	Ground	2	TX+ Pilot
3	Ground	3	RX- Pilot
4	Ground	4	RX+ Pilot
5	Ground	5	Ground
6	Ground	6	Ground
7	Ground	7	Ground
8	Ground	8	Ground
9	Ground	9	Ground
10	Alert 1	10	No Connect
11	Alert 2	11	No Connect
12	Alert 3	12	No Connect
13	Alert 4	13	No Connect
14	Alert 5	14	Passenger 5 ICS PTT
15	Passenger 1 Mic Hi or pilot O ₂ Mic	15	Passenger 4 ICS PTT
16	Passenger 2 Mic Hi or Copilot O ₂ Mic	16	Passenger 3 ICS PTT
17	Passenger 3 Mic	17	Passenger 2 ICS PTT
18	Passenger 4 Mic	18	Passenger 1 ICS PTT
19	Alert 6	19	TX- Copilot
20	Alert 7	20	TX+ Copilot
21	Alert 8	21	RX- Copilot
22	Alert 9	22	RX+ Copilot
23	Alert Ack and message programming	23	No Connect
24	No Connect	24	No Connect
25	Pilot Com Swap	25	Copilot ICS PTT
26	Oxygen Mask Enable	26	Pilot ICS PTT

J455 (HUB45AR)		P455 (CTL45L)	
Pin	Description	Pin	Description
1	RX-	1	TX-
2	RX+	2	TX+
3	TX-	3	RX-
4	TX+	4	RX+
5	Ground	5	Common
6	No Connect	6	No Connect
7	CTL Power out	7	Aircraft Power
8	Aircraft Ground	8	Aircraft Ground
9	Open	9	Open

See §2.7 for shared functions (OR)

Table 2-3: PAC45L Pin Assignments

2.9 Wiring Checkout

After wiring is complete, verify power is ONLY on pins 41, 42 & 62 of J451 and airframe ground on pins 20 & 21. Failure to do so will cause serious internal damage and void PS Engineering's warranty.

CAUTION: Do not connect or disconnect (HOT SWAP) any components with power applied, this will damage the units

2.10 Operational Checkout

2.10.1 Required Test Equipment

In order to return an aircraft to service after installation of the PAC45L, the installer must have access to headset(s) and be able to establish 2-way communications on appropriate radios.

Equivalent test equipment is acceptable as long as the testing requirements can be met.

Due to the configurable nature of the PAC45L, control head nomenclature may differ than illustrations.

Some PAC45L systems are intended for integration with other manufacturer's EFIS. Contact system integrator for operation details.

2.10.2 Audio controller Test

NOTE

The *IntelliVox*® is designed for ambient noise levels of 80 dB or above. Therefore, some clipping may occur in a quiet cabin, such as without the engine running, in a hangar. This is normal.

1. Apply power to the aircraft and avionics.
2. Verify fail-safe operation by receiving and transmitting on COM 1 from the pilot position, with the audio controller power off /EMG mode (XMT Selector fully CW).
3. Switch on the unit by turning the XMT select knob to the full CCW position (COM 1).
4. Verify that the COM 1 legend in both the XMT and RCV change to green. Verify that transmit **indicator is not flashing green**. . . If the LED is flashing green, stop testing and troubleshoot the microphone PTT installation. If for any reason the transmit PTTs are stuck, then they will disconnect after 35 seconds.
5. Verify proper transmit and receive operation from the pilot position, noting that the copilot PTT switch allows proper transmission on the selected transceiver. Verify that the Selected XMIT legend flashes green when transmitting.
6. Rotate the XMT knob to the COM 2 transceiver position and verify the indicators change to track the selection, and COM 2 receiver is heard.
7. Repeat for any other installed communications radios (up to 8 total).
8. Verify proper operation of all receiver sources (NAV 1, NAV 2, and AUX 3 through 8) by selecting them by pulling the appropriate knob to the out position. Turn the knob and verify that the audio level changes.
 - NOTE: Navaid selection is as follows:
 - MKR 2 controlled via MKR knob, Switch Position 6.
 - ADF 2 controlled via ADF knob, Switch Position 7.
9. With several sources selected, verify that the volume level of the radios in the headset is controlled by the INNER concentric knob.
10. If configured for Oxygen mask mics, activate the remote OXY switch; verify that the microphone audio source is the Oxygen Masks.
11. Verify proper crew Intercom system operation in the **ALL**, **ISO** and **CREW** modes.
12. With the intercom in ISO mode, activate the CALL switch request from passenger stations, and observe that the CALL light illuminates, and a chime is heard in crew headset.
 - Verify that switching the intercom into ALL mode on either crew control head will cancel the CALL function.
13. Verify that the volume level of the intercom is controlled by the inner concentric volume knob.
14. Verify that the audio selector panel system does not adversely affect any other aircraft system by systematically switching the unit on and off, while monitoring the other avionics and electrical equipment on the aircraft.
15. Repeat for the other aircraft crew stations.

2.10.3 Bluetooth Checkout

Verify that the PAC45L will “pair” with a Bluetooth device, and interface with cellular phone and Music source. See [§ 3.7.2](#) for more information.

If PAC45L is not connecting, resetting the Bluetooth memory might be required. Hold down HRTF & ICS buttons for 3 seconds until there is a chime in pilot headset.

2.10.3.1 Bluetooth TEL Checkout

Pair the PAC45L with a Bluetooth telephone device. Verify that the pilot headset is connected to the cellular telephone system (if installed). The telephone function will allow any person heard by the pilot on the intercom, also heard on the telephone.

To make or receive a phone call, you must pull the TEL knob on the audio controller panel.

2.11 Final Inspection

Verify that the wiring is bundled away from all controls and no part of the installation interferes with aircraft control operation. Move all controls through their full range while examining the installation to see that no mechanical interference exists. Verify that the cables are secured to the aircraft structure in accordance with good practices, with adequate strain relief. Ensure that there are no kinks or sharp bends in the cables and coaxial cables. Verify that the cables are not exposed to any sharp edges or rough surfaces, and that all contact points are protected from abrasion.

Complete documentation that may be required, such as a logbook entry, weight and balance computation and FAA Form 337. Sample text for FAA Form 337, and instructions for continuing airworthiness can be found in Appendix F. Return completed warranty registration application to PS Engineering, or complete online at www.ps-engineering.com.

Section III OPERATION

3.1 SCOPE

This section provides basic operating instructions for the PS Engineering PAC45L, Audio Selector Panel/Intercom Systems. Please read it carefully before using the equipment so that you can take full advantage of its capabilities.

Note: Because of the flexibility to customize the PAC45L systems nomenclature, the appearance and naming conventions may differ from those shown below.

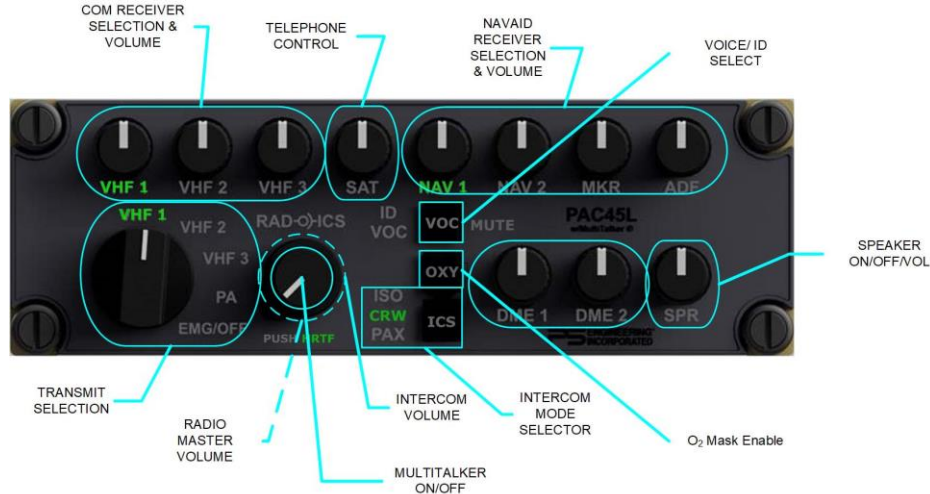

Figure 3-1 PAC45L Typical Operating Controls

3.2 Power and Fail Safe

Unit power is controlled by the transmitter (XMT) rotary selector knob. In the "EMG" or OFF (fully clockwise) position, the pilot headset is connected directly to COM 1 as well as alerts and unswitched input #1. This allows communication capability regardless of unit condition.

The power controls all audio selector panel functions, and intercom.

3.2.1 Fail Safe Audio Distribution

Here is the audio present for each station in Fail Safe:

Station	Audio Present in Fail Safe		
Pilot – Left ear (tip)	COM 1	NAV 1 ^[1]	Unswitched 1*
Pilot Right ear (ring)	Alert Audio ^[2]		
Copilot – Left ear (tip)	COM 1 ^[1]	NAV 2 ^[1]	Unswitched 2
Copilot– Right ear (ring)	Alert Audio ^[2]		
Observer– Right ear (ring)	Alert Audio ^[3]		
^[1] Configured by J8 switch	^[2] Configured by SW1	^[3] Configured by SW2	

3.3 Communications Transmit (XMT) Selection

The PAC45L has a rotary control knob to select communications transceiver functions. To select a transceiver for transmit; turn the knob to select the desired radio from the eight available.

The radio is automatically selected to receive incoming radio calls when the XMT is selected. With a PAC45L, you will *never* transmit on a radio that you are not receiving. The selected audio is indicated by both knob position and the green text.

Pilot Com Swap (P453 pin 25) switch is available to select next transmit comm without removing your hands from the yoke. Like going from COM1 to COM2. Turning the transmit selector switch will remove the swap mode.

3.4 COM Audio Selector

The communications receiver audio sources are controlled by a combination pull-on-push-off switch/volume control. Communication audio from another radio, not selected for transmit, can be heard by pulling the associated RCV switch, which will place it in the OUT position. The selected audio is indicated by both knob position and the green nomenclature text.

The Radio Master Control Volume (small inner knob labeled RAD) should always be at MAX volume.

The volume controls for the individual radios are the normal way of changing respective radio volumes. The RAD volume control is to allow an easy way to reduce all radio volumes temporarily to assist in intercommunications (intercom).

You will always hear the audio from the selected transceiver; even if the selected com audio is turned all the way down on the audio controller because it cannot turn off the selected receive audio all the way.

The volume of the received source is adjusted by rotating the knob.

3.4.1 Multi-Talker™ Head Related Transfer Function (HRTF)

Communication receiver audio signals are presented to the DSP and processed to “appear” in a different location to the crew. “MultiTalker” (US Patent #7,391,877) specifies up to nine locations. This helps the crew to better comprehend speech by locating it in a manner more easily differentiated by the human brain.

Intercom and other audio are not spatially processed, only the three communications transceivers.

NOTE: You must use stereo headsets, in stereo mode for this feature.

This adjustment allows the eight Spatial Audio inputs to be “relocated” on any of nine (9) pre-defined “Head Related Transfer Function” (HTRF) locations.

MultiTalker® places the communications receiver audio in one of nine apparent locations in the crew’s headset. This has been scientifically shown to allow the brain to focus on multiple conversations and improve comprehension for the listener.

3.4.2 HRTF On /Off

Activating the HRTF toggles the PAC45L MultiTalker® spatial function in a stereo headset, (receiver sources distributed) or off (receiver audio sources neutral). Each user with a control head will have HRTF activation capability.



HRTF **REQUIRES** Stereo Headsets. If monaural headsets are used, the received audio will sound “distant” or somewhat distorted.

3.4.3 Audio Location

The pilot controller can adjust the locations for the three receive audio locations. Press and hold the OXY front panel rubber button for > 1 second on the pilot’s panel until all COM nomenclature start blinking green.

Rotate the COM receive volume knobs so the pointer indicates the approximate location of the desired location. A voice announcement will accompany the knob rotation with the clock positions. Received audio shall then be presented from that location. Repeat for other communication radios as desired.

Press the OXY button again to exit the mode. The audio controller will remember last state through power cycles. The locations set by the pilot CTL45L

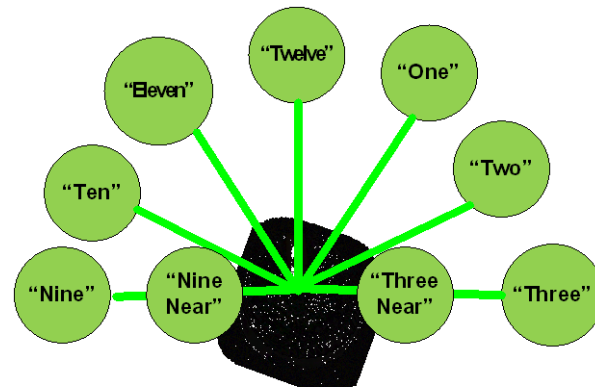

are the same for all users.

Figure 3-2 Spatial Audio Locations and Voice Annunciations

NOTE: **IF** the HUB45AR is *configured* for Mono operation (SW39- Crew OFF) the HRTF function will **not** work, and the HRTF button will not turn green.

3.4.4 Monitor Mode (CTL45L J7, switch 4)

If HRTF feature is not desired, then the CTL45L can be configured so Monitor Mode is active. Monitor mode allows all offside comms to be active until the transmit comm audio is active. This is a nice feature that allows you to not be disturbed by the audio of another comm.

Pushing the HRTF switch will activate monitor mode.

3.5 Navaid Selection

Navigation receivers are selected in the same manner as the communication receiver, pull on/push off the knob associated with the desired navigational aid, and rotate to adjust the receiver volume.

If equipped, Marker 2 will be heard when the MKR is selected, and ADF 2 will be heard if ADF is selected.

3.5.1 Ident Filter

The PAC45L System is equipped with an identifier filter that will enhance the 1030 Hz Morse Code identifier (ID Mode), or reduce the Morse Code identifier for clearer reception of voice transmissions or VOR (VOC).

The ident filter is added to Nav 1, NAV 2 and ADF inputs.



3.6 OXY (P453-26 and front panel OXY)

Activates the Oxygen Mask microphone inputs if configured.

3.7 Intercom Operation (8)

3.7.1 IntelliVox® Intercom VOX-Squelch

No adjustment of the *IntelliVox*® squelch control is necessary. Through individual signal processors, the ambient noise appearing in all microphones is constantly being sampled. Non-voice signals are blocked. When someone speaks, only their microphone circuit opens, placing their voice on the intercom.

The system is designed to block continuous tones; therefore, people humming or whistling in monotone may be blocked after a few moments.

For consistent performance, any headset microphone **must** be placed within ¼-inch of your lips, preferably against them. (ref: *RTCA/DO-214, 1.3.1.1 (a)*).

NOTE

It is also a good idea to keep the microphone out of a direct wind path. Moving your head through a vent air stream may cause the *IntelliVox*® to open momentarily. This is normal.

The *IntelliVox*® is designed to work with normal aircraft cabin noise levels (70 dB and above). It loves airplane noise! Therefore, it may not recognize speech and clip syllables in a quiet cabin, such as in the hangar, or without the engine running. This is normal.

3.7.2 Intercom Volume Control

The outer concentric volume control knob adjusts the loudness of the intercom for the intercom station(s) connected to the audio controller panel. It has no effect on selected radio levels, or music input levels.

3.7.3 Intercom Modes- front panel ICS button

The “ICS” pushbutton switch on the panel provides the selection of the intercom modes

The intercom mode defaults to “CRW” at power up. Then the ICS button toggles between CRW & ISO. A green indicator shows which mode is currently active.

ISO: Each control head has their own ISOLATE selection. The control head is isolated from the intercom stations and is connected only to the aircraft radio's that are selected system. They will hear the aircraft radio reception (and sidetone during radio transmissions).

CRW: Pilot and copilot are connected on one intercom channel and have exclusive access to the aircraft radios. The pilot or copilot control head will decide when the system will be in the ALL mode by pressing their ICS switch.

PAX: Pilot and copilot have the option to add passengers to their intercom channel by holding down the ICS button for 4 seconds. This will then all passengers to speak with that crew station. Cycling power will place system back into the Crew mode and no passengers.



3.8 Speaker operation

To activate the cockpit speaker, pull the SPR knob out and adjust the volume as desired. This will place all received audio over the cockpit speaker. Both pilot & copilot have their own separate cockpit speaker selection.

3.9 Bluetooth® connection

The PAC45L has an internal Bluetooth module (FCC ID: QQQWT32i), no external boxes required, but external antenna will be required. The audio controller is always “discoverable,” so you just need to search for the PAC45 from your Bluetooth-equipped phone or music source. Default access code is not required. Once the PAC45 has been “paired” with your Bluetooth device, the TEL distribution will act as described in § [3.7.2](#).

3.9.1 Pairing and unpairing Bluetooth devices

The PAC45L can be paired with up to eight individual devices but will only connect to one at a time. When that number is exceeded, the PAC45L will drop a device to allow the new device to be added.

Once paired, the audio controller should connect automatically.

Hint, if your devices are not recognized by the PAC45L, you may need to cycle Bluetooth on or off from your device. If that does not help, you may need to reset the Bluetooth module, Press, and hold VOC and ICS switches for more than three (>3) seconds. Then “forget” the audio controller from your device, and re-pair.

3.9.2 Bluetooth® Telephone (SAT) Mode

The PAC45L serves as a full duplex interface for telephone systems such as portable cellular phones with Bluetooth connectivity.

Warning:

United States FCC Regulations contained in 47 CFR § 22.925 currently contain prohibition on airborne operation of cellular telephones. “Cellular telephones installed in or carried aboard airplanes, balloons or any other type of aircraft must not be operated while such aircraft are airborne (not touching the ground). When any aircraft leaves the ground, all cellular telephones on board that aircraft must be turned off.”

Answering or placing a call is done from the mobile phone. Once connected, the audio is routed through the headset(s) by pulling the SAT knob out. This knob also adjusts the volume of the telephone audio.

For a [single](#) CTL45L installation:

In **PAX** intercom mode, all crew and passengers will be heard on the phone when they speak.

In **CREW** mode, the pilot and copilot are connected to the telephone.

In **ISO** intercom mode, when the PAC45L is in the **TEL** mode, the pilot position is in the "Phone Booth." Only the pilot will hear the telephone, and only he will be heard.

For multiple CTL45L installation:

Each users CTL45L controls their access to the (SAT switch) telephone audio.

NOTE

PS Engineering does not guarantee compatibility with all personal cellular telephones.

3.9.2.1 Bluetooth Reset

To reset the Bluetooth module, clearing out the connected devices, press VOC and ICS buttons for more than three seconds.



3.9.3 Music Muting Control

The PAC45L incorporates PS Engineering's trademark "SoftMute." The SoftMute™ circuit will mute the music whenever there is conversation on the radio or the intercom. When that conversation stops, the music returns to the previous level comfortably, over a second or so.



Holding down VOC button for three (3) seconds will turn the music muting on/off. There is no LED or light indication only the music will mute or not mute during intercom and radio activity.

When in mute off mode, the intercom, radio & PTT will not mute the music. The music muting will reset to mute on mode at each power cycle. Any control head will switch the muting on or off for *all* users.

3.10 Wired Satcom/Cell Phone input

The PAC45L can accommodate a wired telephone input as well as a Bluetooth connection. This operates the same as the Bluetooth Telephone ([see §3.7.2](#))

3.11 Aural Alert Audio

The PAC45L incorporates an independent alert audio system that can store nine audio messages recorded by the user and played back when triggered by an external source.

Once triggered, the alert audio will continue until the ACK button (front panel or external) on the CTL45L control panel is pushed, or the trigger input returns to normal. Edge-triggered alerts will play 3 times or until ACK is pushed, whichever occur first.

The PAC45L system can store three audio alerts, default audio is stored at the factory. These are "Master Caution," "Alert," a simple chime, 1000 Hz tone, Doorbell Chime, Ring Tone, "Timer at Zero," "Intercom Call," and " Check Engine Instruments."

In Failsafe Mode, Alert audio is on the RING (Right channel) of the headsets. If mono headsets are being used, then left ear & right ear wiring must be tied together to hear aural alerts.

3.11.1 Storing Alert Audio

The PAC45L systems can store nine audio alerts. You must record **all nine** when the unit is in audio program mode. You cannot change *only one at a time*. If you wish to replace just one message, we recommend you write down all the messages before starting the procedure. To record and use the Alert function, a remote Acknowledge (ACK, P453-23) button must be installed.

NOTE:

THESE MESSAGES ARE STRICTLY SUPPLEMENTAL AND OPTIONAL, AND SHALL NOT REPLACE ANY EXISTING ALERTS IN THE AIRCRAFT. IT IS THE INSTALLERS' RESPONSIBILITY TO DETERMINE IF THIS ALTERATION IS MAJOR OR MINOR AND PROVIDE APPROPRIATE DOCUMENTATION (FORM 337, SUPPLEMENTS, ETC.)

To record messages from the pilot's headset:

1. Press & Hold "remote acknowledge button" (P453-23 to ground) until a chime is heard in the headset, and then *release* the button.
2. COM1 will blink, to indicate the recording of ALERT #1.
3. Start speaking message.
4. When finished with Alert #1, press the button again.
5. Now COM2 will blink, to indicate the recording of ALERT #2.
6. Speak message.
7. When finished with Alert #2, press the "button"
8. Repeat for messages #3 to #9
9. A chime indicates that recording is now finished.

NOTE: If the acknowledge button is not pressed to indicate end of recording, it will record for five seconds, and then advance to next alert. After all time slots are timed out, the PAC45L will exit the alert recording mode.

Section IV – Warranty and Service

4.1 Warranty

In order for the factory warranty to be valid, the installations in a certified aircraft must be accomplished by an FAA- (or other ICAO agency) certified avionics shop and authorized PS Engineering dealer. If the unit is being installed by a non-certified individual in an experimental aircraft, a factory-made intercom harness must be used for the warranty to be valid.

PS Engineering, Inc. warrants this product to be free from defect in material and workmanship for a period of two (2) years from the date of sale. During the first **twelve (12) months** of the two-year warranty period, PS Engineering, Inc., at its option, will send a replacement unit at our expense if the unit should be determined to be defective after consultation with a factory technician. For the remaining **twelve (12) months** of the two-year warranty period, PS Engineering, Inc., at its option, will send a similar replacement unit at the customers' expense if the unit should be determined to be defective after consultation with an authorized PS Engineering dealer.

All transportation charges for returning the defective units are the responsibility of the purchaser. All domestic transportation charges for returning the exchange or repaired unit to the purchaser will be borne by PS Engineering, Inc. The risk of loss or damage to the product is borne by the party making the shipment, unless the purchaser requests a specific method of shipment. In this case, the purchaser assumes the risk of loss.

This warranty is not transferable. Any implied warranties expire at the expiration date of this warranty. PS Engineering SHALL NOT BE LIABLE FOR INCIDENTAL OR CONSEQUENTIAL DAMAGES. This warranty does not cover a defect that has resulted from improper handling, storage or preservation, or unreasonable use or maintenance as determined by us. This warranty is void if there is any attempt to disassemble this product without factory authorization. This warranty gives you specific legal rights, and you may also have other rights, which may vary from state to state. Some states do not allow the exclusion of limitation of incidental or consequential damages, so the above limitation or exclusions may not apply to you.

All items repaired or replaced under this warranty are warranted for the remainder of the original warranty period. PS Engineering, Inc. reserves the rights to make modifications or improvements to the product without obligation to perform like modifications or improvements to previously manufactured products.

4.2 Factory Service

The units are covered by a two-year limited warranty. See warranty information. Call PS Engineering, Inc. at (865) 988-9800 before you return any unit. This will allow the service technician to provide any other suggestions for identifying the problem and recommend possible solutions.

After discussing the problem with the technician and you obtain a Return Authorization number, ship product to:

PS Engineering, Inc.
Attn: Service Department
9800 Martel Rd
Lenoir City, TN 37772
(865) 988-9800 FAX (865) 988-6619
Email: support@ps-engineering.com

Units that arrive without an RMA number, or telephone number for a responsible contact, will be returned un-repaired. PS Engineering is not responsible for items sent via US Mail.

Appendix A – PAC45L Installation Drawings

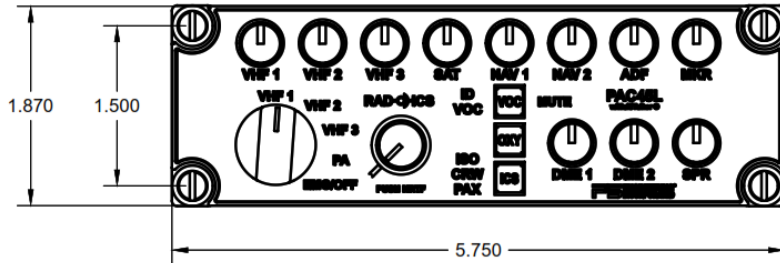

Figure 5-1 - CTL45L Front View

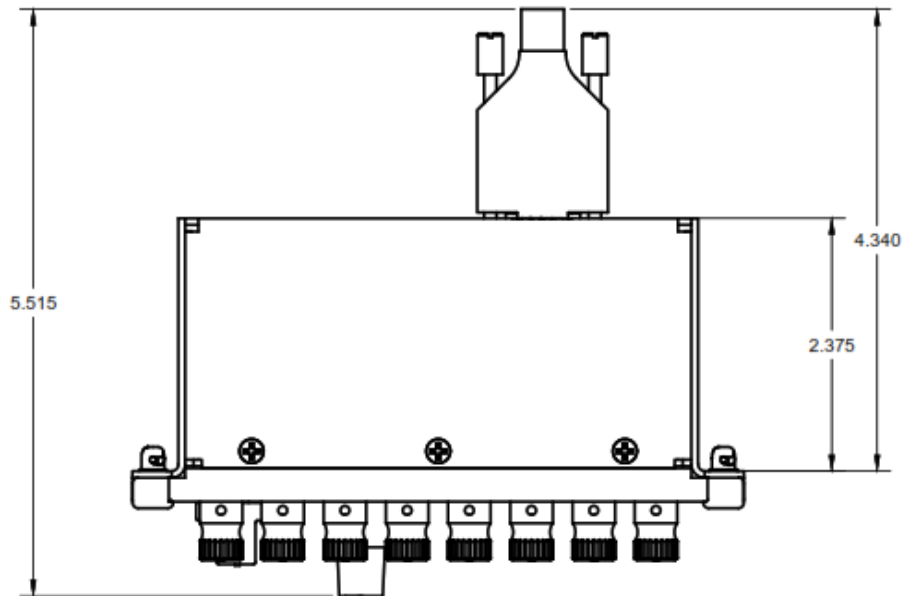

Figure 5-2 CTL45L Top View

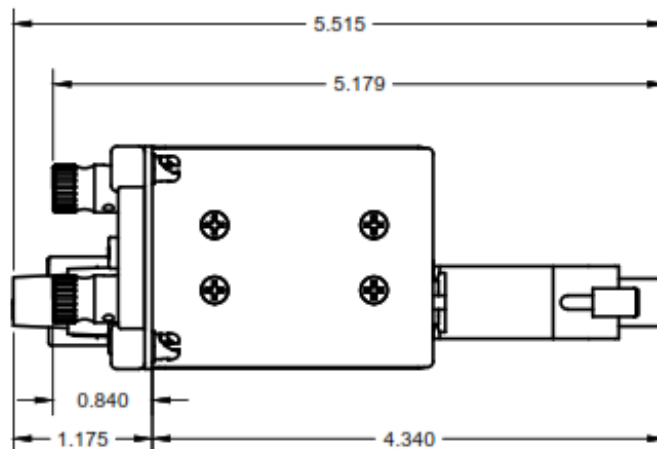

Figure 5-3 CTL45L Side View

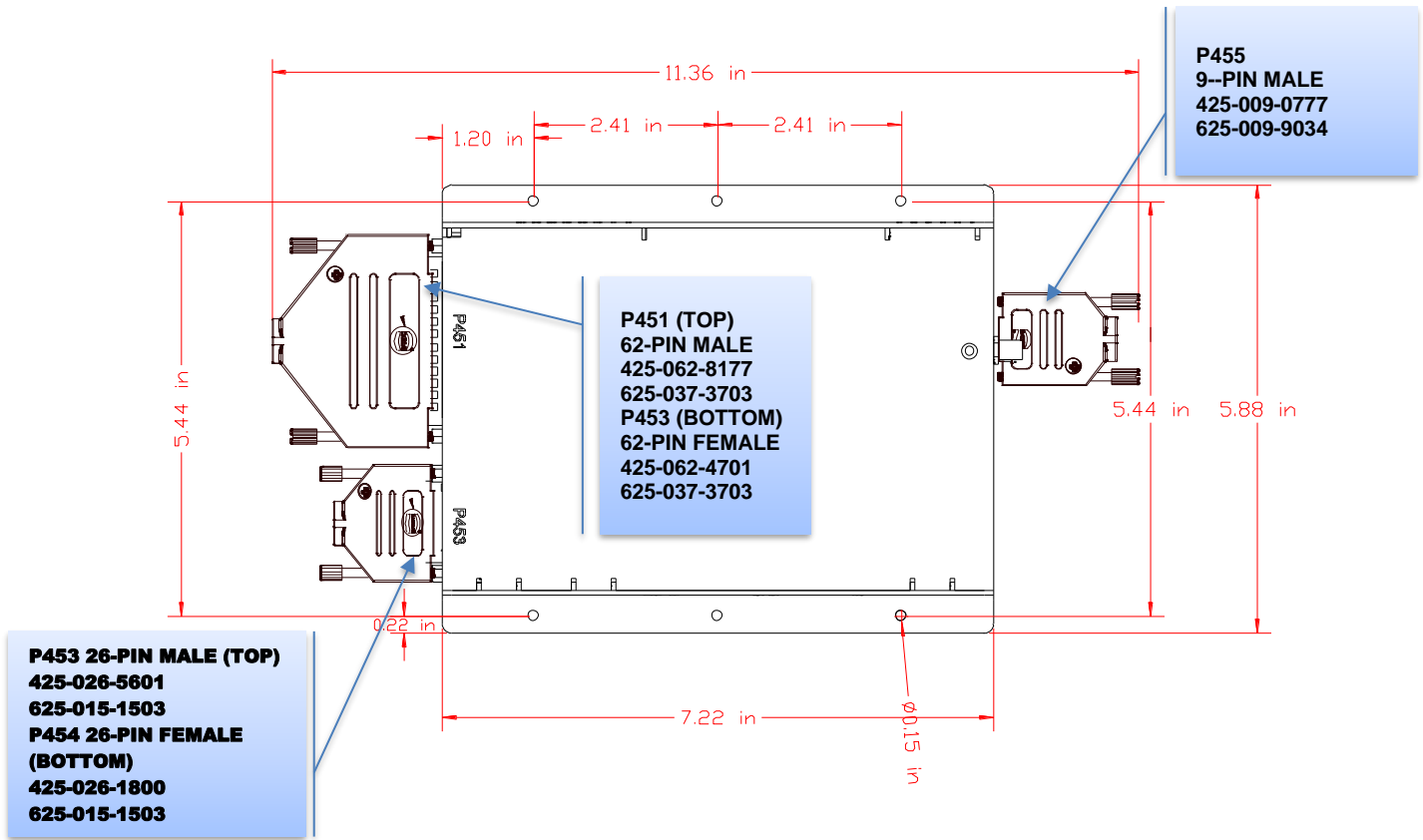

Figure 5-4 - HUB45AR Top View

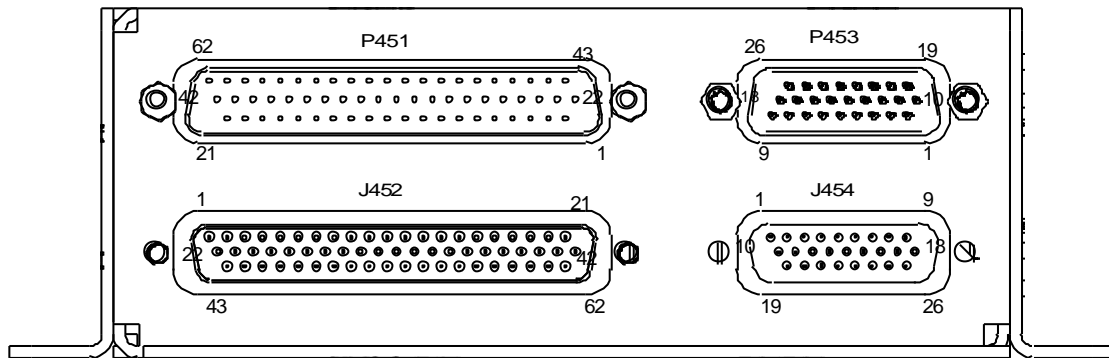

Figure 5-5 - HUB45AR Rear Connector View

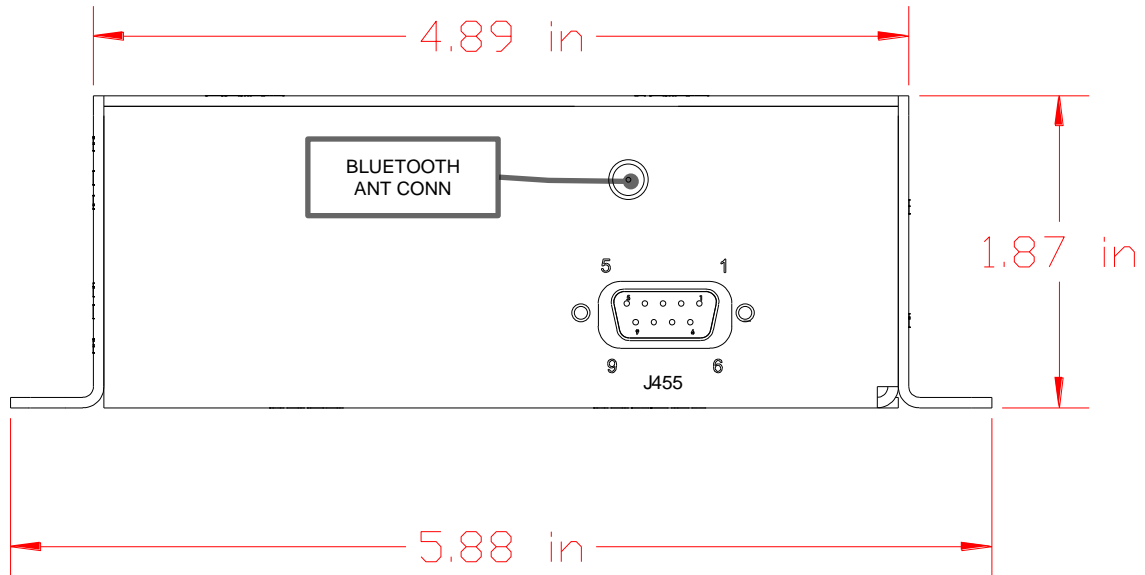

Figure 5-6 HUB4A5R Front View

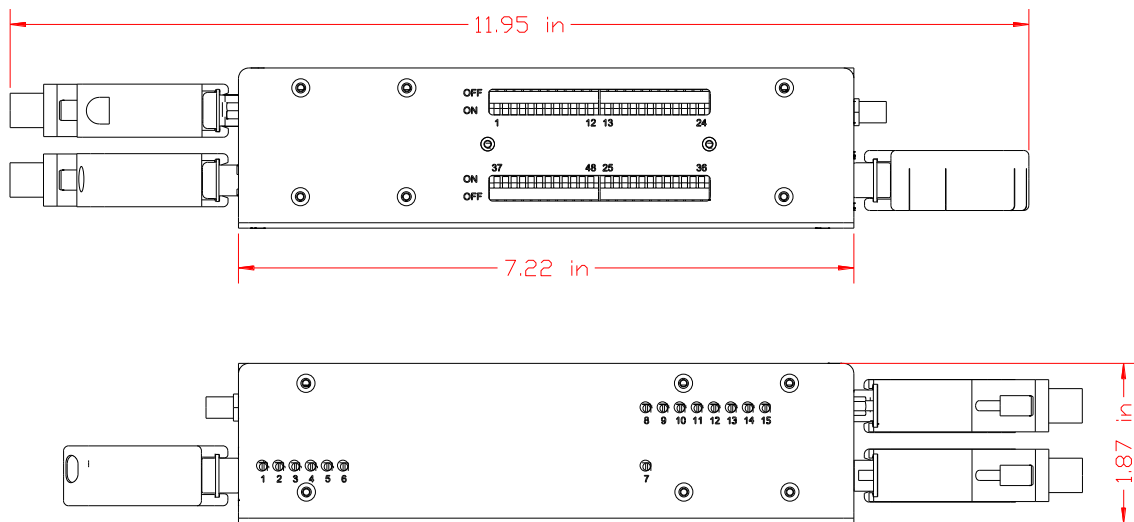

Figure 5-7 - HUB45AR Side Views

Appendix B – Radio Interconnect Wiring

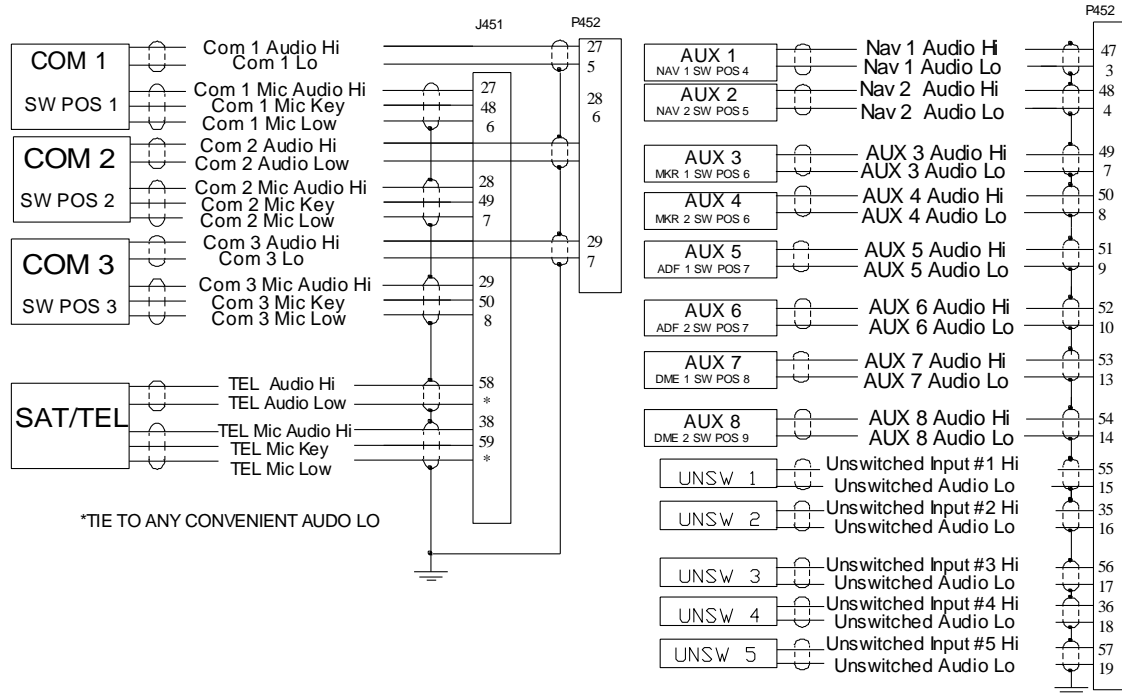
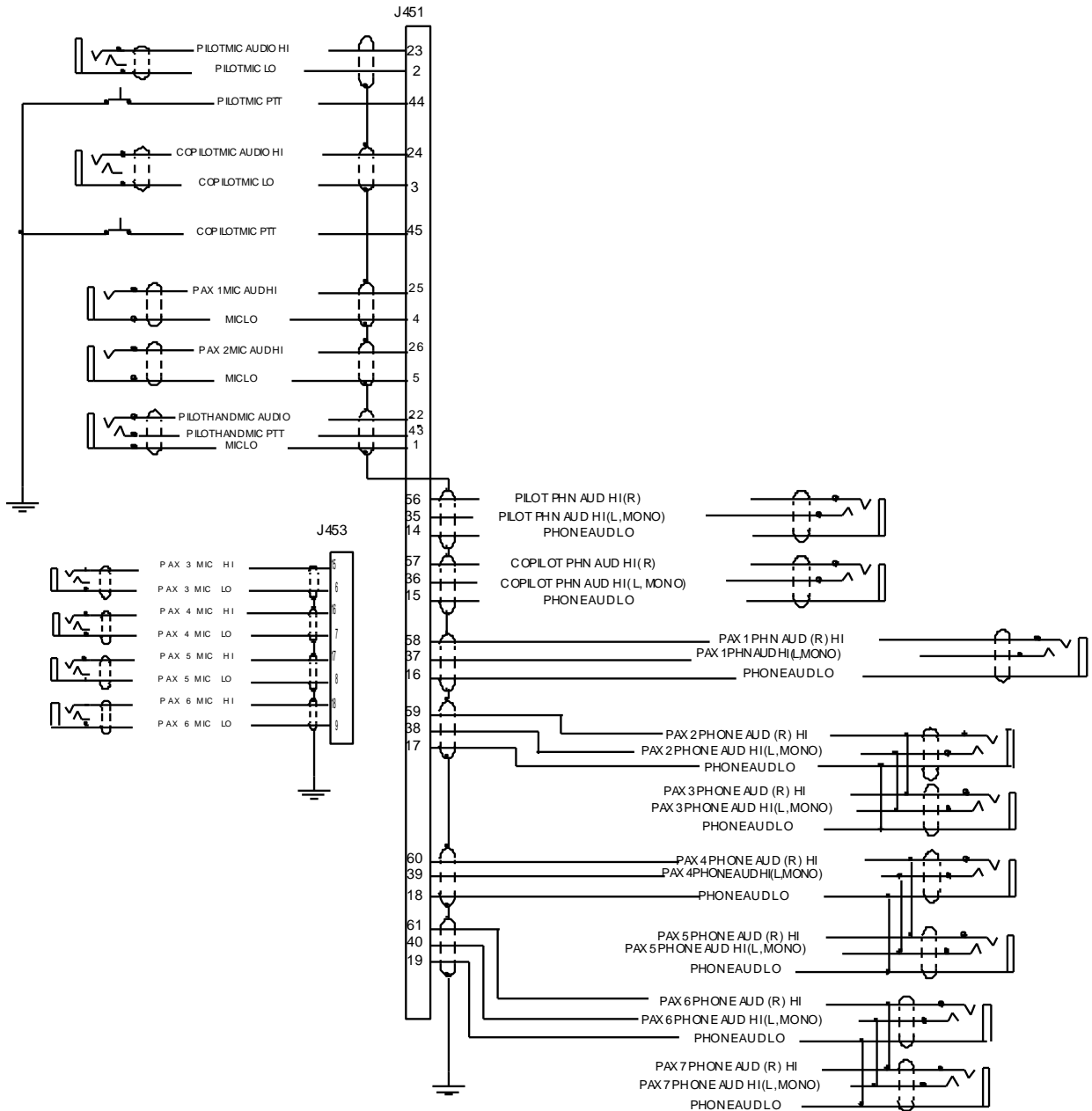

Figure 6-1 Switch Positions

Because of the labeling flexibility on the PAC45L System, the nomenclature on the CTL45 may not match the wiring diagram. Shown here are the switch positions for each of the available inputs.

Appendix C – Intercom Interconnect Wiring



Appendix D – Control Head Interconnect Wiring

PAC45L
 HUB45AR LRU

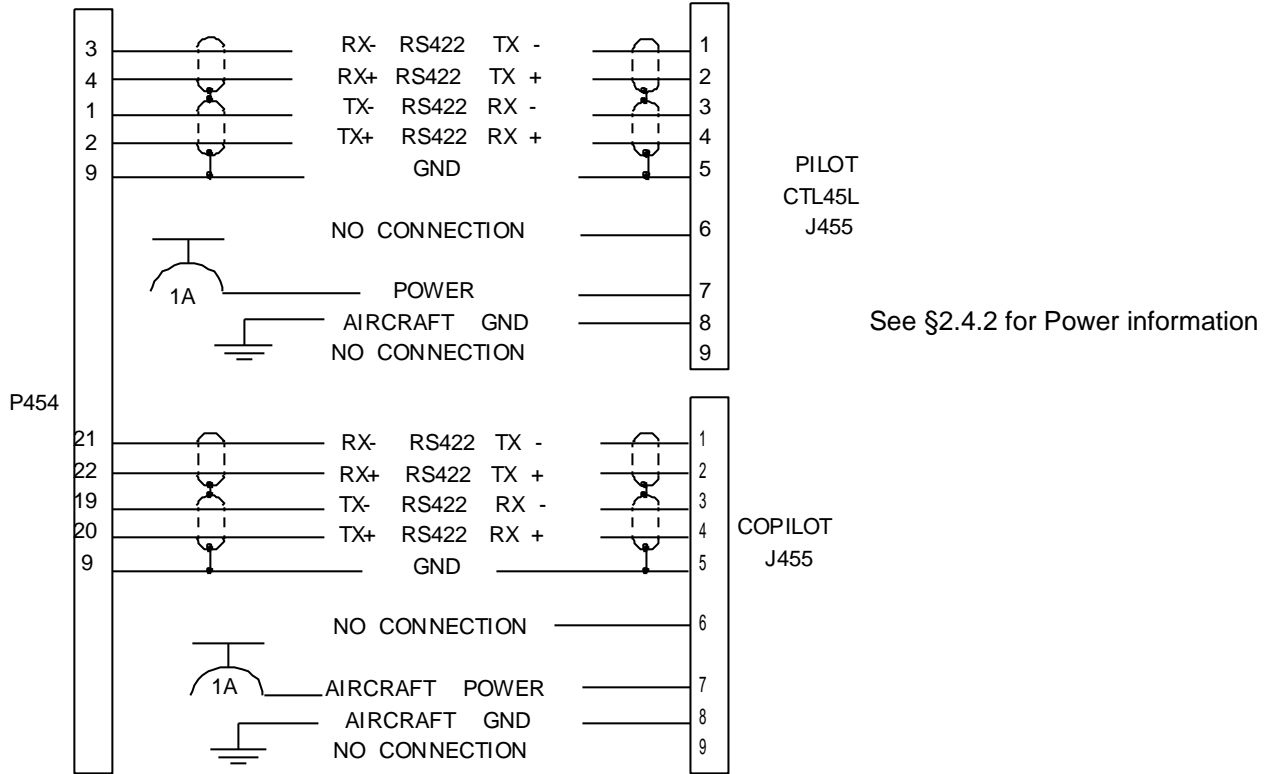

Appendix E, Unit Connector Wiring Reference

9.1 J451 Connections

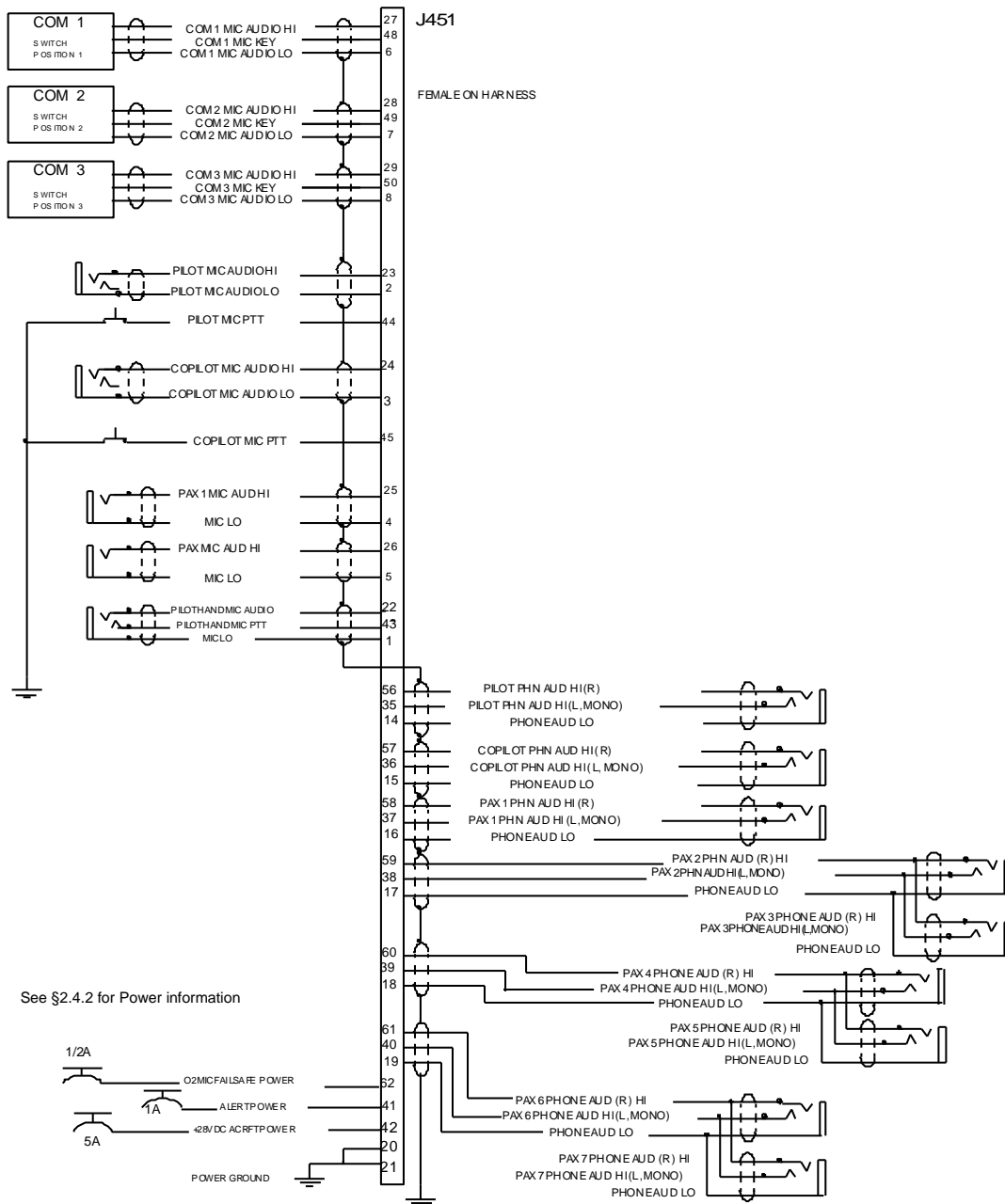

9.2 J452 Connections

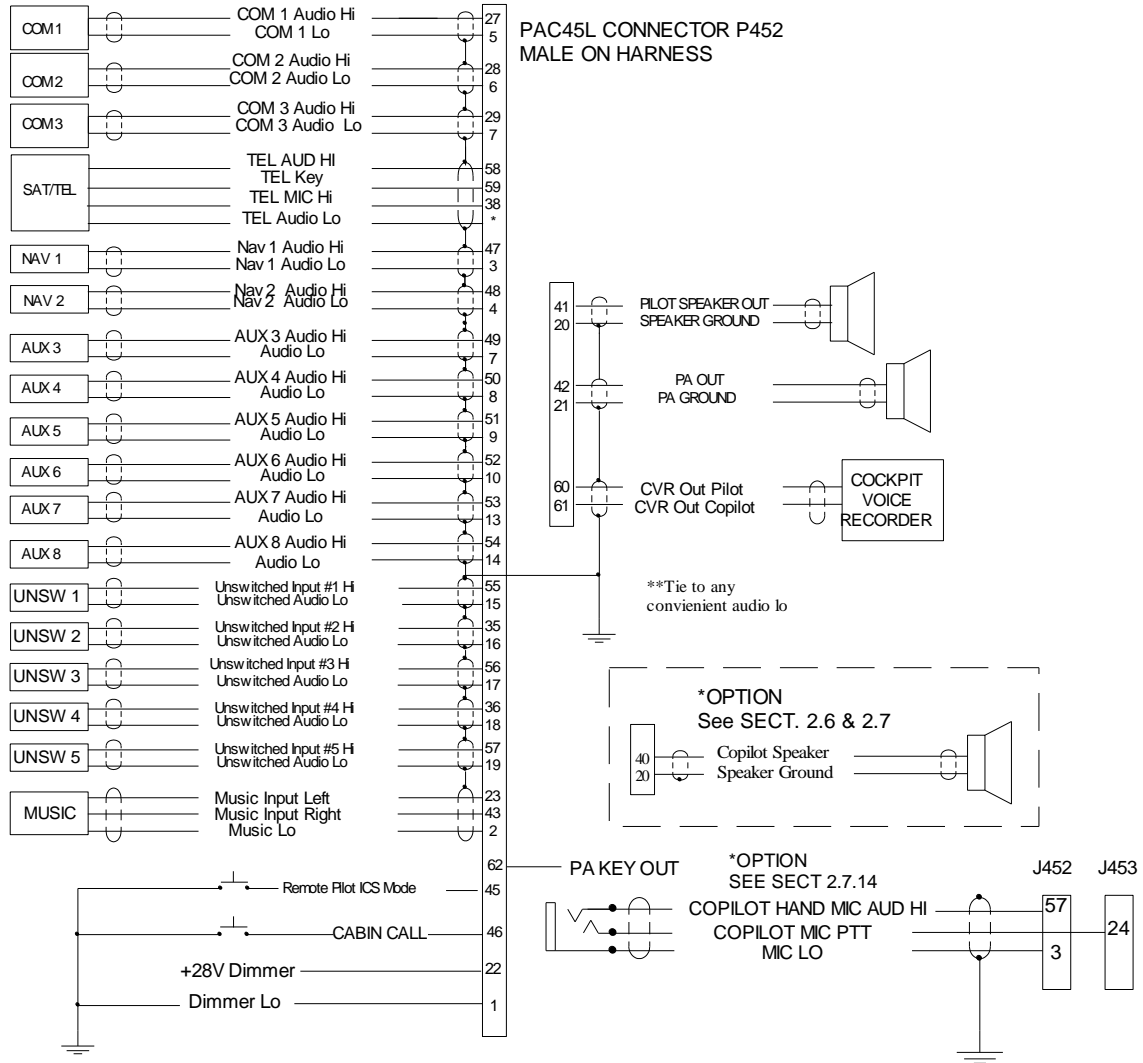

9.3 J453 Connections

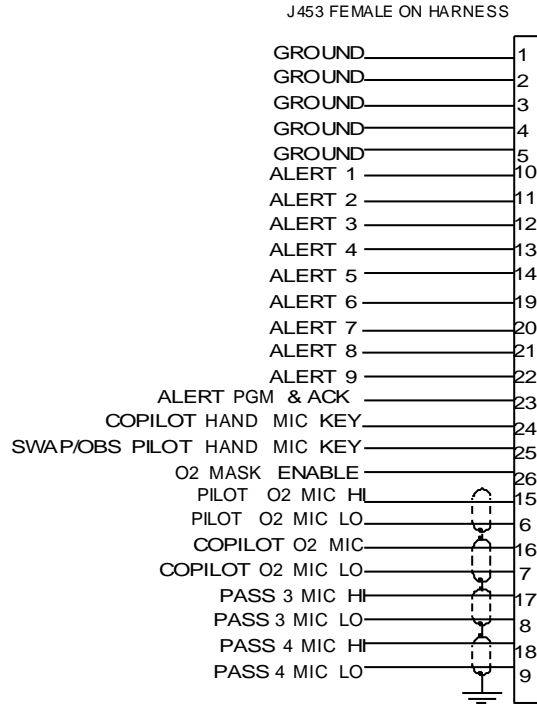

9.4 J454 Connections

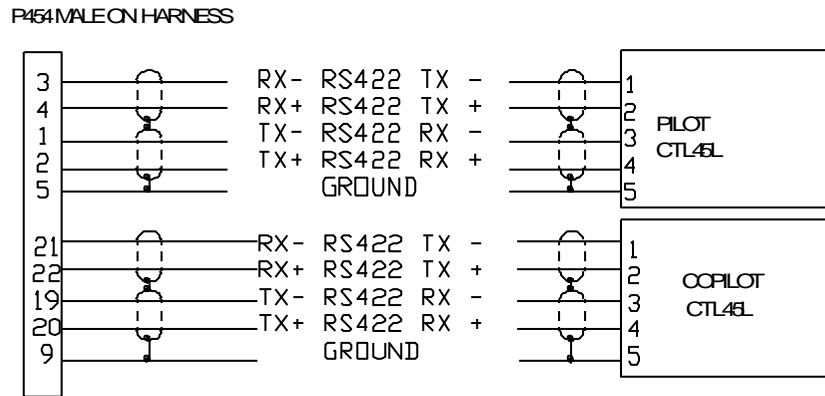

Appendix F – Instructions for FAA Form 337 and continuing airworthiness

10.1 Instructions for FAA Form 337, Audio controllers

One method of airworthiness approval is through an FAA Form 337, *Major Repair and Alteration (Airframe, Powerplant, Propeller, or Appliance)* In the case of the PAC45L, you may use the following text as a guide.

Installed audio selector and 6-place intercom, PS Engineering PAC45L, part number 050-045-(XXXX) in (location) at station . Installed per *AC43.13-2, Chapter 2, paragraph 23* (Instrument Panel Mounting). Installed per PS Engineering *Installation Operators Manual* p/n 200-045-(XXXX), revision (), dated ().

These units are FAA-Approved under TSO C139A for audio amplifiers, and meets environmental qualifications outlined in RTCA DO-160G as appropriate or this aircraft.

Interface to existing aircraft radios in accordance with installation manual and in compliance with practices listed in *AC43.13-2, Chapter 2*. All wires are Mil-Spec 22759 or 27500. Connection to aircraft dimmer bus is . Power is supplied to the unit through a 3A circuit breaker (type and part number), and total electrical load does not exceed % of the electrical system capacity with the PAC45L added.

Aircraft equipment list, weights and balance amended. Compass compensation checked. A copy of the operation instructions, contained in PS Engineering document 202-045-(XXXX), revision (), dated (), is placed in the aircraft records. All work accomplished listed on Work Order .

Appendix G – RTCA DO160G Environmental Qualification Form

11.1 Model Number PAC45L Audio Selector Panel/Intercom Remote Hub

Part Number: 050-045-()

FAA TSO Number: C139a,

Manufacturer: PS Engineering Incorporated 9800 Martel Road Lenoir City TN 37772

Conditions	Section	Conducted Tests
Temperature and Altitude	4.0	Equipment tested to CAT D2
Low Temperature	4.5.1	-45°C Low Operating
	4.5.2	-55° C Survival,
	4.5.4	-45°C Low Short-Term Operating
High Temperature	4.6.1	+85°C Survival,
	4.6.2	+55°C High Operating
	4.6.3	+70°C High Short Time Operating
In-flight Loss of Cooling		Not Applicable, no cooling required
Altitude		50,000' unpressurized (D2)
Decompression		Not Applicable
Overpressure		Not Applicable
Temperature variation	5.2	Equipment tested to Category B
Humidity	6.0	Equipment tested to Category A
Shock	7.0	Equipment tested to Category B Standard operational shock and crash safety
Vibration	8.0	Equipment tested to Category SM, SB, U2FF1, Helicopter Random
Explosion	9.0	Category X, not tested
Waterproofness	10.0	Category X, not tested
Fluids Susceptibility	11.0	Category X, not tested
Sand and Dust	12.0	Category X, not tested
Fungus	13.0	Category X, not tested
Salt Spray	14.0	Category X, not tested
Magnetic Effect	15.0	Equipment tested to Category Z
Power input	16.0	Equipment tested to Category Z (28V)
Voltage Spike	17.0	Equipment tested to Category A (600V)
Audio Frequency Susceptibility	18.0	Equipment tested to Category Z
Induced Frequency Susceptibility	19.0	Equipment tested to Category ZC
Radio Frequency Susceptibility	20.0	Equipment tested to Category T
Radio Frequency Emission	21.0	Equipment tested to Category B
Lightning Induced Transient Susceptibility	22.0	Equipment tested to Category A3J33
Lightning Direct Effects	23.0	Category X, not tested
Icing	24.0	Category X, not tested
ESD	25.0	Category A

11.2 Instructions for Continuing Airworthiness, Audio System

Sample ICA Checklist for PS Engineering PAC45L Audio System:

Section	Item	Information
1	Introduction	Installation of audio control panel with intercommunications system, with integrated audio alert system.
2	Description	Installation as described in manufacturer's installation manual referenced on installation documentation (FAA Form 337, etc.), including interface with other avionics audio as required.
3	Controls	See installation and operator's guide referenced on installation documentation.
4	Servicing	None Required
5	Maintenance Instructions	On Condition, no special instructions
6	Troubleshooting	In the event of a unit problem, place the unit into "off," "fail-safe" and/or "emergency" mode. This allows pilot communications using COM 1, and unswitched audio for critical alerts, copilot communications on VHF. Follow checkout instructions in the installation manual referenced on the FAA Form 337. For a specific unit fault, contact the manufacturer at (865) 988-9800 for special instructions.
7	Removal and replacement information	<u>Removal:</u> The CTL45L is attached to the aircraft using ¼-turn Dzus fasteners. To release, insert a slotted screwdriver into the head and turn counterclockwise. Release the wiring connectors by sliding the latches from the retaining standoff. The HUB45AR is attached to the aircraft using four #6 screws on the flanges. <u>Installation:</u> Reverse the connector installation process. Place the unit against the Dzus rail and with the slotted screwdriver push gently and turn ¼-turn to secure.
8	Diagrams	Not applicable
9	Special Inspection Requirements	Not Applicable
10	Protective Treatments	Not Applicable
11	Structural Data	Not Applicable
12	Special Tools	None
13	Not Applicable	Not Applicable
14	Recommended Overhaul Periods	None
15	Airworthiness Limitations	Not Applicable
16	Revision	To be determined by installer

11.3 Model Number CTL45L, Audio Selector Control Panel

Part Number: 050-045-(20, -40XX)

FAA TSO Number: C139a

Manufacturer: PS Engineering Incorporated 9800 Martel Road Lenoir City TN 37772

Conditions	Section	Conducted Tests
Temperature and Altitude	4.0	Equipment tested to CAT D1
Low Temperature	4.5.1	-20°C Low Operating
	4.5.2	-55° C Survival,
	4.5.4	-40°C Low Short-Term Operating
High Temperature	4.6.1	+85°C Survival,
	4.6.2	+55°C High Operating
	4.6.3	+70°C High Short Time Operating
In-flight Loss of Cooling		Not Applicable, no cooling required
Altitude		50,000' unpressurized (D2)
Decompression		Not Applicable
Overpressure		Not Applicable
Temperature variation	5.2	Equipment tested to Category B
Humidity	6.0	Equipment tested to Category B (Severe)
Shock	7.0	Equipment tested to Category B Standard operational shock and crash safety
Vibration	8.0	Equipment tested to SM, SB, U2FF1, Helicopter Random
Explosion	9.0	Category X, not tested
Waterproofness	10.0	Category X, not tested
Fluids Susceptibility	11.0	Category X, not tested
Sand and Dust	12.0	Category X, not tested
Fungus	13.0	Category X, not tested
Salt Spray	14.0	Category X, not tested
Magnetic Effect	15.0	Equipment tested to Category Z
Power input	16.0	Equipment tested to Category Z (28V)
Voltage Spike	17.0	Equipment tested to Category A (600V)
Audio Frequency Susceptibility	18.0	Equipment tested to Category Z
Induced Frequency Susceptibility	19.0	Equipment tested to Category ZC
Radio Frequency Susceptibility	20.0	Equipment tested to Category T
Radio Frequency Emission	21.0	Equipment tested to Category B
Lightning Induced Transient Susceptibility	22.0	Equipment tested to Category A3J33
Lightning Direct Effects	23.0	Category X, not tested
Icing	24.0	Category X, not tested
ESD	25.0	Category A